

ORIGAMI MONO

YOSHIMASA TSURUTA

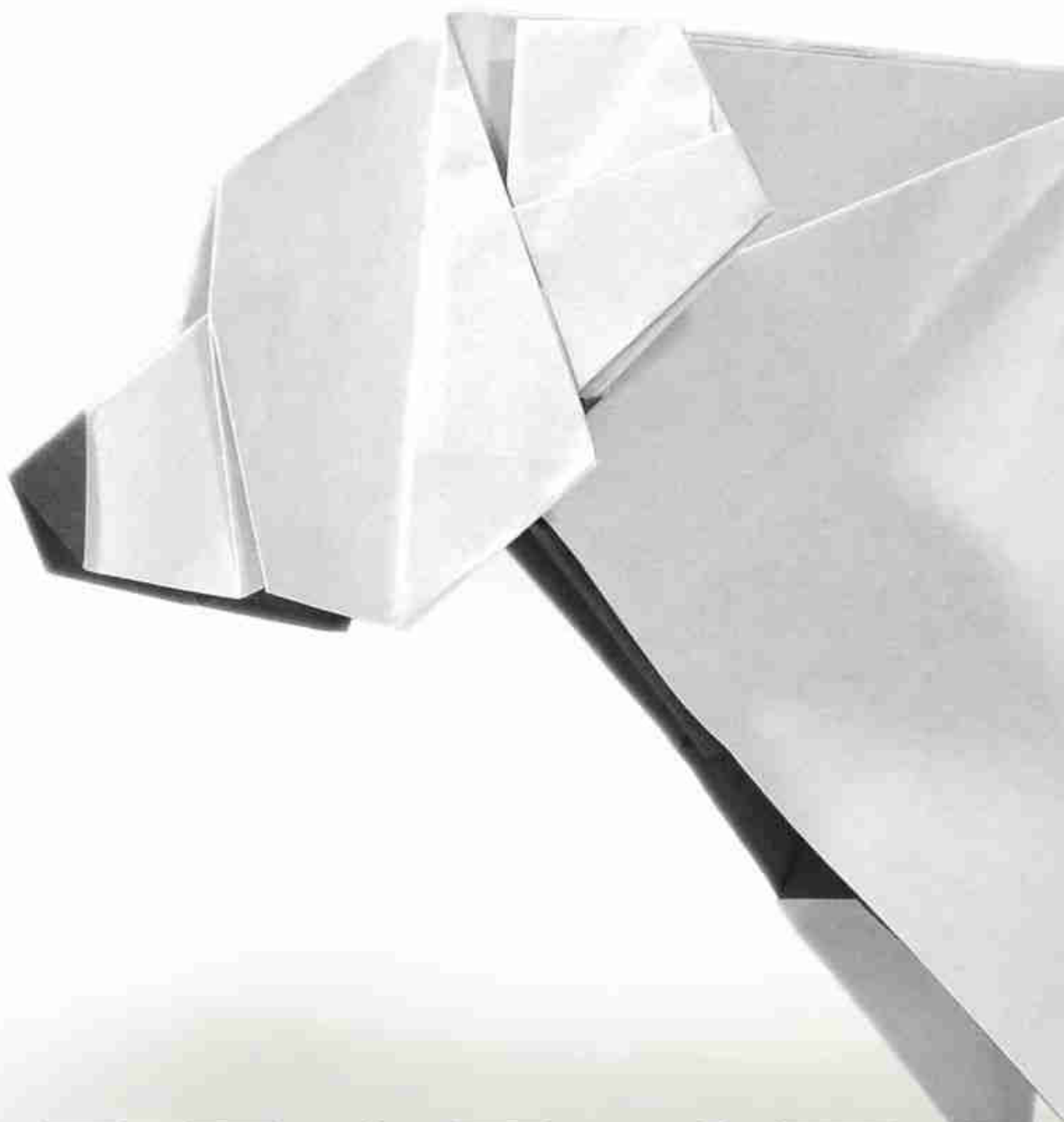

ORIGAMI MONO

YOSHIMASA TSURUTA

黒の乗り手
BLACK RIDER ▶ P. 172

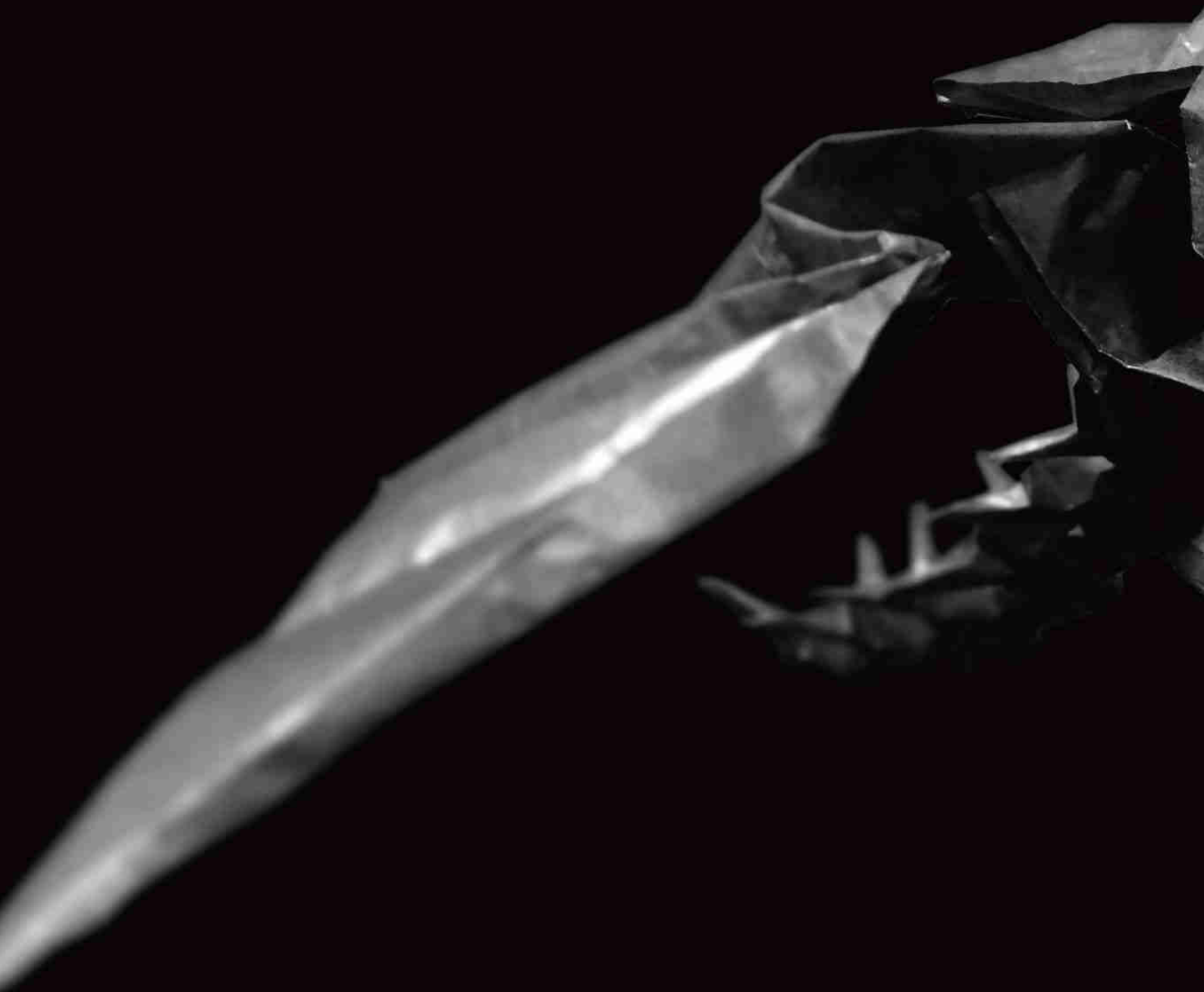



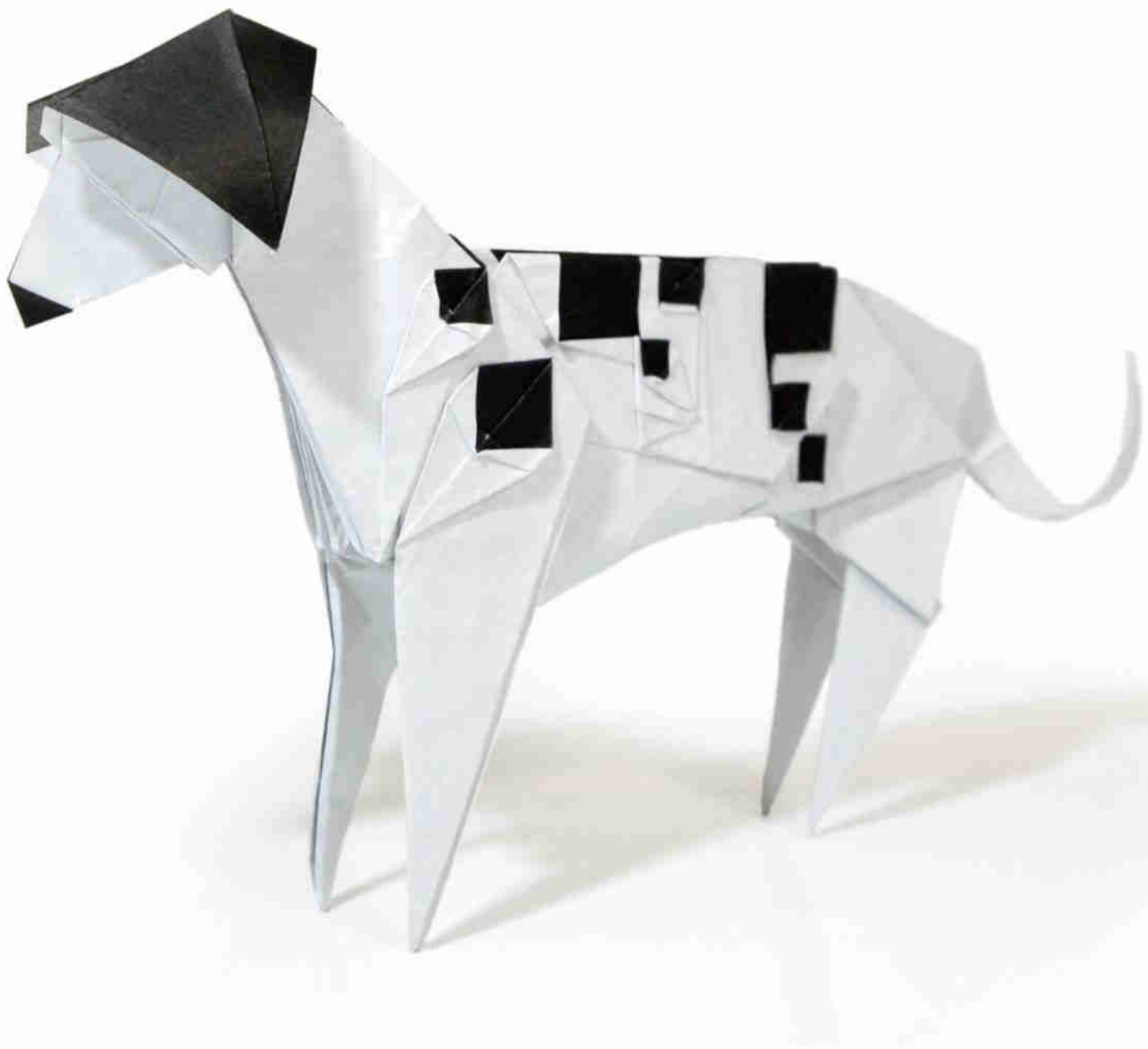

ダルメシアン
DALMATIAN ▶ P. 158

パンダ 2022
PANDA 2022 ▶ P. 080





忍者
NINJA ▶ P. 191

カラス
CROW ▶ P. 108

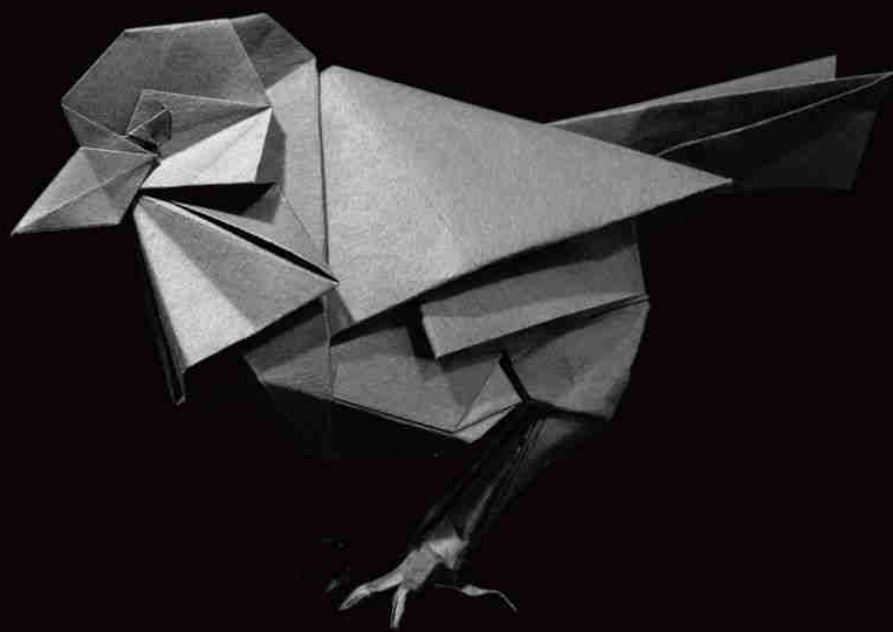

ペンギン
PENGUIN ▶ P. 025

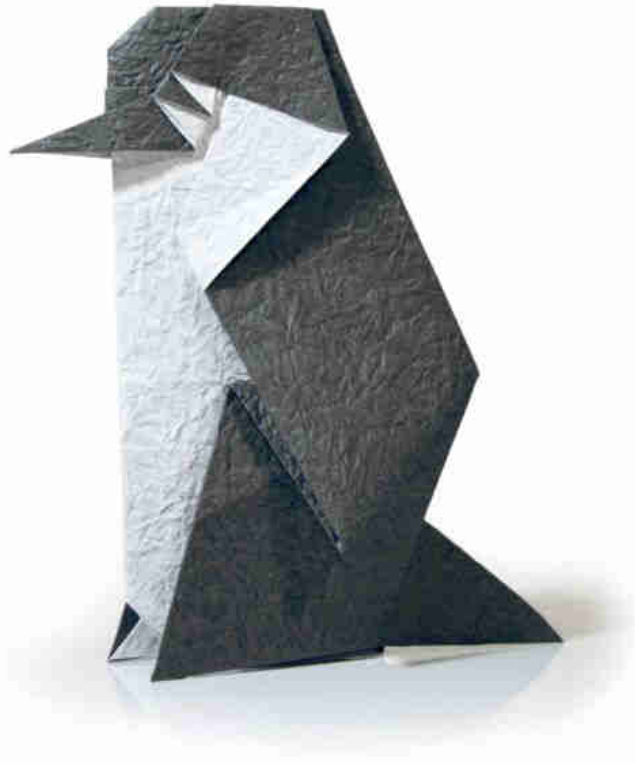

シマエナガ
LONG-TAILED TIT ▶ P. 072



ツバメ
SWALLOW ▶ P. 044



ヤマセミ
CRESTED KINGFISHER ▶ P. 050



座る猫
SIT-CAT ▶ P. 058

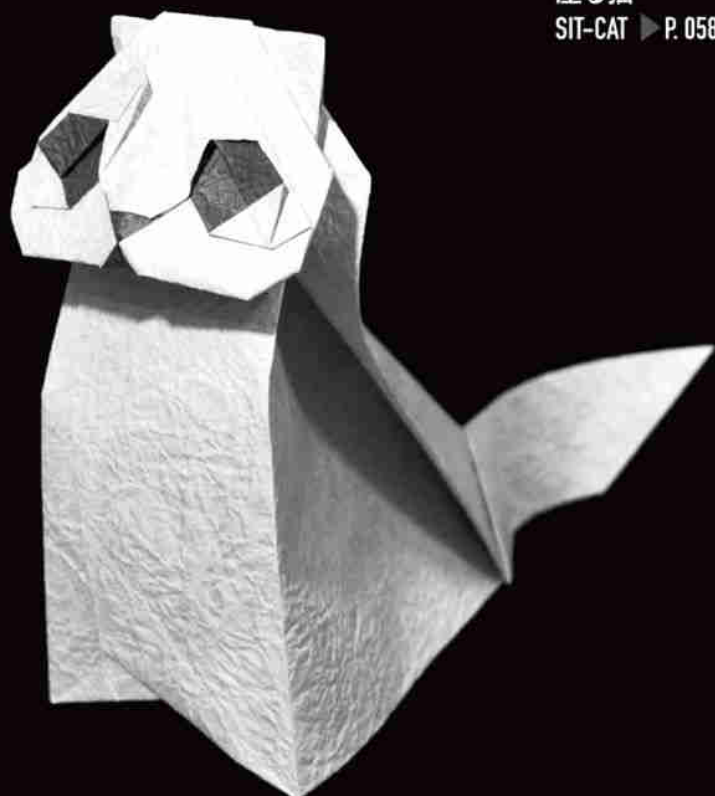

シマウマ
ZEBRA ▶ P. 119



シロクマ
POLAR BEAR ▶ P. 064

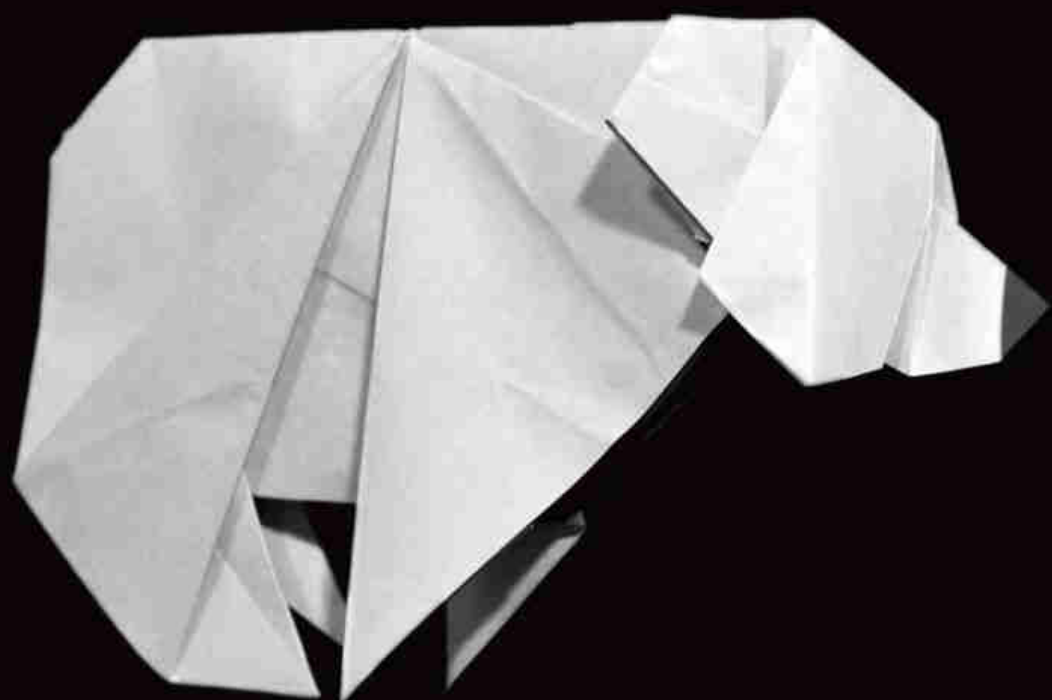

ホワイトタイガー
WHITE TIGER ▶ P. 132





牛
COW ▶ P. 097

マレーバク
MALAYAN TAPIR ▶ P. 037

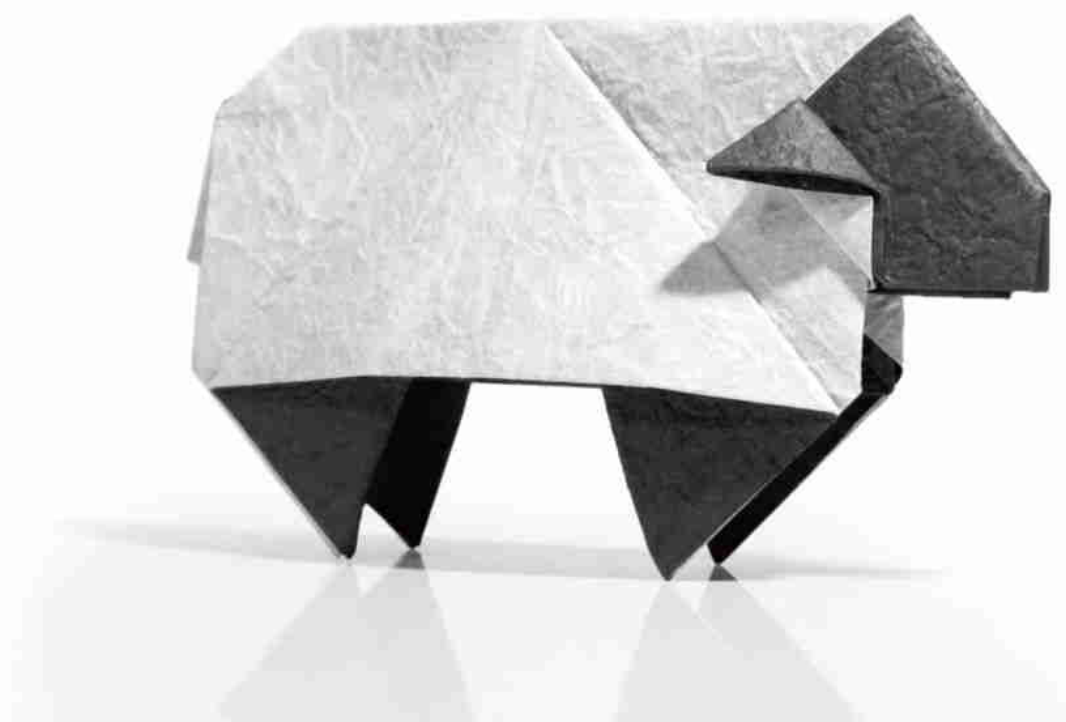

サフォーク
SUFFOLK SHEEP ▶ P. 030

シャチ
ORCA ▶ P. 088

オコジョ
ERMINE ▶ P. 148



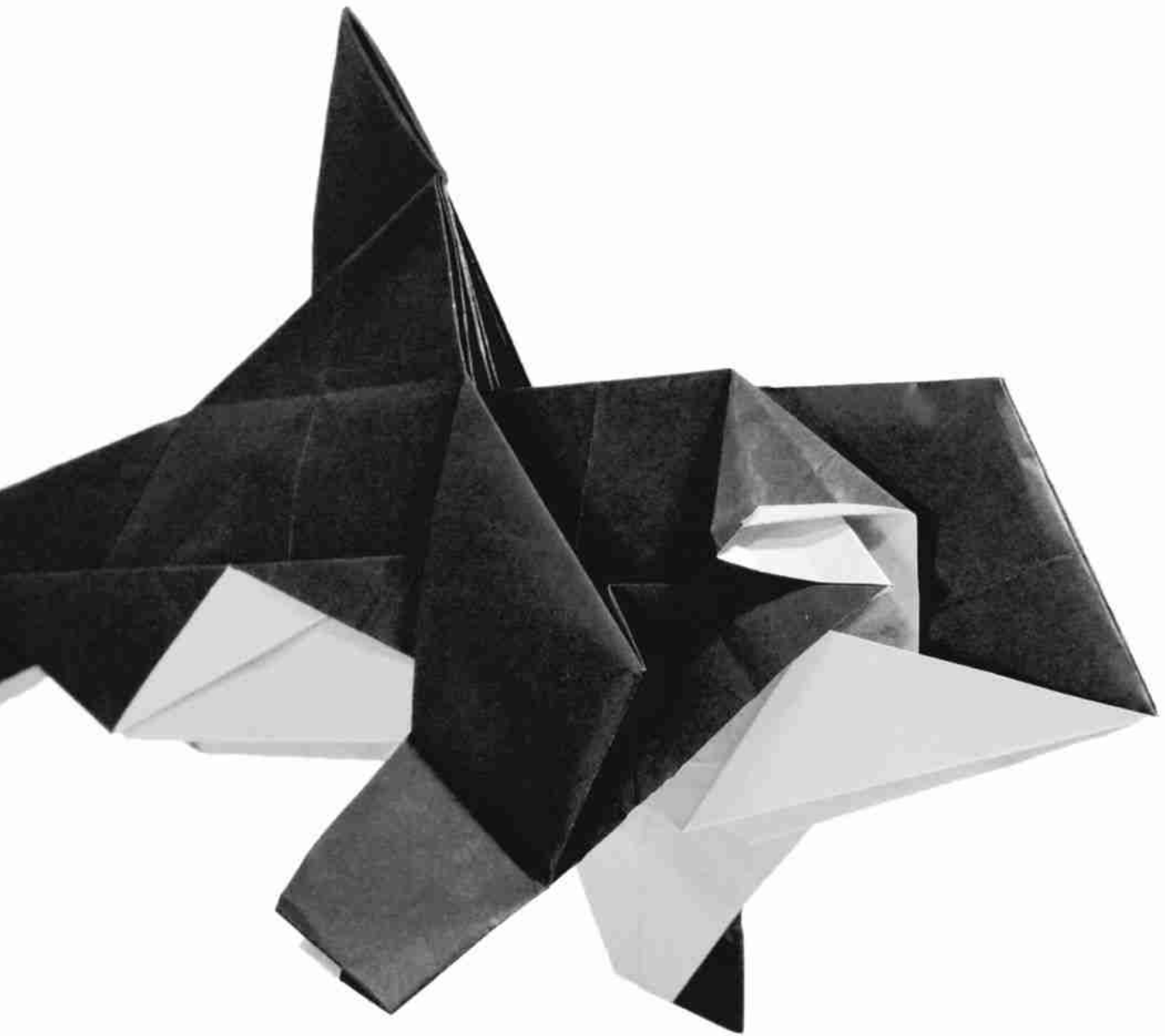

ポーン
PAWN ▶ P. 214

ルーク
ROOK ▶ P. 219

ナイト
KNIGHT ▶ P. 222



ビショップ
BISHOP ▶ P. 226

クイーン
QUEEN ▶ P. 229

キング
KING ▶ P. 233

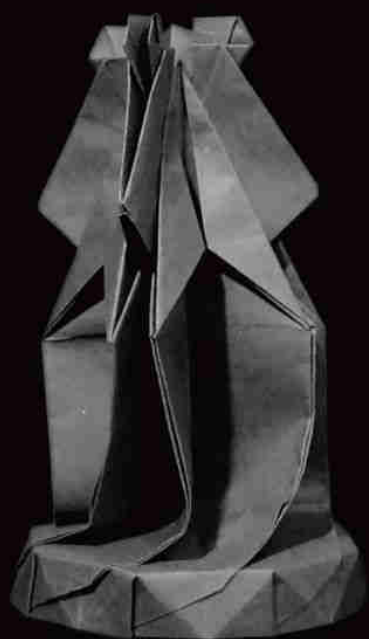

CONTENTS

ORIGAMI MONO

鶴田芳理

YOSHIMASA TSURUTA

01 ▶ P. 025



ペンギン
PENGUIN
SIMPLE



02 ▶ P. 030

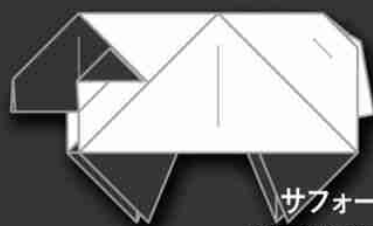

サフォーク
SUFFOLK SHEEP
SIMPLE



03 ▶ P. 037



マレーバク
MALAYAN TAPIR
INTERMEDIATE



04 ▶ P. 044



ツバメ
SWALLOW
INTERMEDIATE



05 ▶ P. 050



ヤマセミ
CRESTED KINGFISHER
INTERMEDIATE



06 ▶ P. 058



座る猫
SIT-CAT
INTERMEDIATE



07 ▶ P. 064

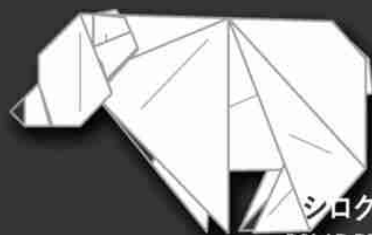

シロクマ
POLAR BEAR
INTERMEDIATE



08 ▶ P. 072



シマエナガ
LONG-TAILED TIT
INTERMEDIATE



09 ▶ P. 080



パンダ 2022
PANDA 2022
INTERMEDIATE



10 ▶ P. 088

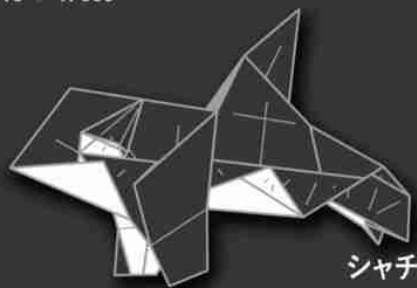

シャチ
ORCA
INTERMEDIATE



11 ▶ P. 097



牛
COW
COMPLEX



12 ▶ P. 108



カラス
CROW
COMPLEX



13 ▶ P. 119



14 ▶ P. 132



15 ▶ P. 148

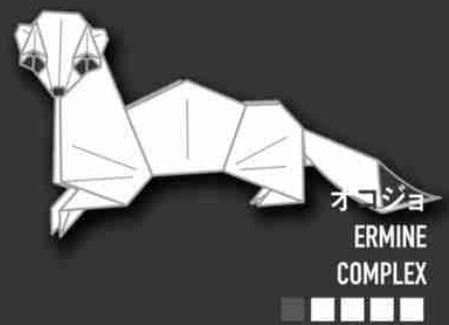

16 ▶ P. 158



17 ▶ P. 172



18 ▶ P. 191



19 ▶ P. 214



20 ▶ P. 219



21 ▶ P. 222



22 ▶ P. 226



23 ▶ P. 229



24 ▶ P. 233

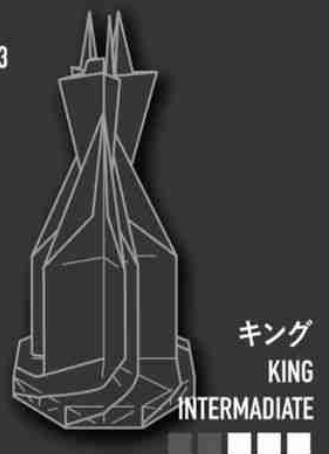

CONCEPT

ORIGAMI MONO

コンセプト
Project 2022

mo

モノ

この本はシロクロをテーマに、「折り紙の本」という物に対して少しでも見る角度を変えてみた作品集です。

“MONO”には、「単一の」「一つで」「一人で」等の意味があります。著者がそもそも白黒が好きであるということや背景に、以下の条件に絞った折り図集を製作しました。

- ・単一用紙：不切正方形1枚折り
 - ・モノクロ：白黒で表現できるモチーフ
 - ・単独企画：公募でない、初の個人製作
- 積読や#折り図は読みものといった言葉もありますが、もしよければ是非、溜まった白黒の紙を引っ張り出して本書をお楽しみ下さい。

The theme of this book is black and white. And this is one of the books that I tried to change the viewing angle a little for the "origami book".

Starting from that the author likes B&W in the first place, I made a collection of origami diagrams focusing on the following conditions.

- ・ Single paper : One uncut square paper
- ・ Monochrome: Only B&W works
- ・ Solo project : My first single-author book

Not open call for participants

There are words "Tsundoku" or "diagrams are for reading", but if you like, please dust off the accumulated B&W papers and enjoy this book.

GENERAL FLOW

ORIGAMI MONO

基本的な流れ
PROCESS

【基本形をつくる】

厳密に「ここまでが基本形」という基準はありませんが、多くの作品が前半に全体のおおよその形【基本形】を作るように折り、後半に詳細な部分を折るという手順を踏みます。基本形の状態で綺麗な左右対称かどうか、カドがズレていないかどうか等を確認して、調整しながら折り進めます。

[Make a base]

There is no strict standard that "this is the base", but many works fold to make an approximate shape [base] in the first half, and fold the detailed parts in the second half. Check if the base is beautifully symmetrical and if the edges are not misaligned, and then fold it while adjusting.

12

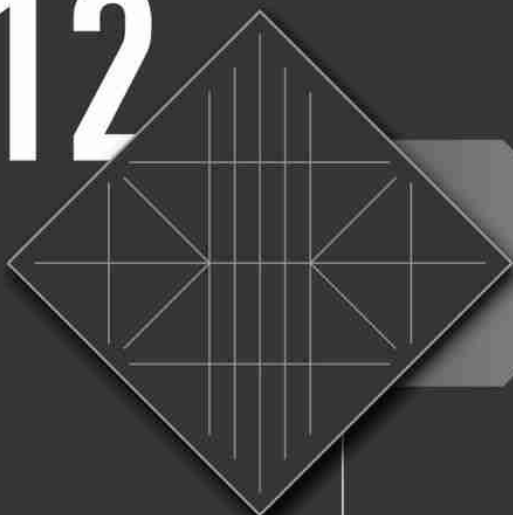

48

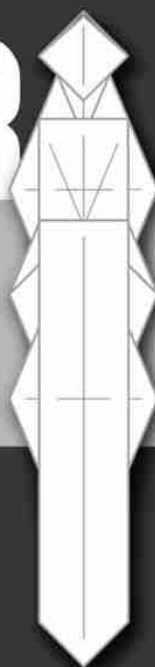

【準備する】

推奨サイズはあくまで著者が折りやすいと感じる目安です。うまく折れない場合は一回り大きな紙を使いましょう。また、完成した時に出る裏表の面を間違えないよう、先に完成ページまで軽く目を通すことをお勧めします。

【折り筋をつける】

序盤の数ミリのズレが、後半の大きなズレに繋がります。前後の工程と見比べながら正確に、丁寧に折り進めましょう。

[Prepare]

The recommended sizes are just guides for the author to feel easy to fold. If you don't fold well, use a larger paper. And it is recommended that you first skim the completed page so that you don't mistake the front and back sides of paper that appear when completed.

[Make creases]

A few millimeters of gap in the early stages will lead to a large gap in the latter half. Let's fold it accurately and carefully while comparing it with the previous and next steps.

【仕上げる】

最終工程まで折った後は、全体の形を整えます。好みが分かれるところですが、紙が開くことを防ぐため、著者は糊付けを推奨します。

また、絵画の額縁を選ぶように、折り紙の台座考えてディスプレイすることもあります。

[Shape the model]

After folding to the final step, shape the whole of the model. It depends on the person, but the author recommends gluing to prevent the paper from opening. Also, as if choosing a picture frame for a painting, we may think of an origami pedestal and display it.

99

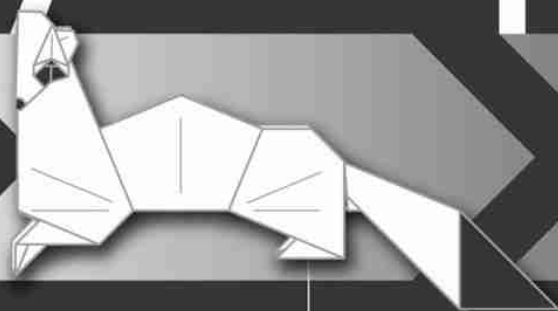

103

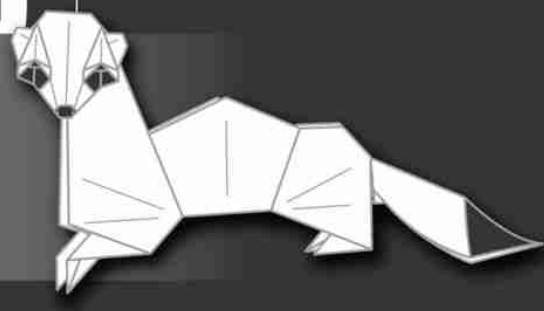

【詳細を折り込む】

基本形から最後まで工程は、細かい作業が繰り返されますので、集中して折り込んでいきます。

市販の折り紙用紙等、一般的な白黒の紙では、折っているうちに指に色が着いて白い面が汚れてしまう場合があります。こまめに指を確認し手を洗うことで、息抜きをしましょう。

[Fold details]

In the process from the base to the end, detailed work is repeated, so we will concentrate on folding.

With common black and white paper, such as commercial origami paper, the white side may become stained with black paint while folding. Take breaks to check your fingers frequently and wash your hands.

Symbols & Basic Techniques



谷折り
Valley fold



山折り

Mountain fold

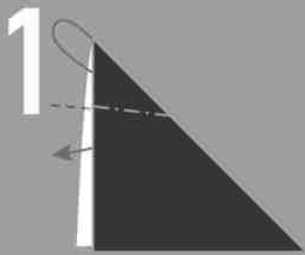

中割り折り
Inside reverse fold.

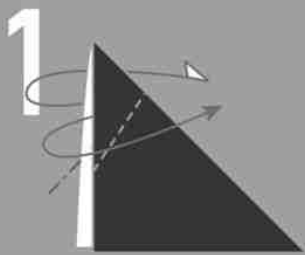

かぶせ折り
Inside reverse fold.



広げて沈め折り
Open sink.



一度広げて沈める
Spread once and sink.

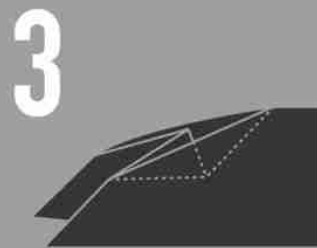

閉じたまま沈め折り
Closed sink.



カドを押し込んで沈める
Push the corner and sink.



PENGUIN

ORIGAMI MONO

ペンギン
2022



PENGUIN

☑ 15cm×15cm
SIMPLE

白黒の動物といえば、パンダです。これは揺るぎません。ペンギンは8番目ぐらいに思い浮かんだのですが、作品がシンプルで導入に相応しいかなと思ったため1番目に持ってきました。

2014年頃に「赤ちゃんペンギン」という作品を創作したことがあります。その時は蛇腹を使っており、シンプルな見た目の割に分厚かったのですが、今回は厚みが分散されて、折れやすくなったと思います。

Speaking of black and white animals, they are pandas. This is unwavering. The penguins came to my mind about the 8th, but I brought it to the 1st work of this book because I thought the work was simple and suitable for intro.

Around 2014, I have created a work called "Baby Penguin". At that time, I used box pleating, and it was thick despite its simple appearance, but this version I think that the thickness is dispersed and it is easier to fold.

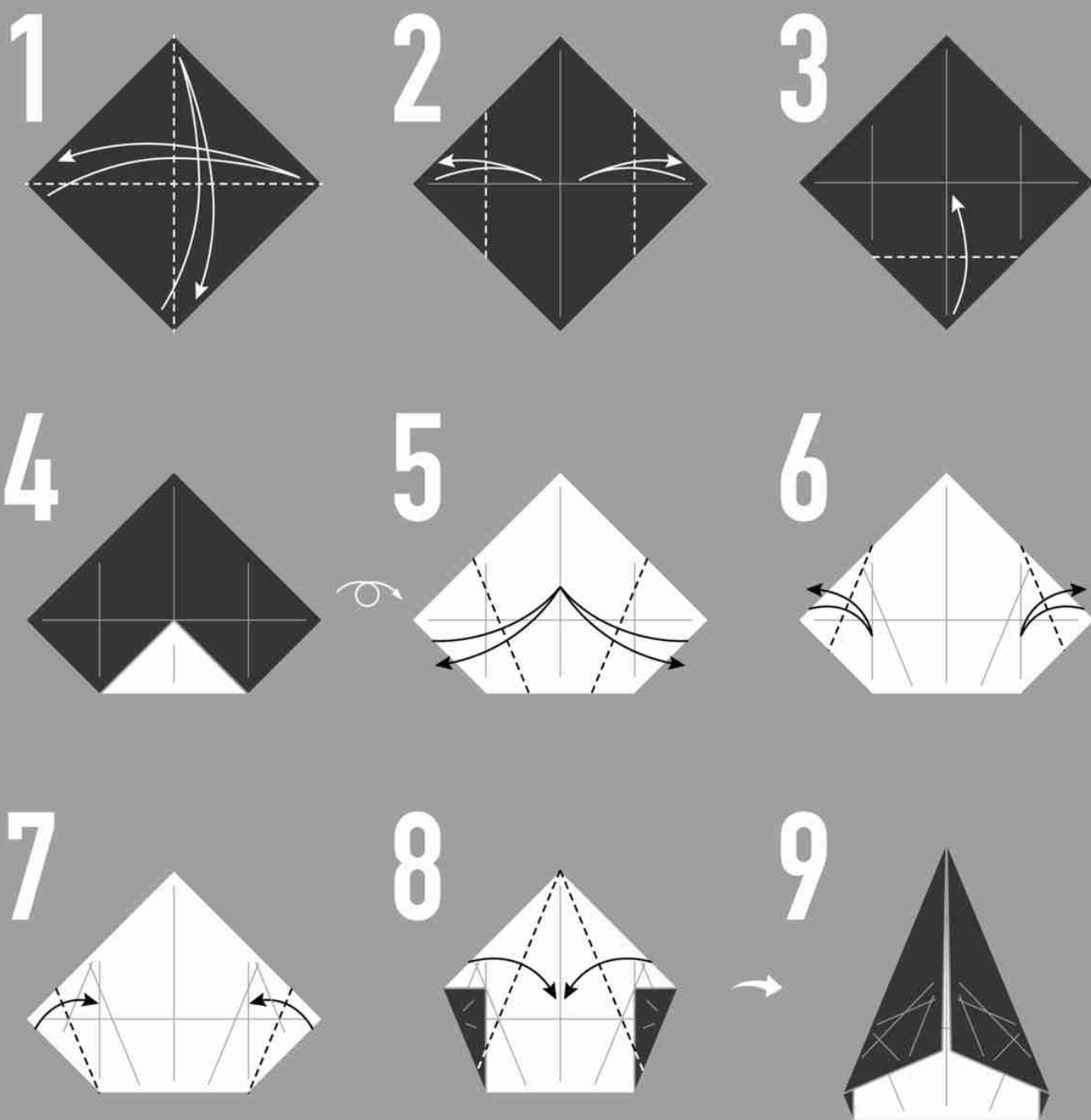

10



11

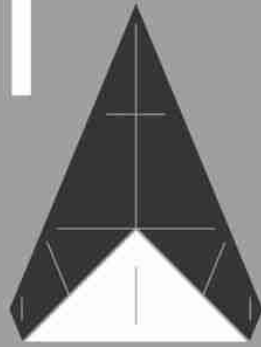

12



折り筋をつけ直す
Re-crease the existing crease lines.

13

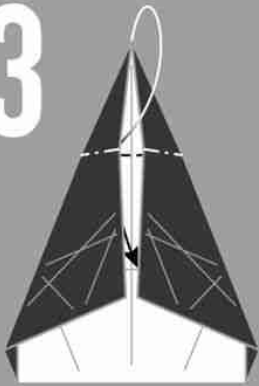

中割り折り
Inside reverse fold.

14

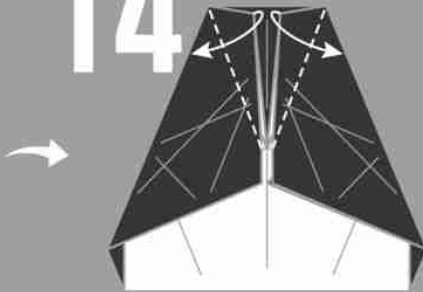

15



16



17



引き寄せるように折る
Swivel inside.

18



19



引き寄せるように折る
Swivel inside.

20



21

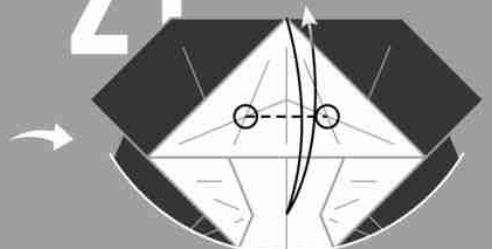

PENGUIN

22

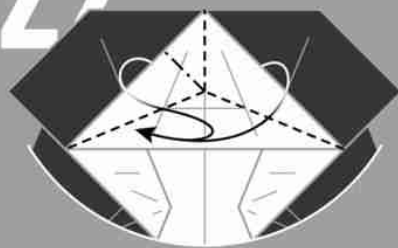

カドをつまむように折る
Rabbit ear fold.

23

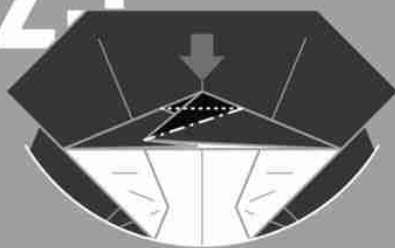

広げて沈め折り
Open sink.

24



25



26



内側のカドを引き出す
Pull out the inner corner.

27

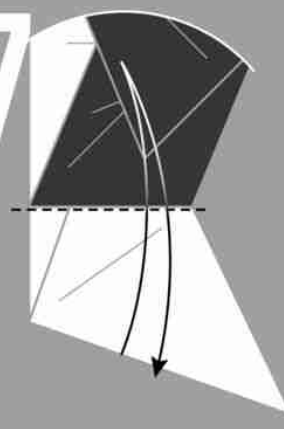

28



閉じたまま沈め折り
Closed sink.

29

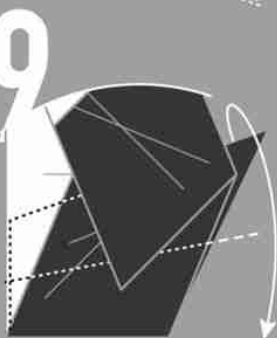

30



カドを軽くめくる
Open the corner lightly.

31



32



中割り折り
Inside reverse fold.

33



カドを閉じる
Close.

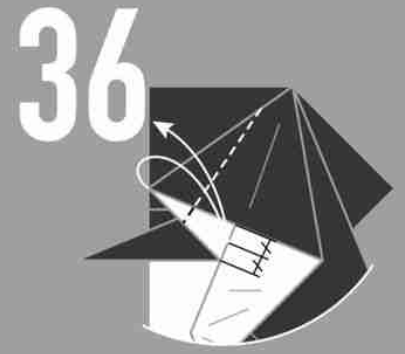
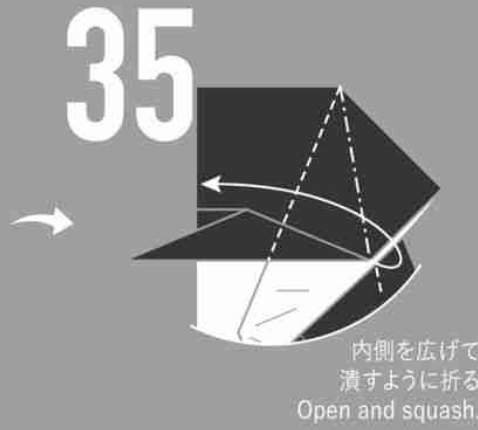

中割り折り
Inside reverse fold.

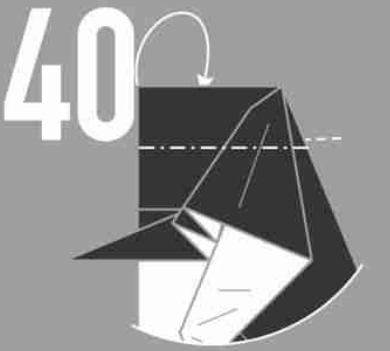
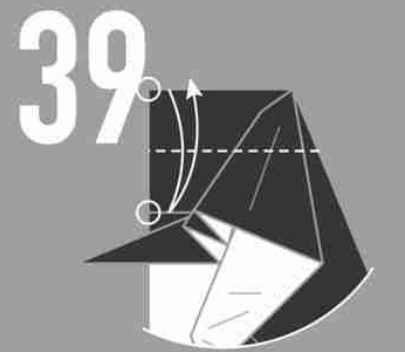
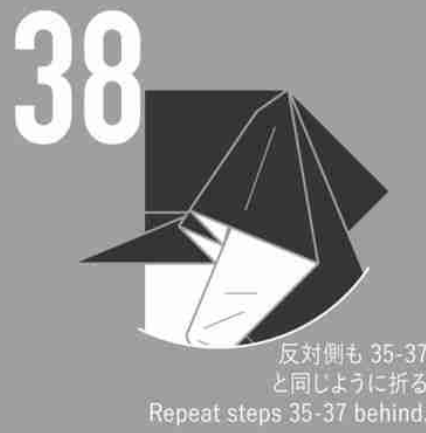

中割り折り
Inside reverse fold.



中割り折り
Inside reverse fold.

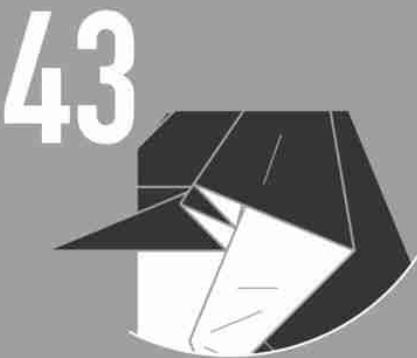

完成
Model completed.

SUFFOLK SHEEP

ORIGAMI MONO

サフォーク
2022

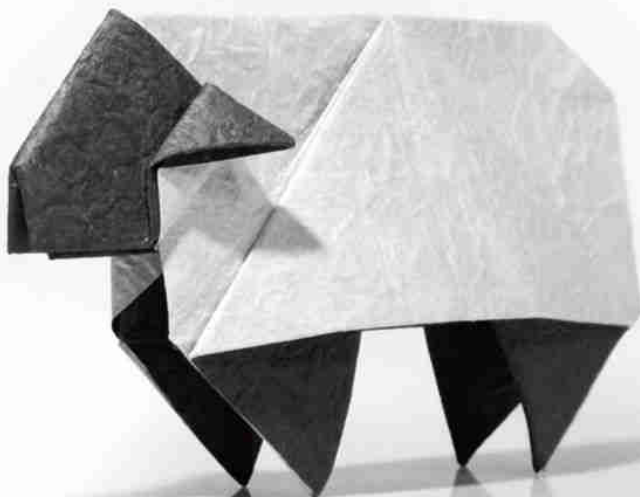
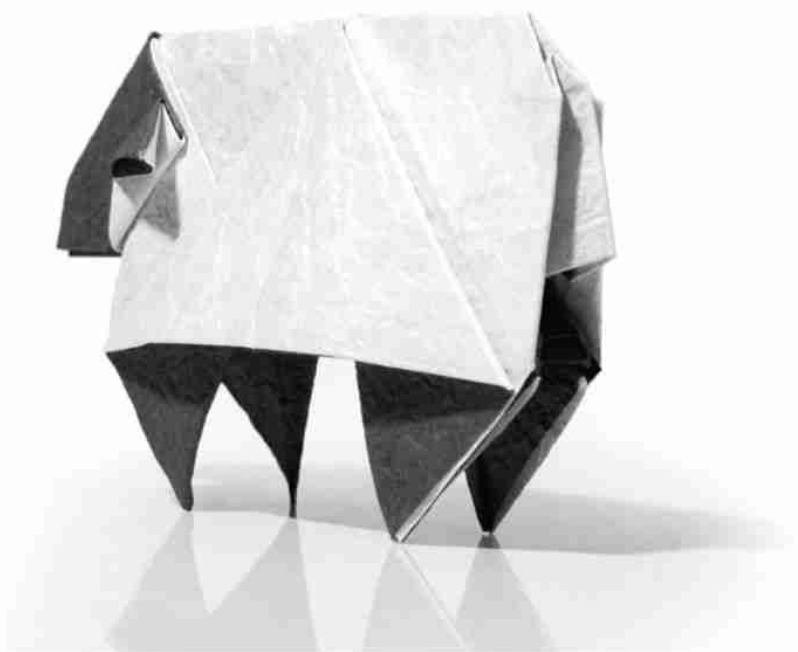

2014年頃に同じサフォークモデルの羊を創作していましたが、羊毛で全体を誤魔化し後脚が無いものでした。本作ではしっかりと後脚を折り出し、シンプルに仕上げました。

日本語のタイトルは迷いました。サフォークは本来イギリスにある州の名前であり、サフォーク単体で発表することには違和感があったためです。あくまでも個人的な感想ですが、しかしサフォークシープのシープ側を使ってしまうと、白黒の羊ですよ感が薄まってしまいます。どうするか悩んでいましたが、いつものように羊肉を検索していると、サフォークで通じているようでしたので、それに倣いました。

I had created the same Suffolk model sheep around 2014, but it was entirely fooled with wool and had no hind legs. In this work, I folded the hind legs firmly and made it simple.

I was not sure about the Japanese title. "Suffolk" was originally the name of the state in the United Kingdom, and it was uncomfortable to announce "Suffolk" alone. It's just my individual impression. However, if I use the "Sheep" side of the Suffolk sheep, then the meaning of black and white disappears. I was worried, but when I searched for lamb meat as usual, it seemed to be familiar in "Suffolk" alone in Japanese, so I name it.

15cm×15cm
SIMPLE

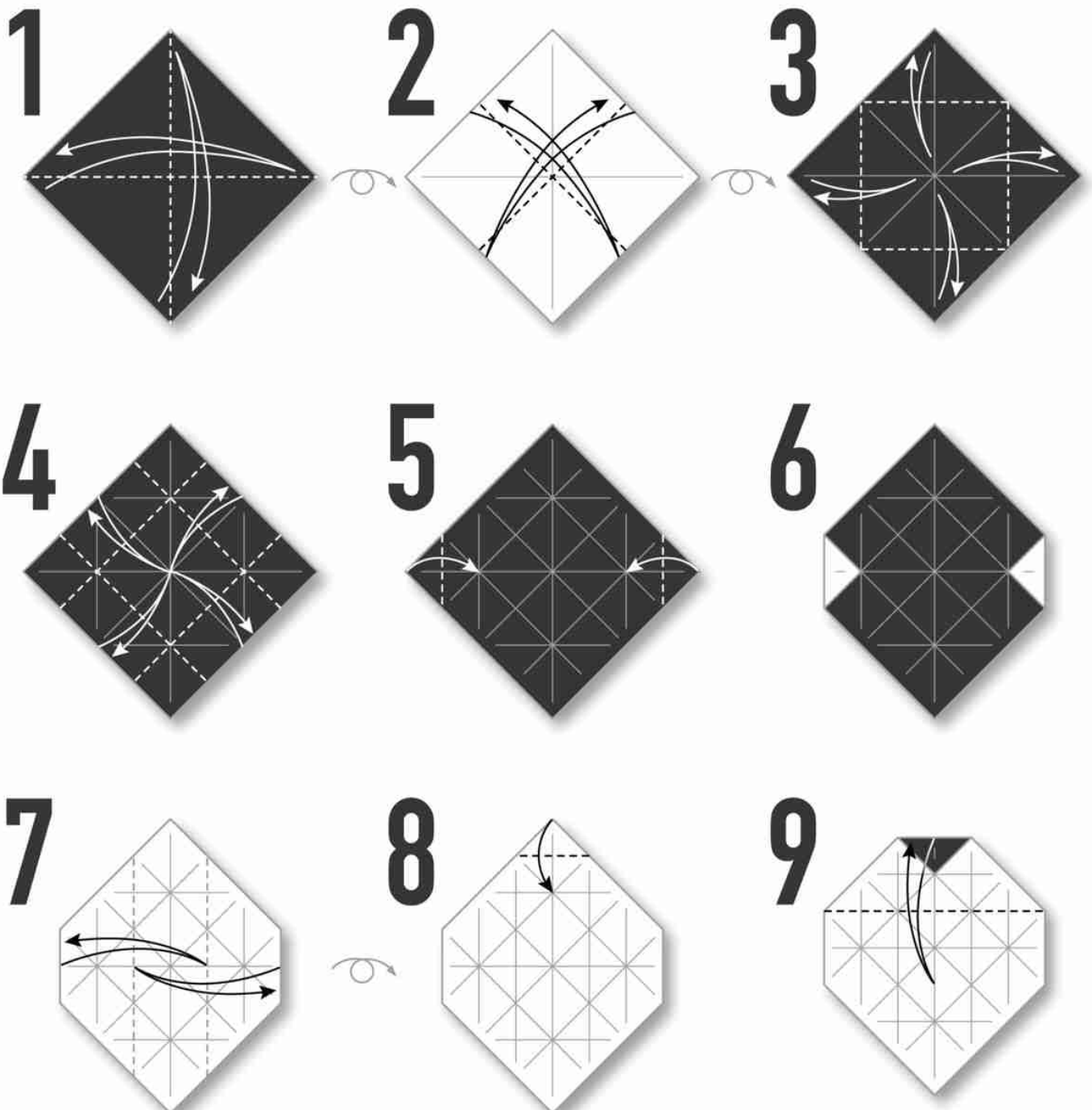
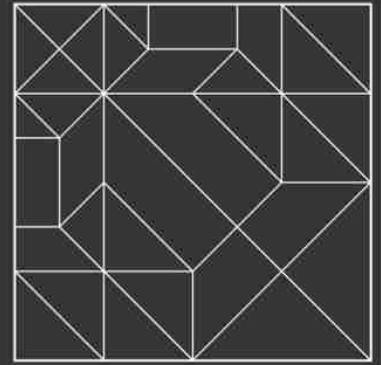

SUFFOLK SHEEP

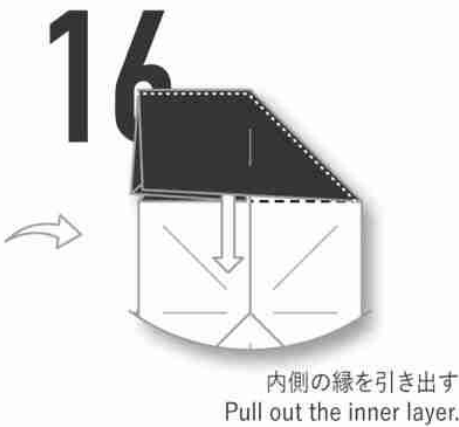
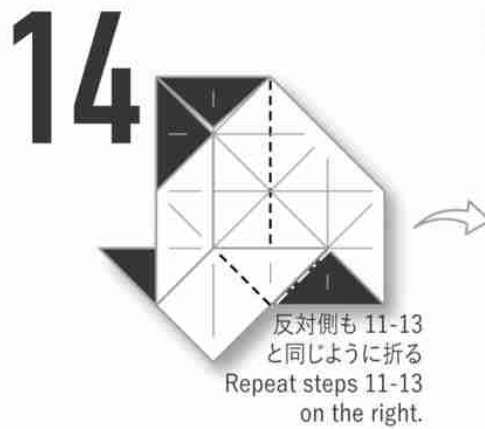
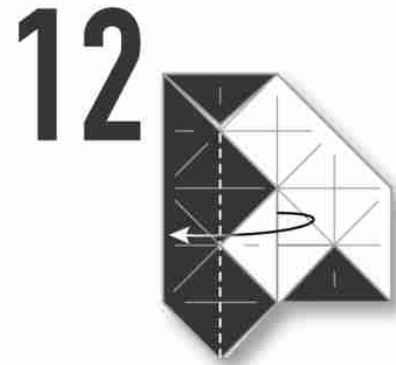
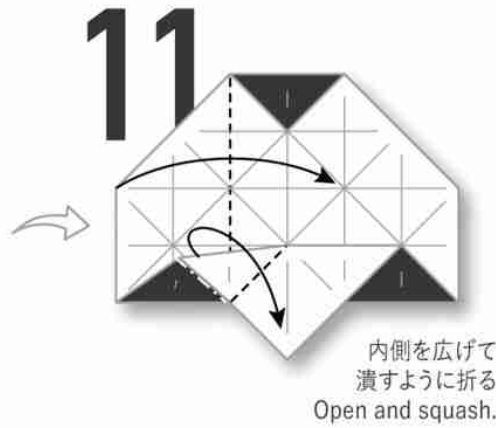
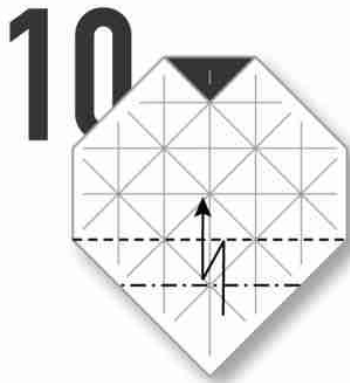

22

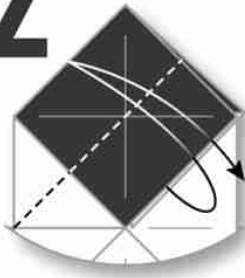

23

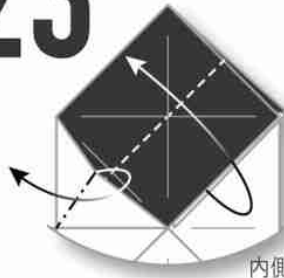

内側を広げて
潰すように折る
Open and squash.

24

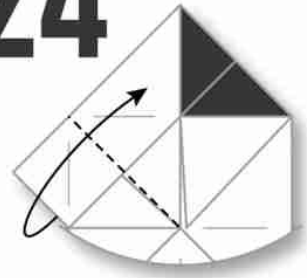

25



閉じたまま沈め折り
Closed sink.

26



内側を広げて
潰すように折る
Open and squash.

27



28

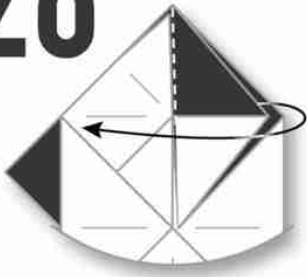

29



反対側も 20-27
と同じように折る
Repeat steps 20-27 on the right.

30

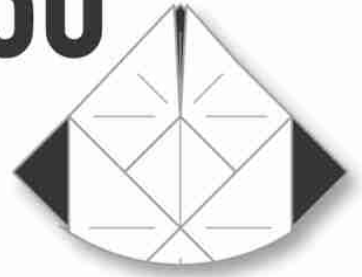

31



32

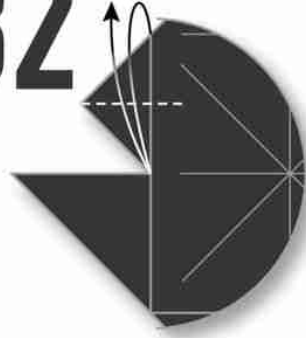

33

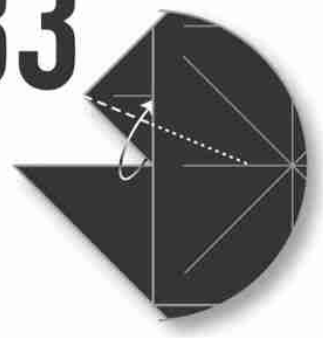

SUFFOLK SHEEP

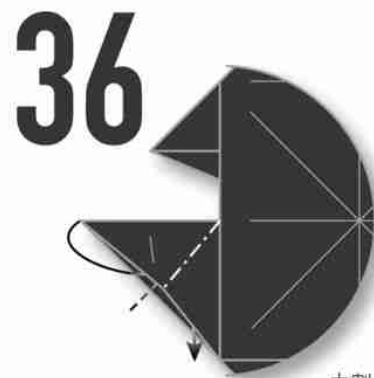

中割り折り
Inside reverse fold.



手前のカドを
隙間に差し込む
Fold the top corner into the pocket.

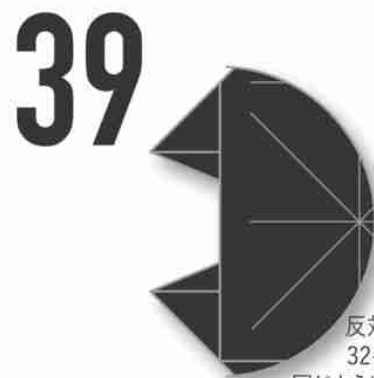
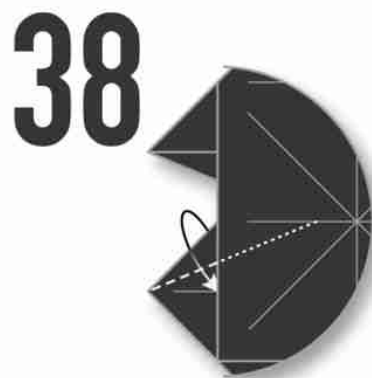

反対側も
32-38と
同じように折る
Repeat steps 32-38 on the right.

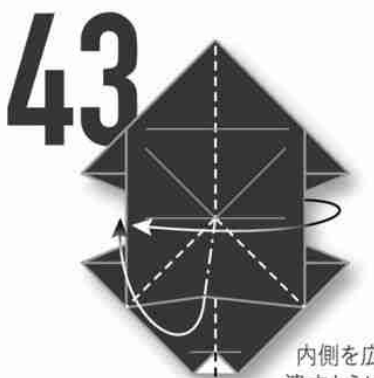
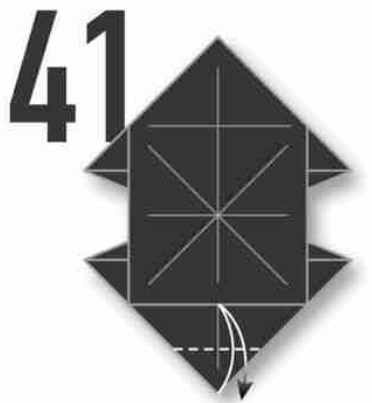

内側を広げて
潰すように折る
Open and squash.

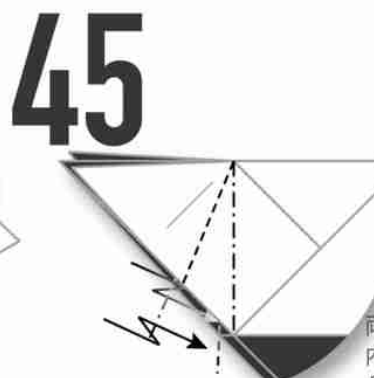
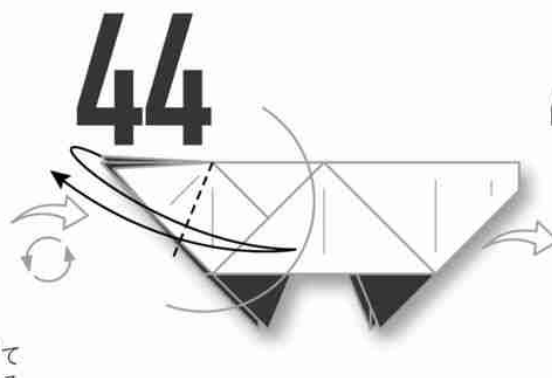

両側で
内側に
段折り
Crimp inside.

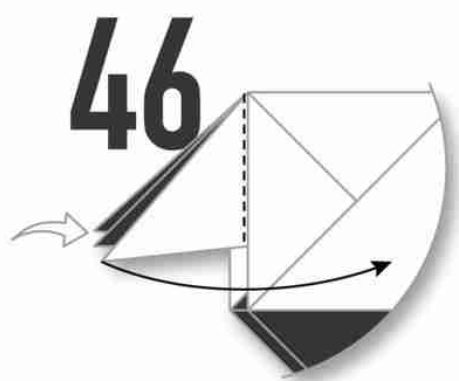

反対側も
46-48 と
同じように折る
Repeat steps 46-48 behind.



中割り折り
Inside reverse fold.

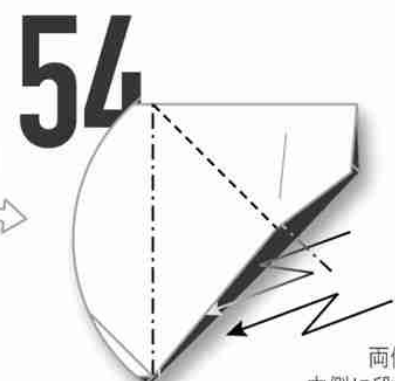
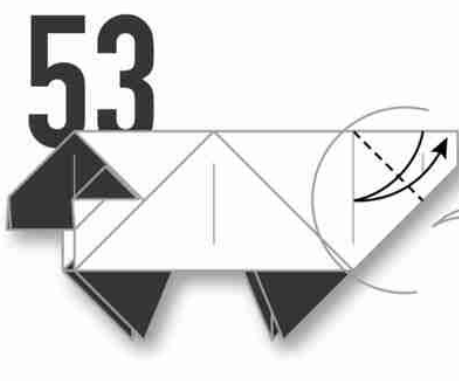

両側で
内側に段折り
Crimp inside.

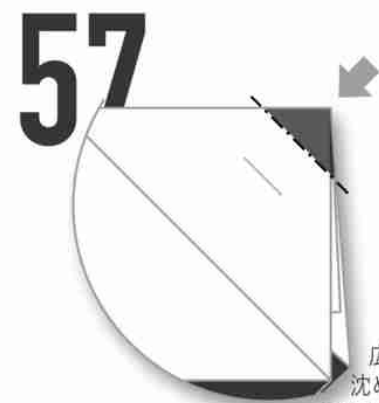
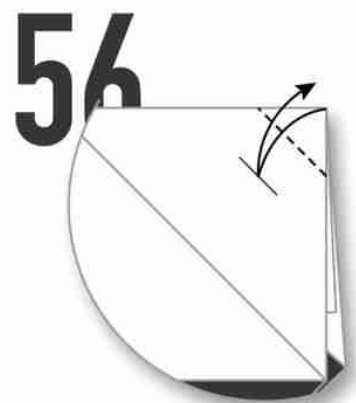
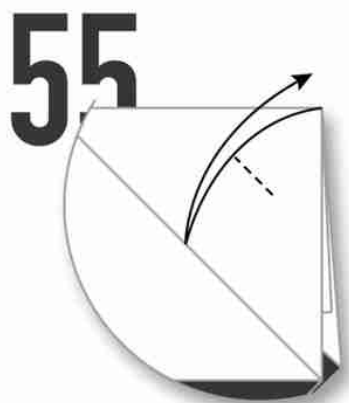

広げて
沈め折り
Open sink.

SUFFOLK SHEEP

58

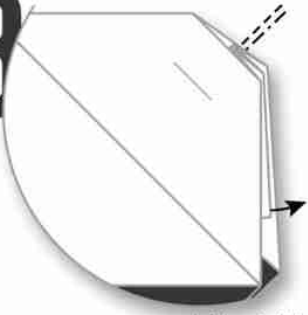

内側のカドを
引っ張って僅かにずらす
Pull out the inner corner lightly.

59



60

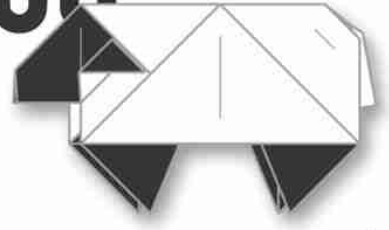

完成
Model completed.

MALAYAN TAPIR

ORIGAMI MONO

マレーバク
2022

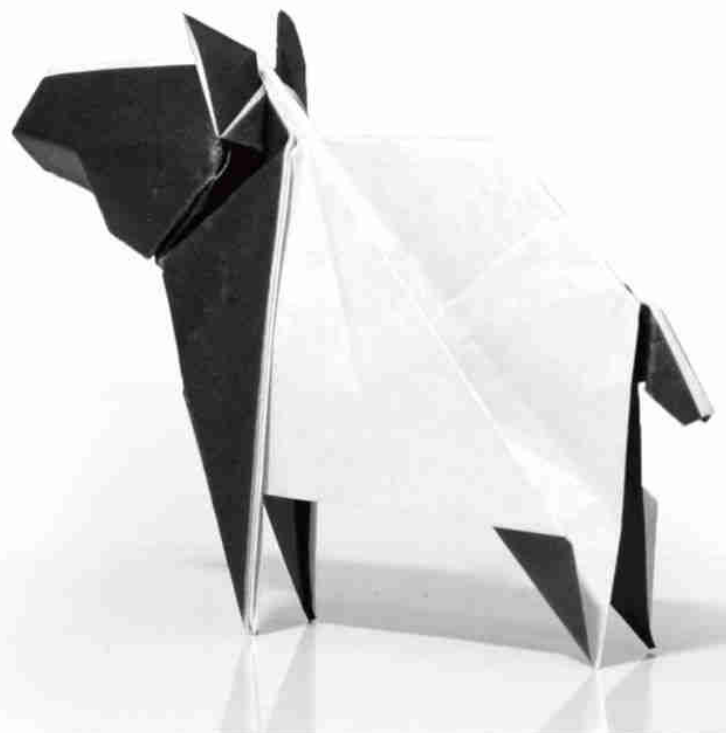
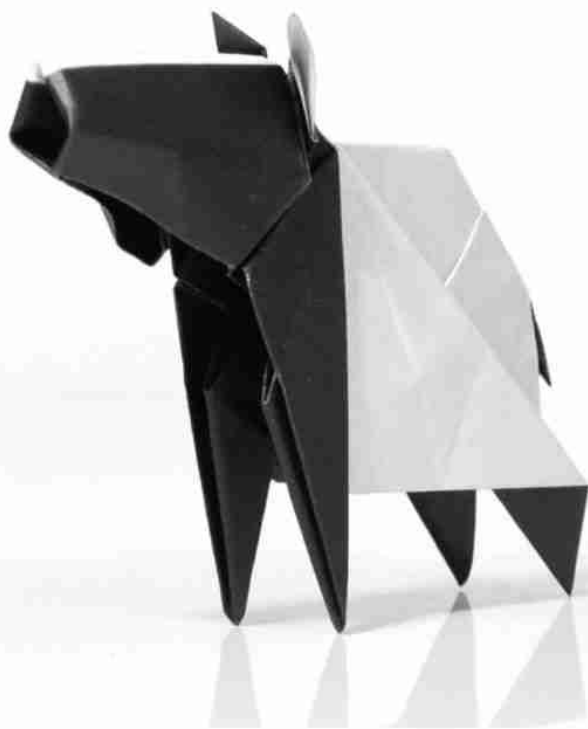

MALAYAN TAPIR

15cm×15cm

INTERMEDIATE



白黒のドラフト会議があったとすれば、上位指名間違いなしのマレーバクを創作しました。少なくともペンギンよりは上位です。

座布団小鳥の基本形(13工程までの形)から創作しました。この基本形はかなり万能で、動物の創作で行き詰まった時には、気づけば使っています。特に今回は、インサイドアウト(色変え)が必須の対象で、中々スムーズに完成に至らず、この折り方に辿り着きました。

If there was a draft meeting of black and white, Malayan tapir would definitely be picked early. At least he is higher than penguins.

Created from the blintz little bird base (step 1 to 13). This base is quite versatile, and I use it when I find myself stuck in the creation of animals. Especially this time, inside-out (color change) is an indispensable target, and it did not reach completion smoothly, so I arrived at this folding method.

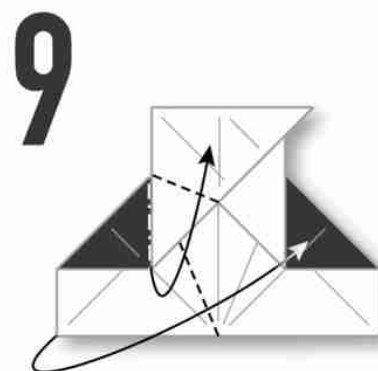
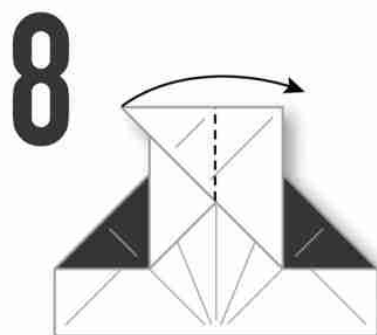
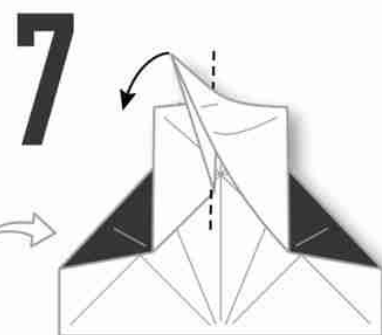
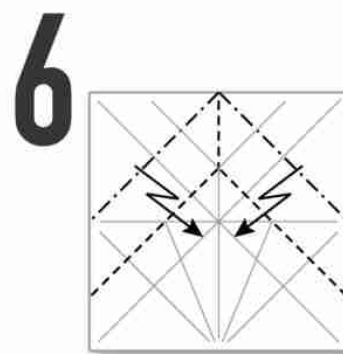
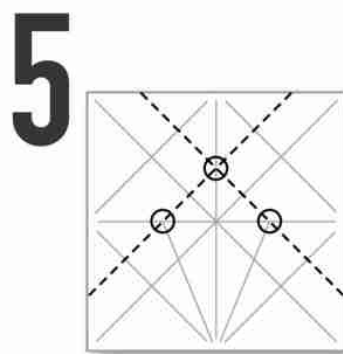
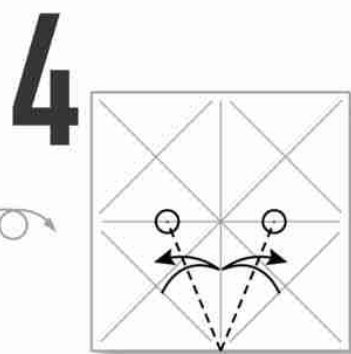
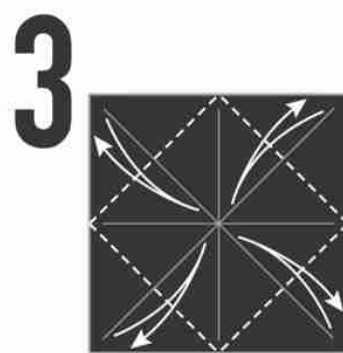
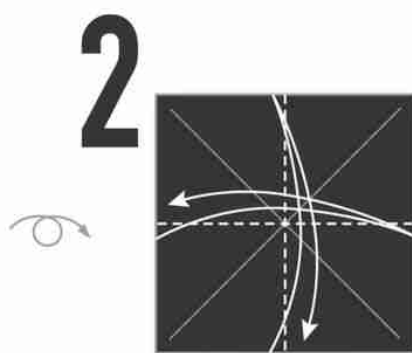
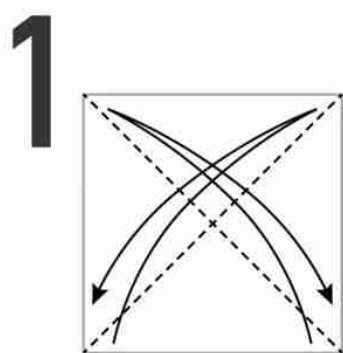
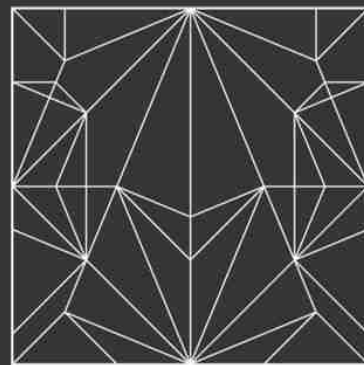

10

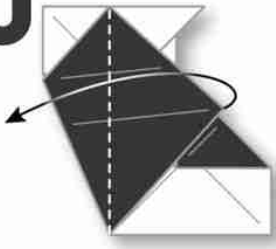

11

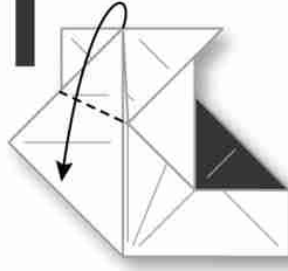

12

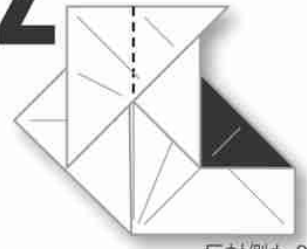

反対側も 8-11
と同じように折る

Repeat steps 8-11 on the right.

13

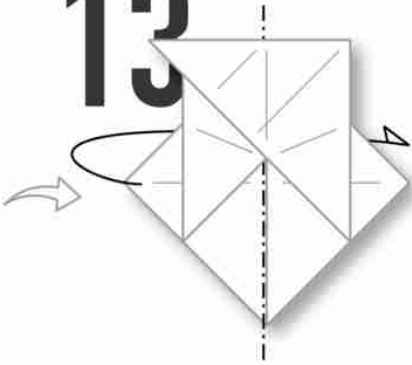

14

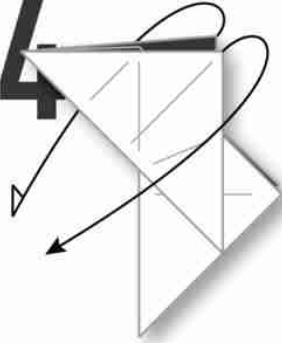

15

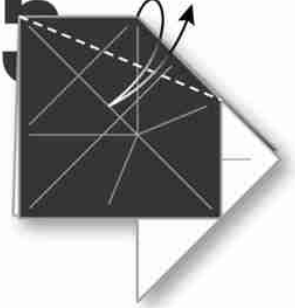

16

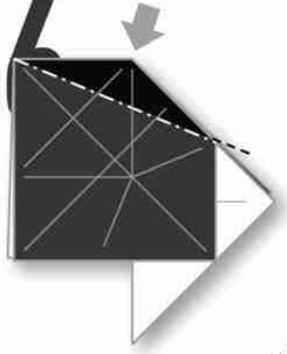

広げて
沈め折り
Open sink.

17

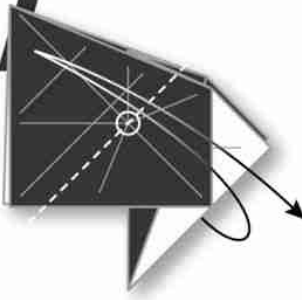

18

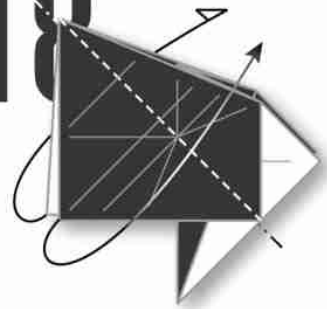

19

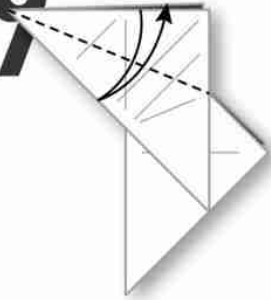

20

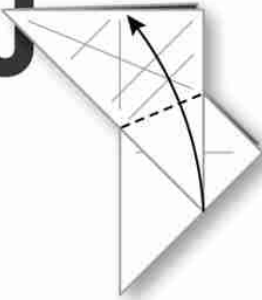

21

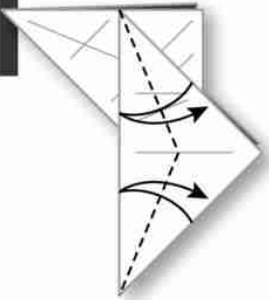

MALAYAN TAPIR

22

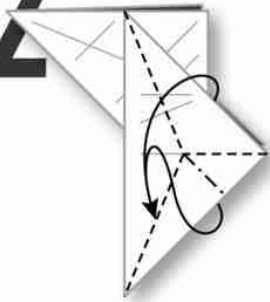

カドを
つまむように折る
Rabbit ear fold.

23



24

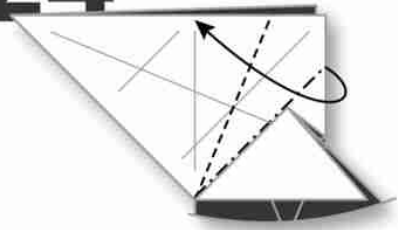

縁を引き寄せるように折る
Swivel fold.

25

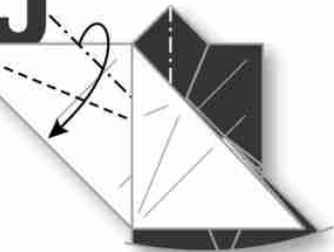

縁を引き寄せるように折る
Swivel fold.

26

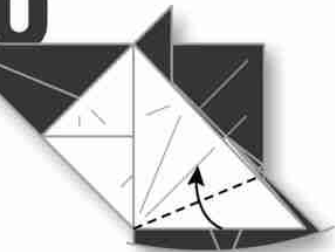

27



28

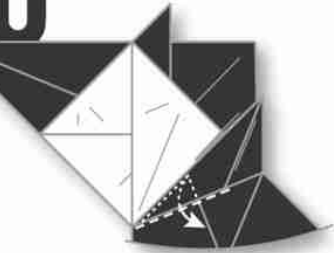

内側のカドを引き出す
Pull out the inner corner.

29

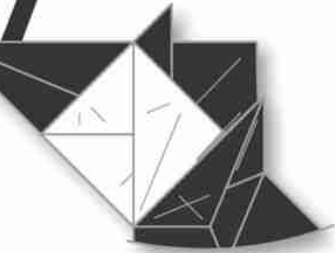

裏側も 19-28 と同じように折る
Repeat steps 19-28 behind.

30

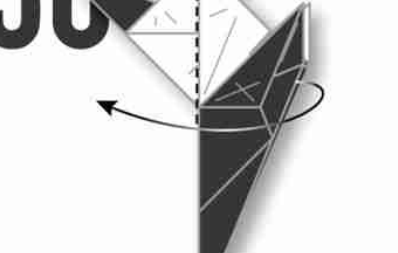

31

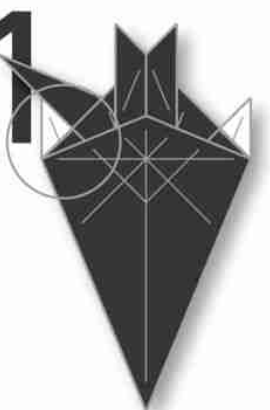

32



内側の
縁のみ
引き寄せ折り
Swivel inside only the inner corner.

33

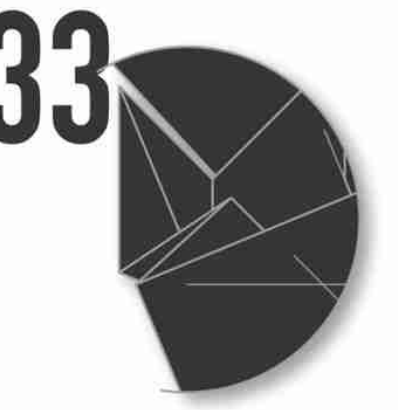



手前の
縁を折る
平面には
ならない
Fold the
top layer.
Not flat.



左のカドを
ついている
折り筋で
折りながら
全体が平面に
なるように畳む

Fold the
left corner
using the
existing crease
line and flatten.



反対側も
32-36と
同じように
折る
Repeat
steps 32-36
on the right.

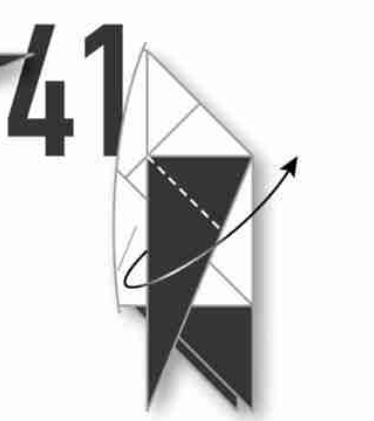
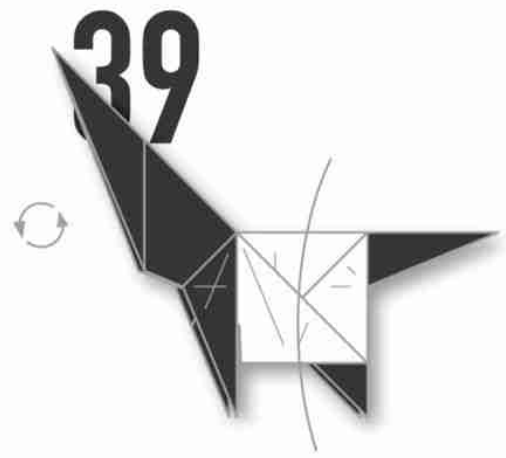

40の
状態に戻す
Unfold
to step 40.

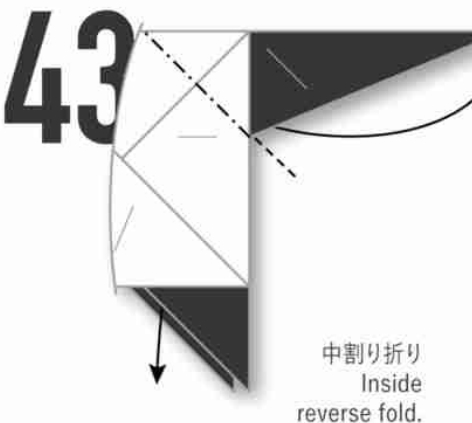

中割り折り
Inside
reverse fold.

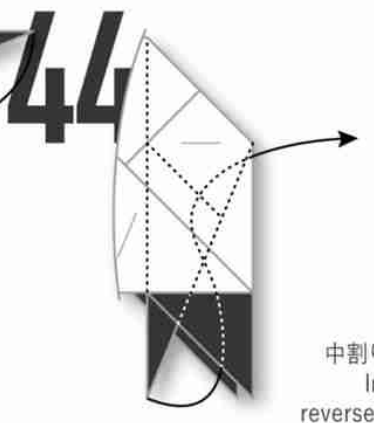

中割り折り
Inside
reverse fold.



MALAYAN TAPIR

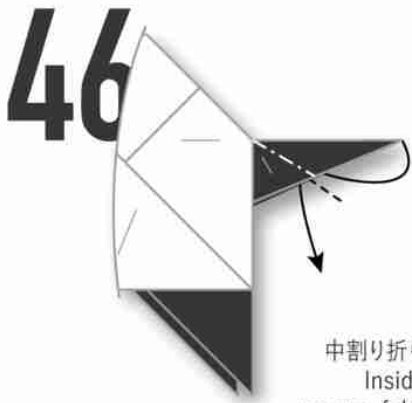

中割り折り
Inside
reverse fold.



中割り折り
Inside
reverse fold.

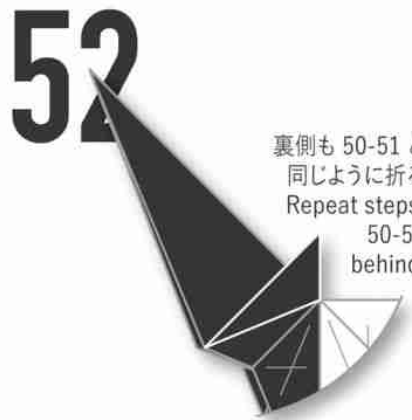

裏側も 50-51 と
同じように折る
Repeat steps
50-51
behind.

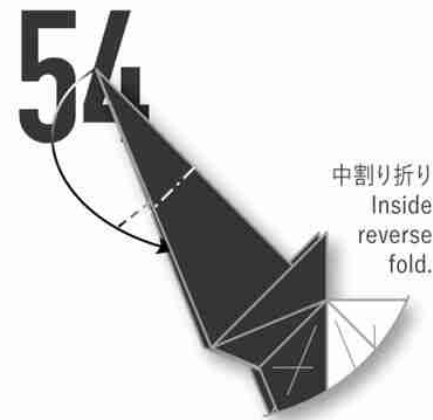
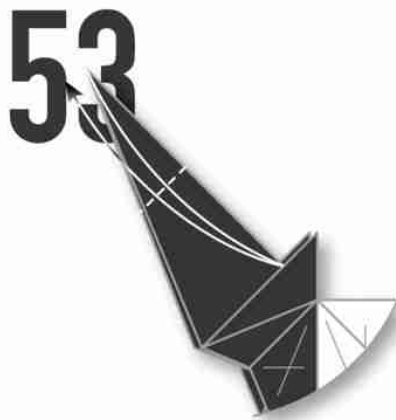

中割り折り
Inside
reverse
fold.

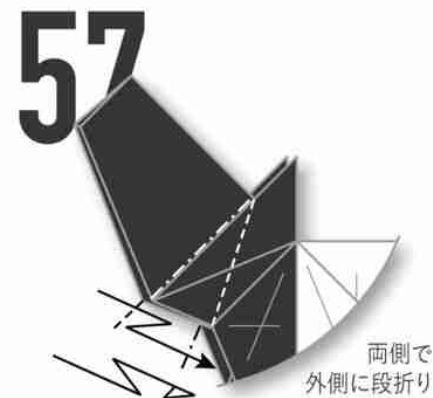
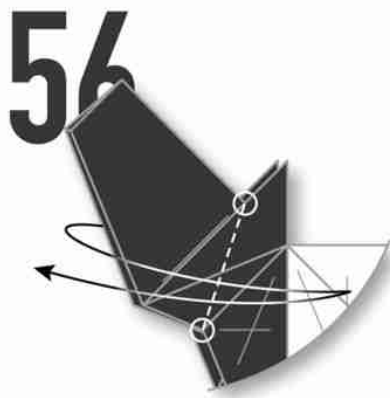

両側で
外側に段折り
Crimp outside.

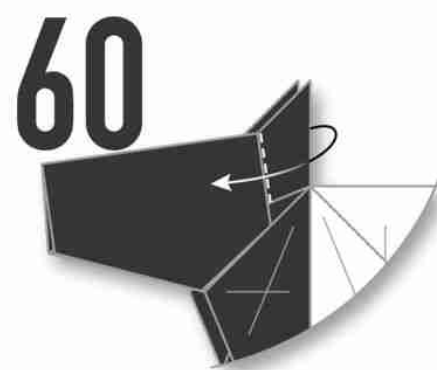
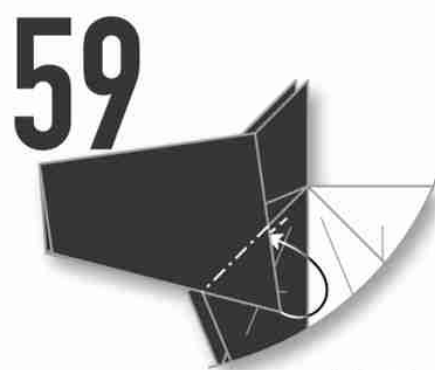
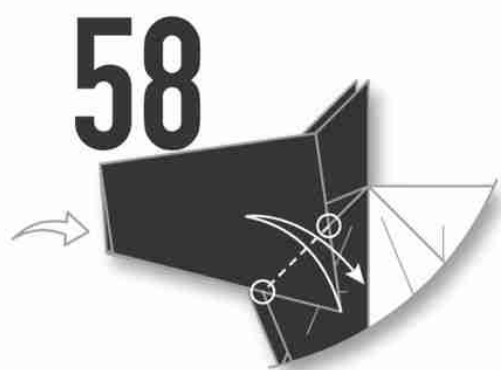

中割り折り
Inside reverse fold.

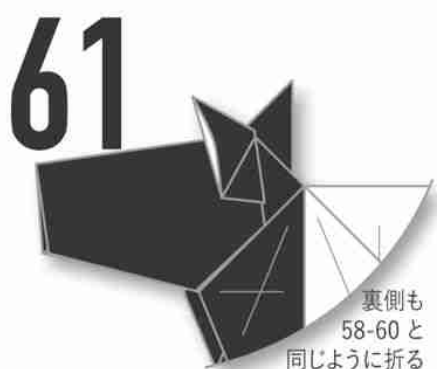

裏側も
58-60と
同じように折る
Repeat steps
58-60 behind.

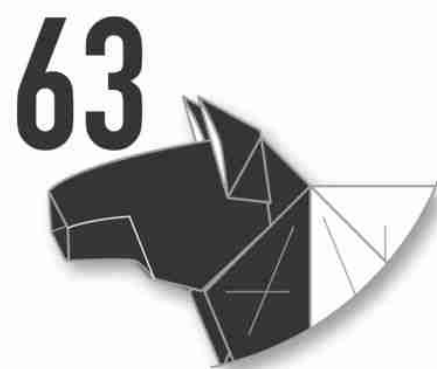
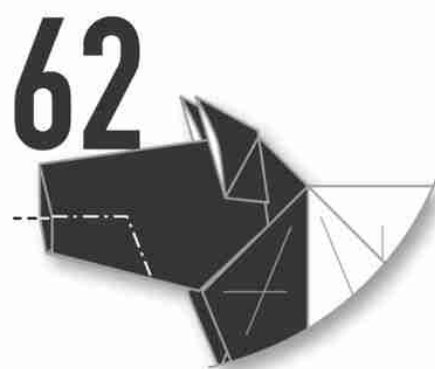

完成
Model completed.

SWALLOW

ORIGAMI MONO

ツバメ

2022

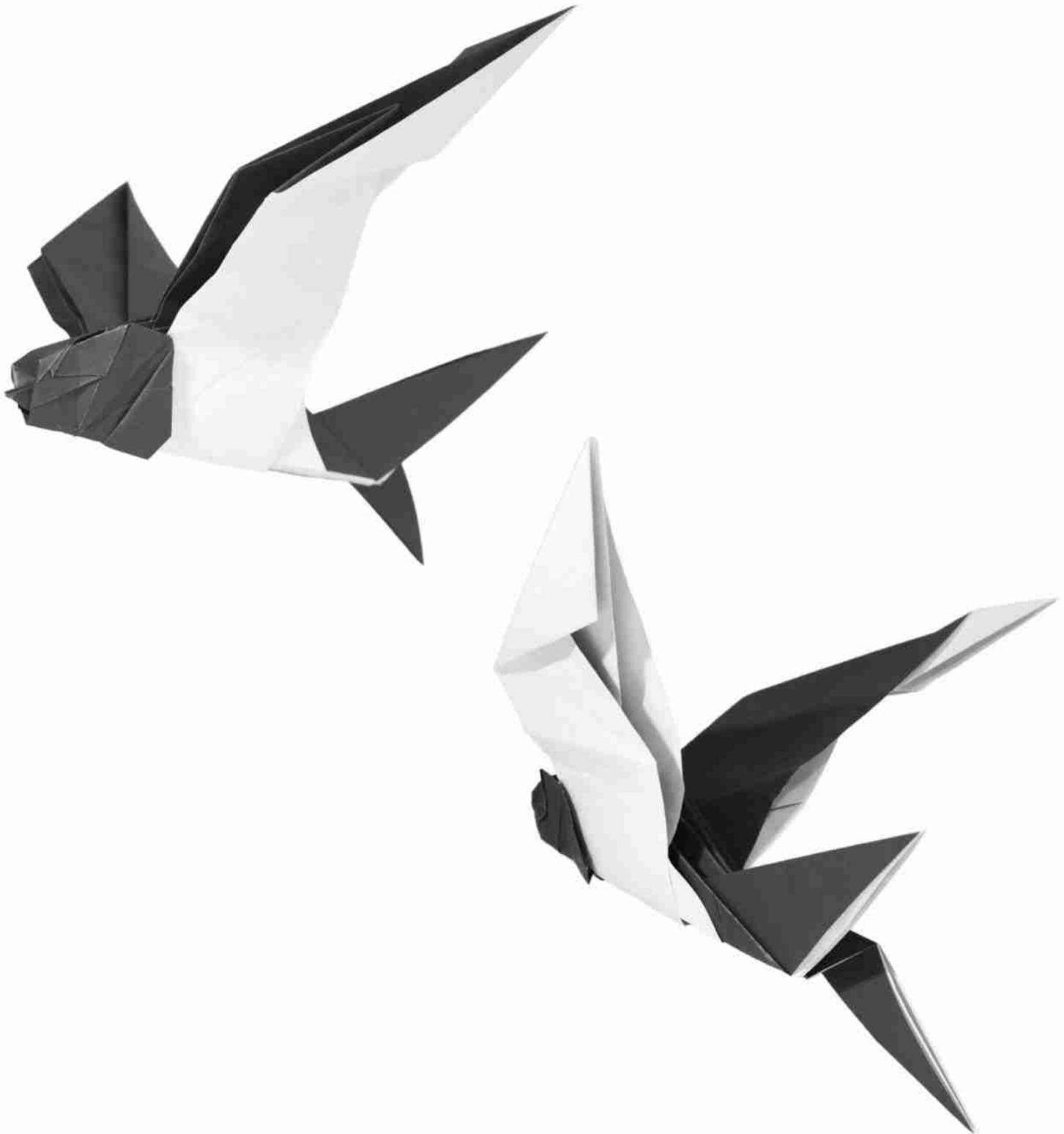

白黒のドラフト会議があったとすれば、指名する側に居座るツバメを創作しました。野球の例えが続きましたが、私は野球未経験どころかテレビでもあまり見ません。なのに使ってしまう辺り、野球の力は凄いですね。

この作品はアヤメの基本形から製作していますが、恐らく他の創作家で似たような手段を選んでいる方も多いのではないかと思います。可能な限りツバメの作品を調べ、最終的な仕上がりは独自のものにしたつもりですが、もし被っていた場合は教えてください。よくある基本形からよくあるモチーフを創作する場合は、このような被りを気にしなくてはいけません。

If there was a draft meeting of black and white, the swallow would be on the picking side (there is a team called Swallows in Japan). I don't watch baseball much on TV, but I used the analogy of baseball. The power of baseball is amazing.

This work is made from the frog base, but I think that there are probably many other creators who have chosen similar means. I looked at the swallow's work as much as possible and made the final finish unique, but please let me know if you found the same. When creating a model from a common base, we have to worry about such a same pattern.

24cm×24cm
INTERMEDIATE

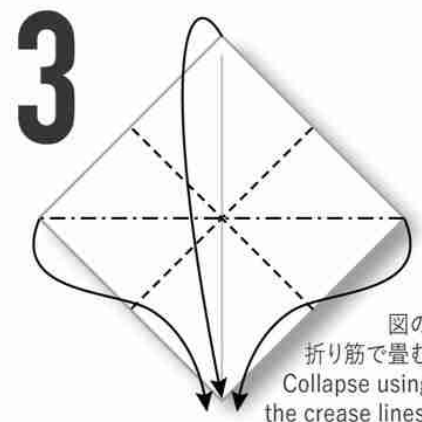
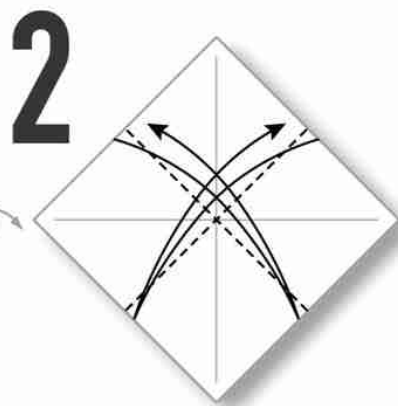
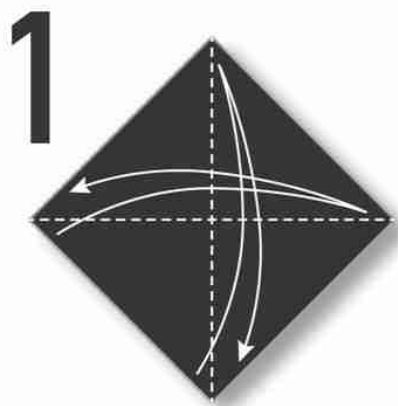
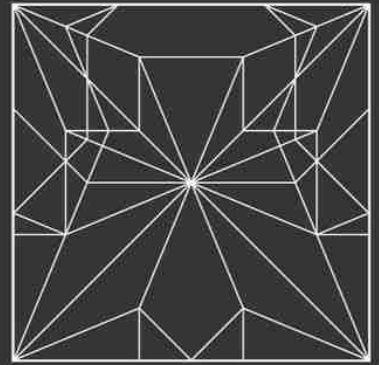

図の折り筋で畳む
Collapse using the crease lines.

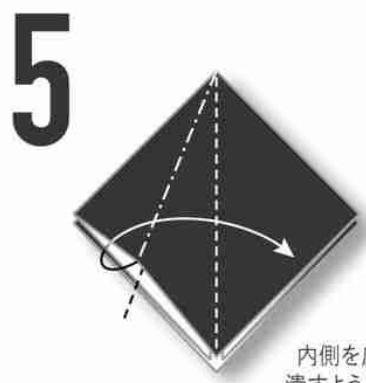
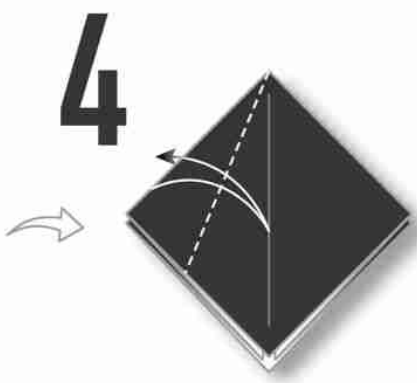

内側を広げて潰すように折る
Open and squash.

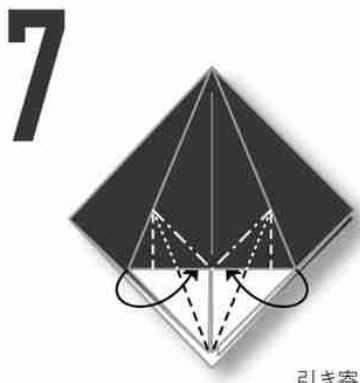
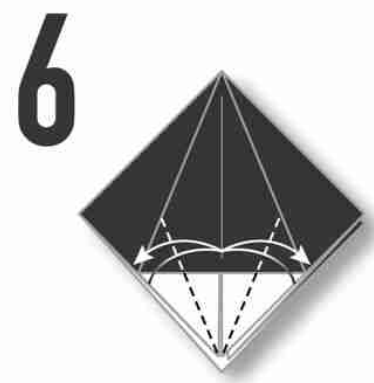

引き寄せ折り
Swivel inside.

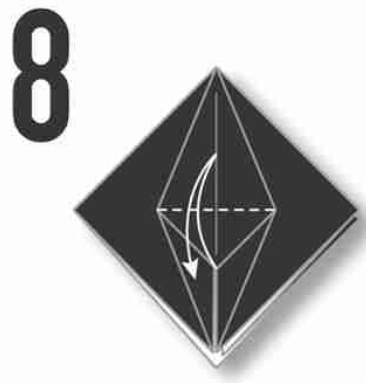

広げて沈め折り
Open sink.

SWALLOW

10



11

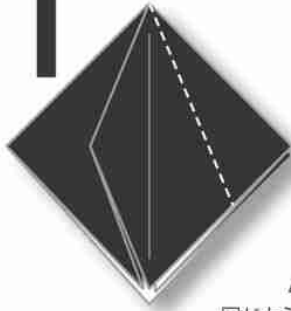

4-10 と
同じように折る
Repeat steps 4-10.

12

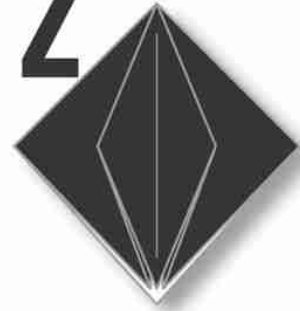

13

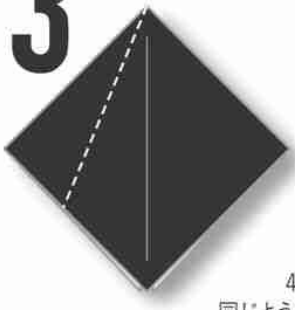

4-10 と
同じように折る
Repeat steps 4-10.

14

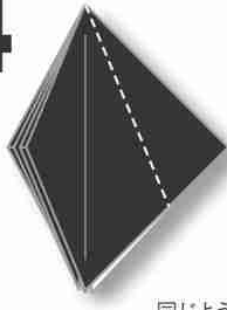

4-7 と
同じように折る
Repeat steps 4-7.

15



16

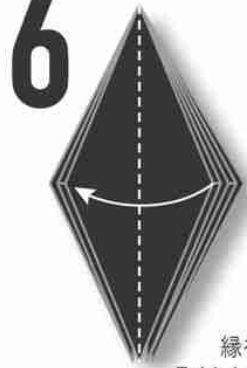

縁を1枚めくる
Fold the top layer.

17

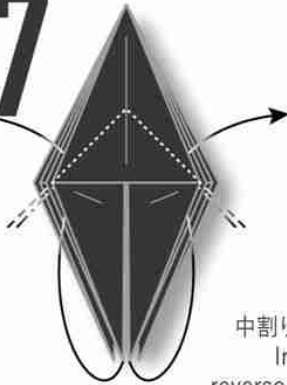

中割り折り
Inside
reverse fold.

18

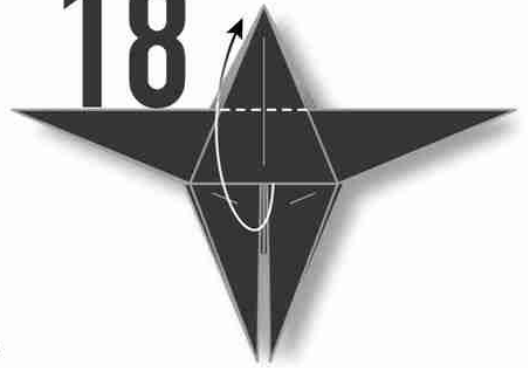

19

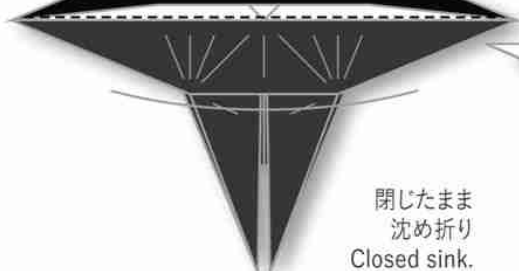

閉じたまま
沈め折り
Closed sink.

20



21



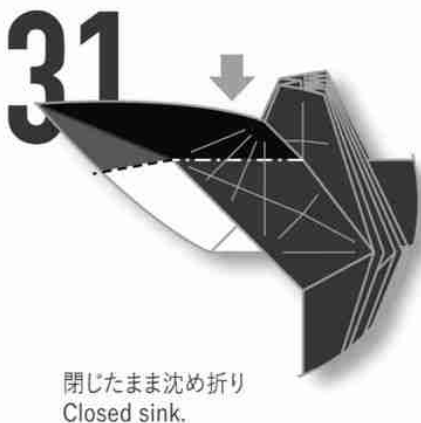
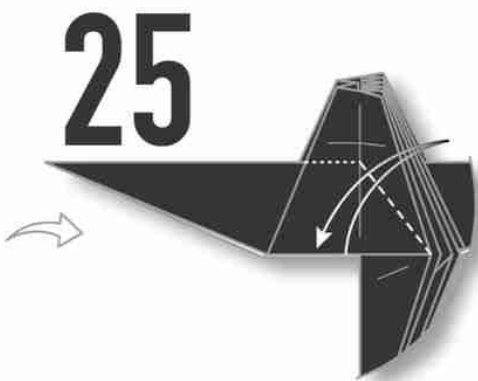

SWALLOW

34

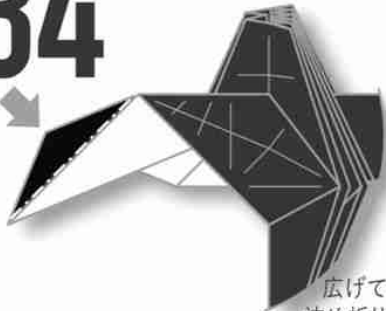

広げて
沈め折り
Open sink.

35

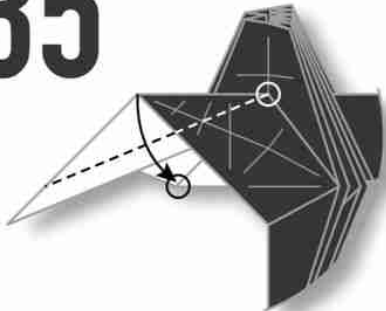

36

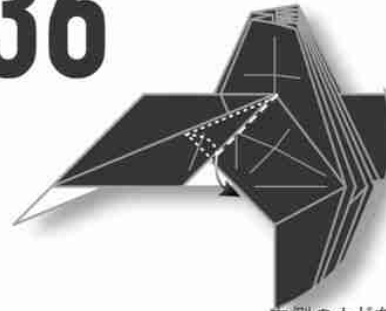

内側のカドを
引き出すように折る
Pull out the inner corner.

37

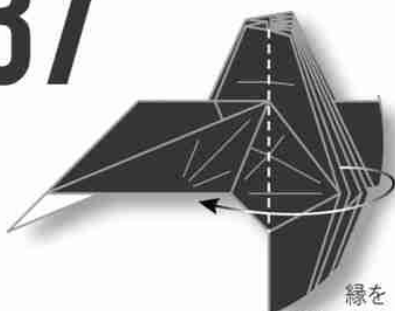

縁を
2枚めくる
Fold the top two layers.

38



反対側も 24-37
と同じように折る
Repeat steps
24-37 on the right.

39



40

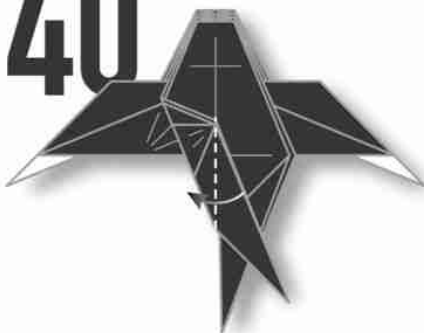

41

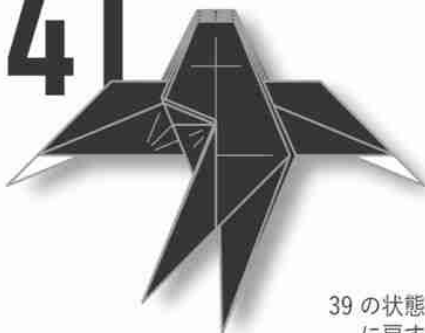

39 の状態
に戻す
Unfold to step 39.

42



両側で
内側に
向かって段折り
Crimp inside.

43



反対側も 39-42
と同じように折る
Repeat steps
39-42 on the right.

44



45

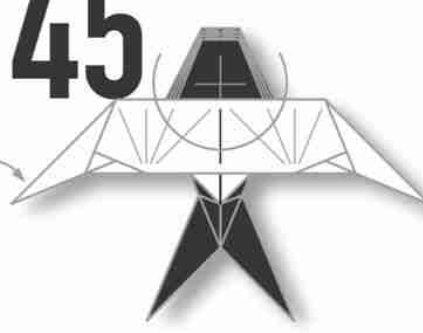

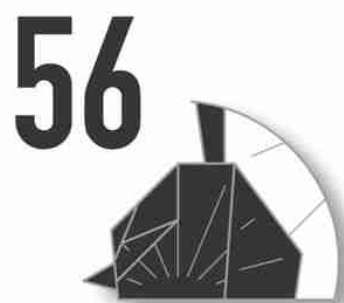
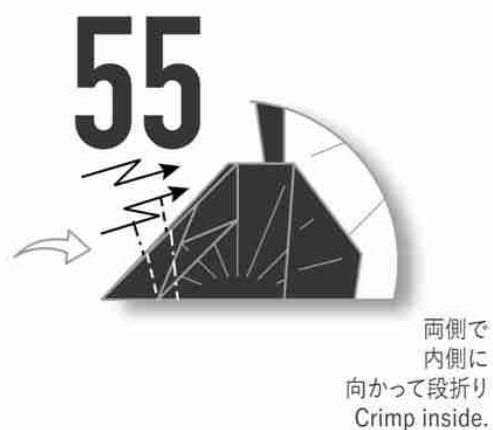
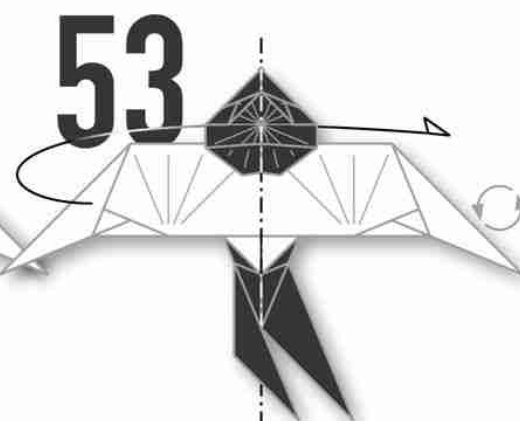
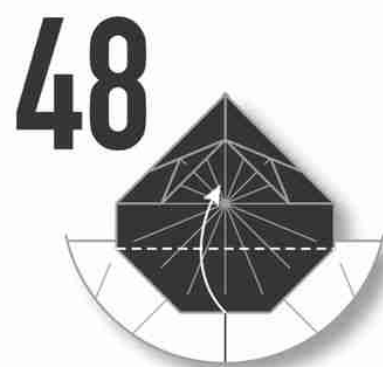
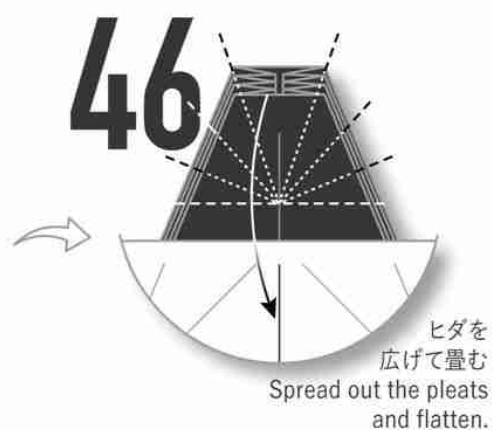

CRESTED KINGFISHER

ORIGAMI MONO

ヤマセミ
2017



2017年におりねっと(全国の大学折り紙サークル団体)の講習用に、キャラクター性を重視しつつシンプルに創作するも、工程数の多さと難易度の関係で採用しなかった作品です。現在私のホームページで折り図を丸々公開していますが、ヤマセミって白黒だよなという気持ち一つで本書に掲載しました。使えるものは使います。

ところで、今更ですが本書は折り図はいかがでしょうか。輪郭線は50%のグレーにしています。ペンギンでは背景色を、今は影の色を同色にすることで、輪郭を見えにくくしています。輪郭が無い方が独特な見え方になるのではないかという思惑です。

This work was created simply for the 2017 Orinet(Unified organization of origami clubs at universities nationwide) class while emphasizing character, but I didn't adopt it due to the number of steps and difficulty. Currently, I publish the diagrams on my website, but I use in this book with the feeling "Crested Kingfisher is black and white". I use what I can use.

By the way, how about the design of the diagrams in this book? The outline is 50% gray. The background color is the same for Penguin, and now the shadow color is the same, making it difficult to see the outline. The thought is it would look more unique without the outlines.

20cm×20cm
INTERMEDIATE

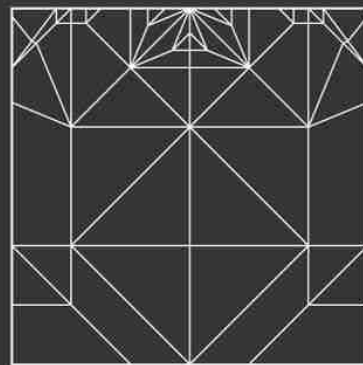

1

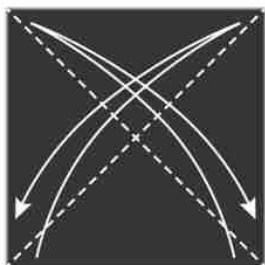

2

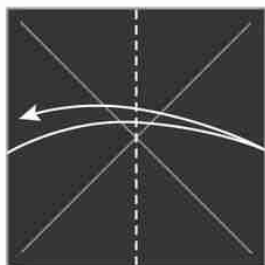

3

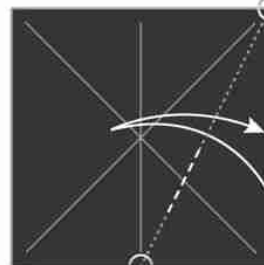

4

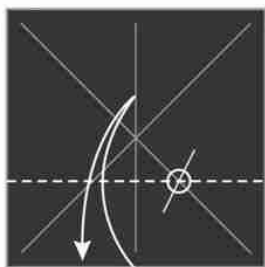

5

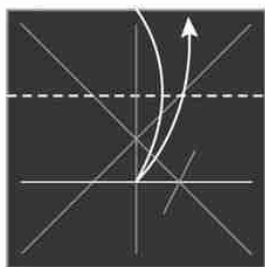

6

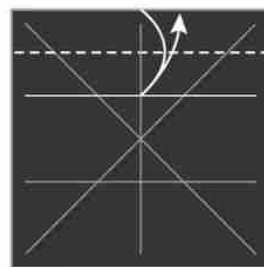

7

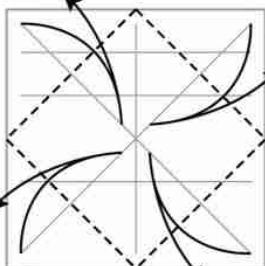

8

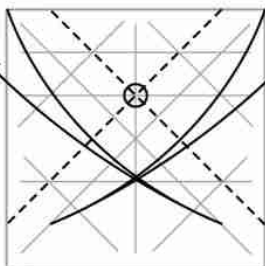

9

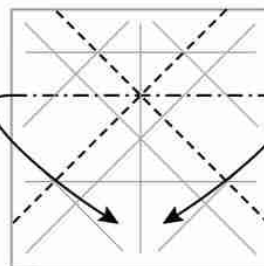

図の折り筋で畳む
Collapse using the crease lines.

CRESTED KINGFISHER

10

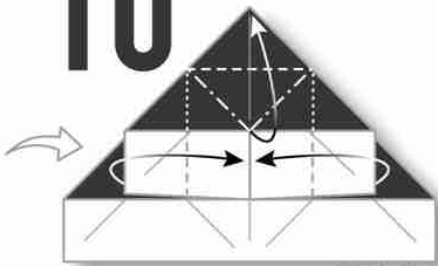

内側を広げて
潰すように折る
Open and squash.

11

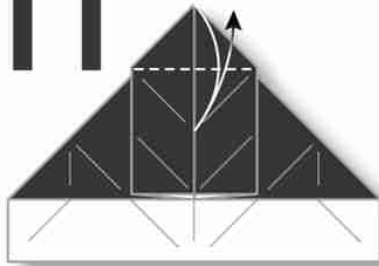

12



内側を広げて潰すように折る
平面にはならない
Open and squash. Not flat.

13



起き上がってきた部分を
倒すように折る
Collapse the edge and flatten.

14

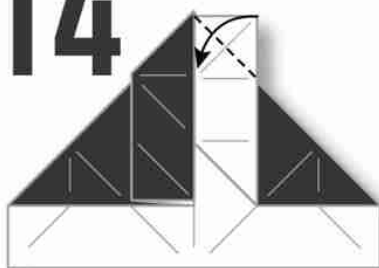

15



反対側も 12-14
と同じように折る
Repeat steps 12-14 on the left.

16

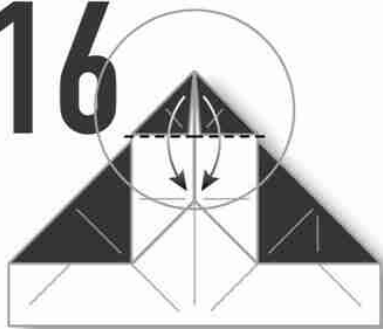

17

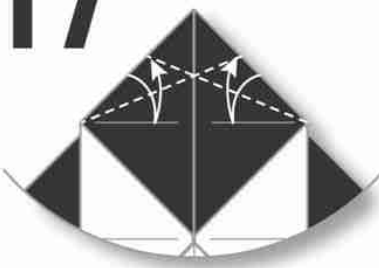

18

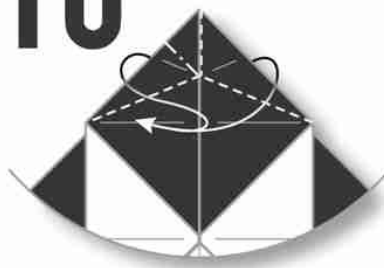

つまむように折る
Rabbit ear fold.

19

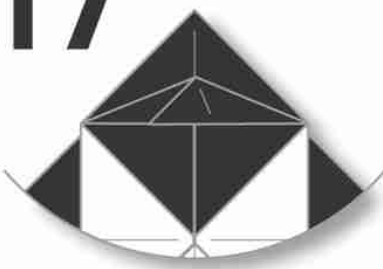

20

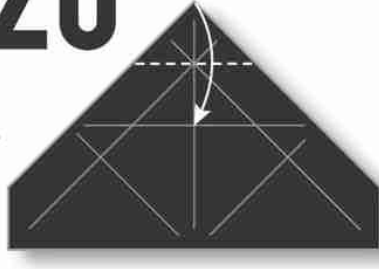

21

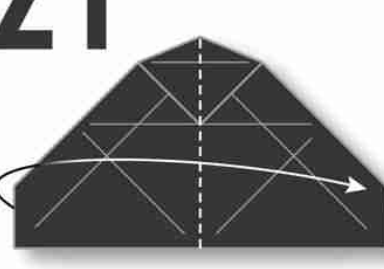

22



23



24



広げて
沈め折り
Open sink.

25

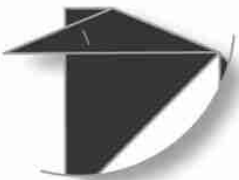

26



27



28

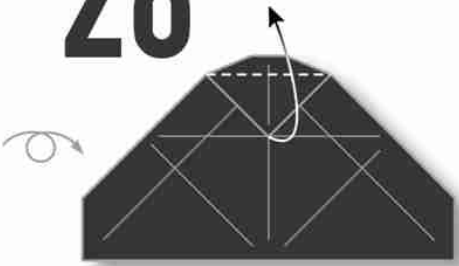

29

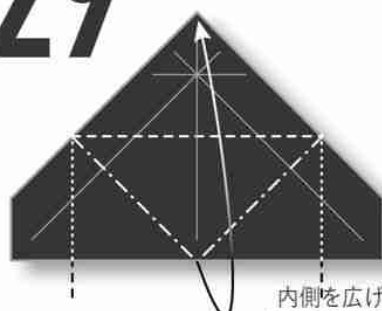

内側を広げて
潰すように折る
Open and squash.

30



31



32



33



CRESTED KINGFISHER

34



上から
2番目の隙間で
内側を広げて潰すように折る

Open and squash at the second pocket.

35



36

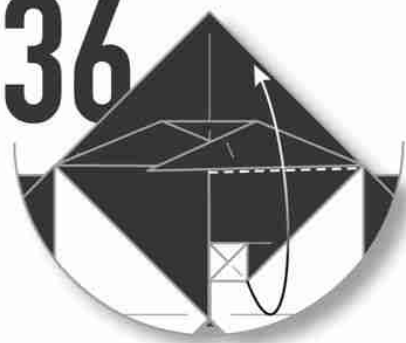

37



38



39



反対側も 32-38
と同じように折る

Repeat steps 32-38 on the left.

40



41

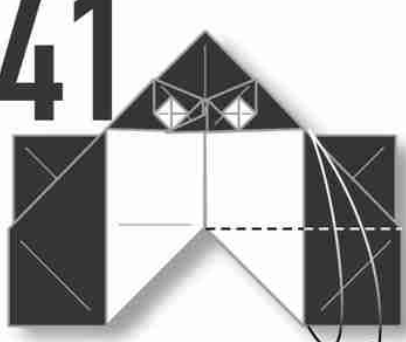

42

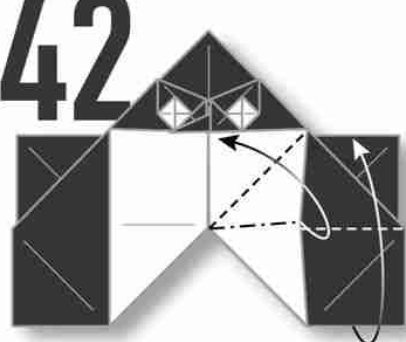

内側を広げて潰すように折る
Open and squash.

43

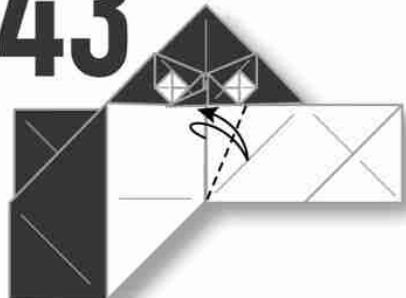

44

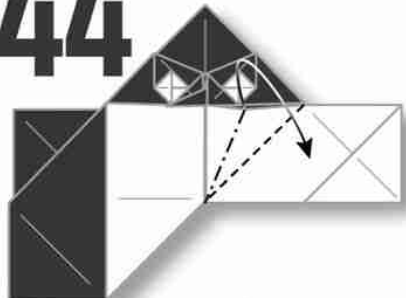

内側を広げて潰すように折る
Open and squash.

45



反対側も 41-44
と同じように折る

Repeat steps 41-44 on the left.

46



47



48



次図を参考に引き寄せ折り
Swivel outside.
Refer to the next step.

49



反対側も 47-48 と同じように折る
Repeat steps 47-48 on the left.

50

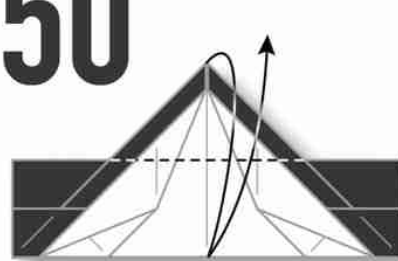

51

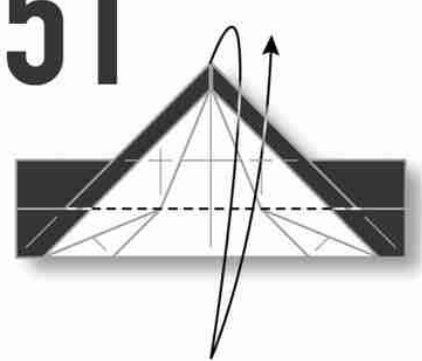

52

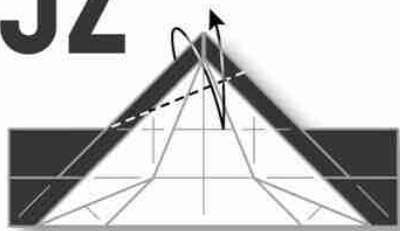

53

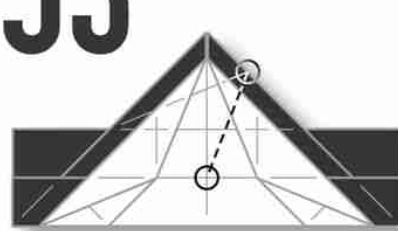

54



手前のカドをつまみながら全体を畳む
Pinch the top corner and fold in half.

55

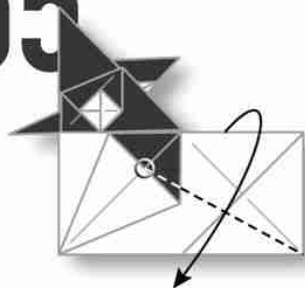

56

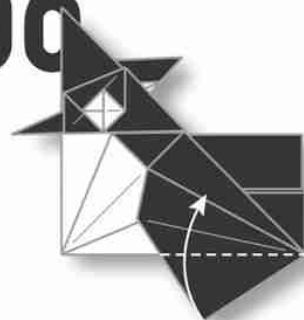

57

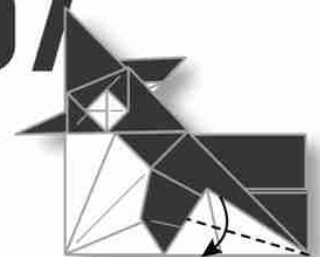

58



反対側も 55-57
と同じように折る
Repeat steps 55-57 behind.

59

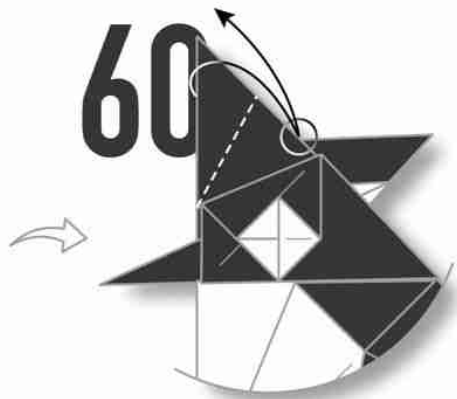

61

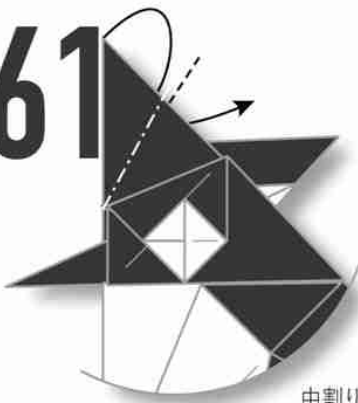

中割り折り
Inside reverse fold.

62

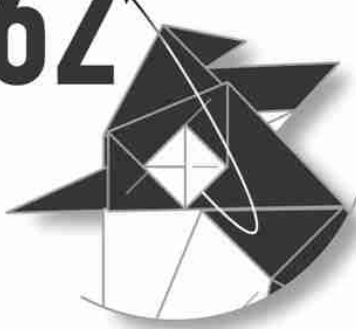

63

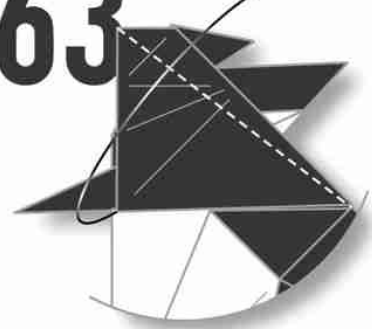

64

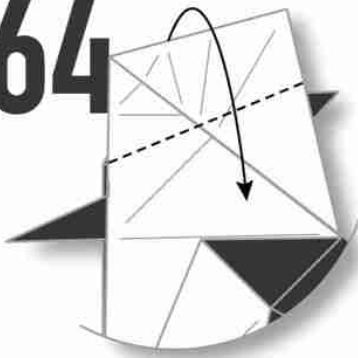

65

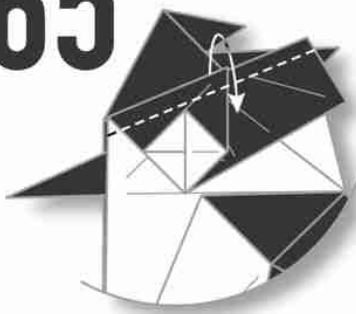

66



反対側も
62-65と
同じように折る
Repeat steps 62-65 behind.

67



68

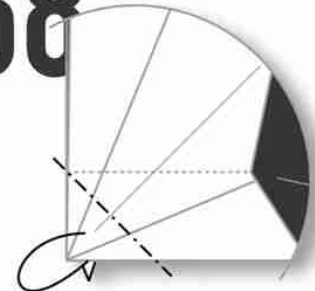

手前の縁を山折り
Fold the top corner.

69

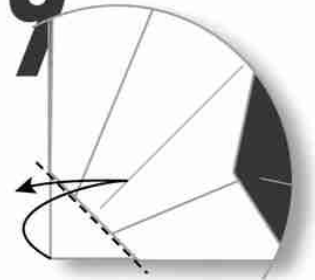

70

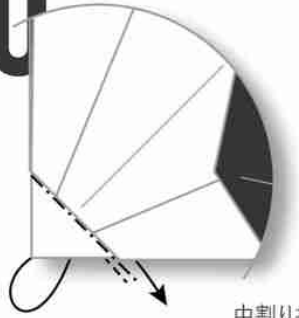

中割り折り
Inside reverse fold.

71

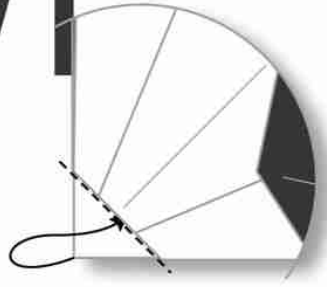

72

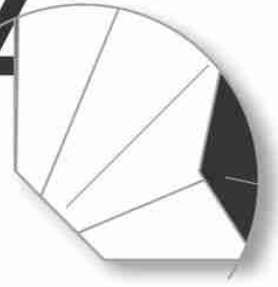

73

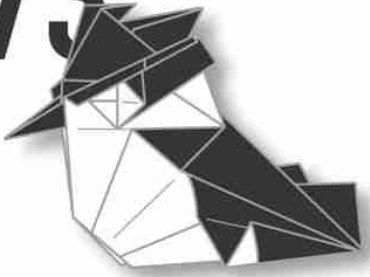

完成
Model completed.

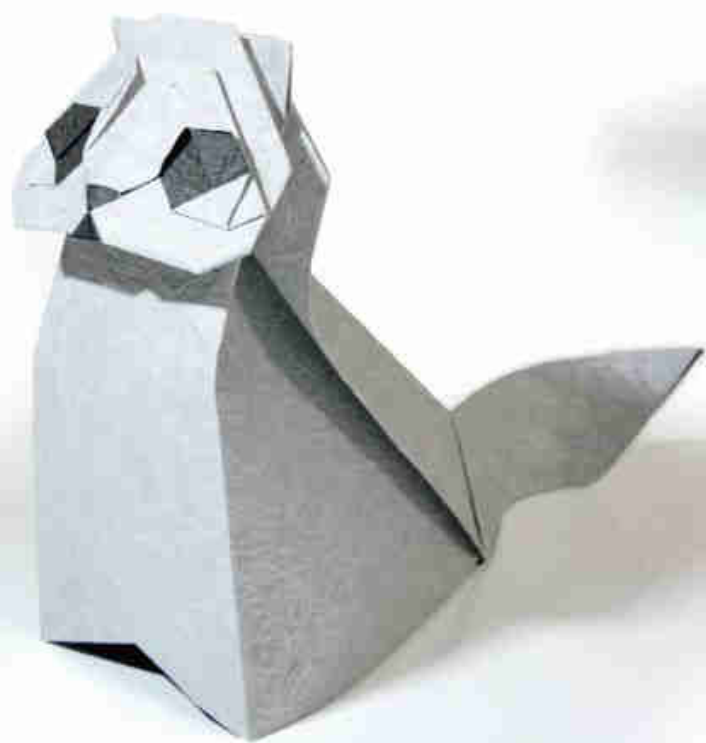

座る猫です。もはや白黒関係ないよねと思われそうですが、白猫なのでOKです。

この作品は、2021年の東京コンベンション用に創作しました。最後の立体化は留めることができませんので、糊付けが必須となります。目元の紙も開きがちですので、糊付けをして可愛く仕上げてください。

折り図デザインの話ですが、白と黒の面を跨ぐ矢印の線色にはグラデーションを使っています。正直最初は、折り図のデザインテンプレートを変えるぐらい簡単でしょ、一括選択の機能もあるし、と舐めていました。しかし、線色のグラデーション等、個別の作業が多くかなり時間がかかりました。

You might think that it's not related to B&W anymore, but it's OK because it's a white cat.

This work was created for the 2021 Tokyo Convention. The final model cannot be locked, so gluing is essential. The paper around the eyes also tends to open, so please glue it to make it look cute.

About design of diagrams, I used a gradation for the line color of the arrow that straddles the white and black surfaces. At first, I made light, "It would be easy changing the design template of the diagrams. There is also a function of batch selection." However, it took a lot of time to do each work such as line color gradation.

20cm×20cm
INTERMEDIATE

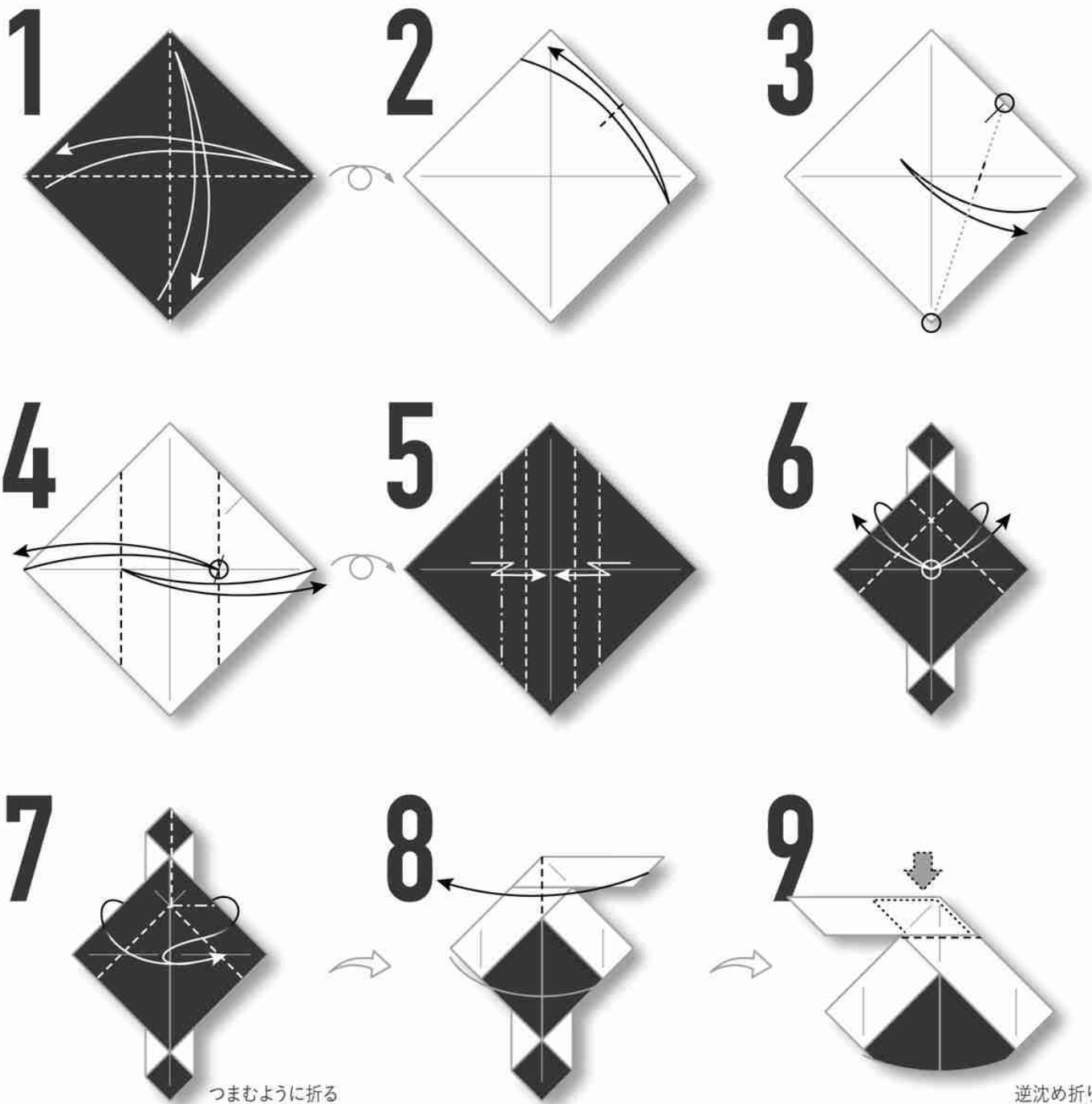
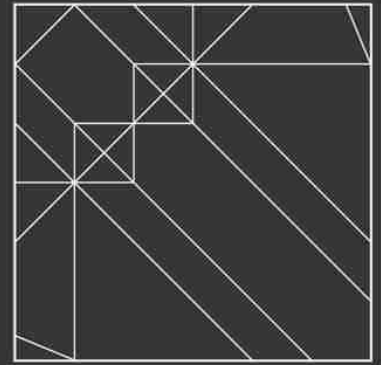

つまむように折る
Rabbit ear fold.

逆沈め折り
Unsink.

SIT-CAT

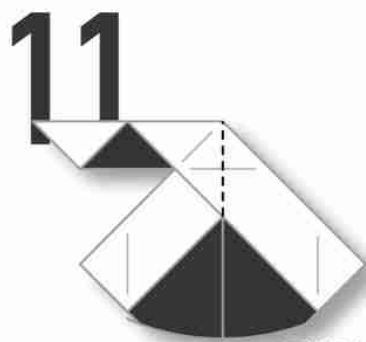
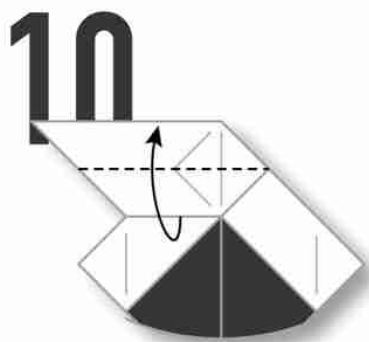

反対側も 8-10
と同じように折る
Repeat steps 8-10.

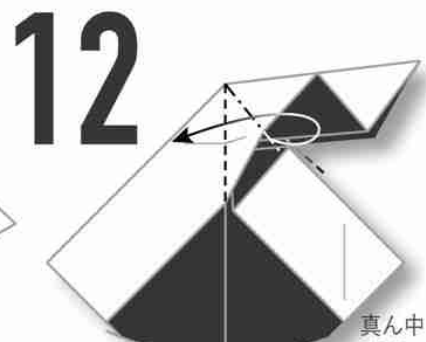

真ん中
の隙間で
内側を広げて潰すように折る
Open and squash at the middle pocket.

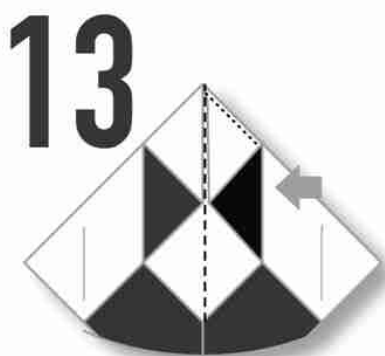

逆沈め折り
Unsink.

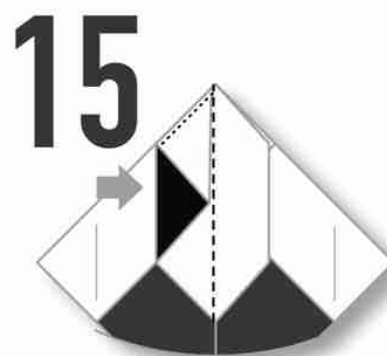
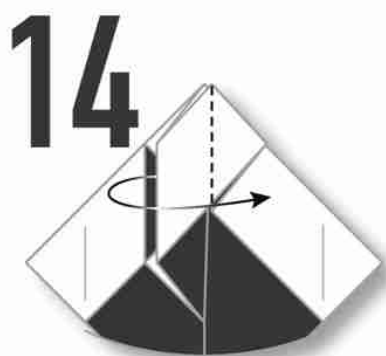

逆沈め折り
Unsink.

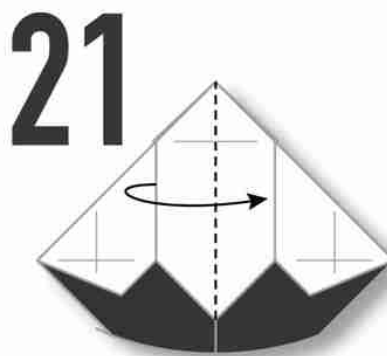
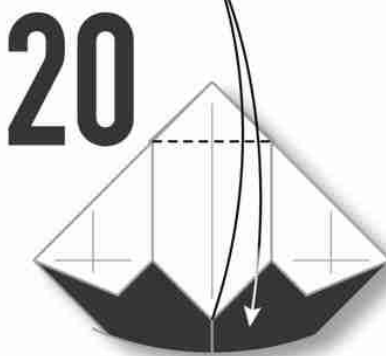
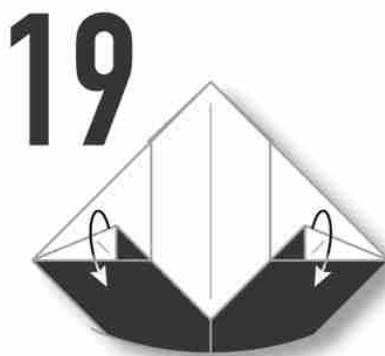
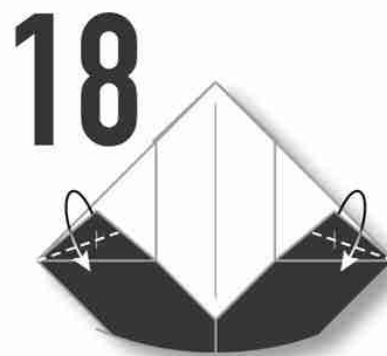
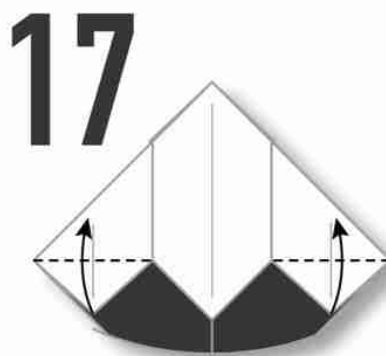
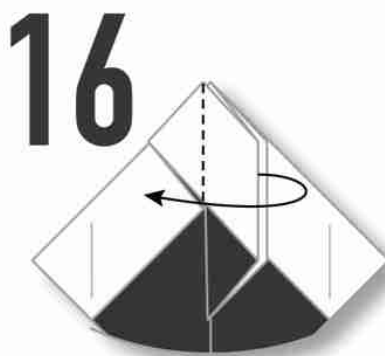

22

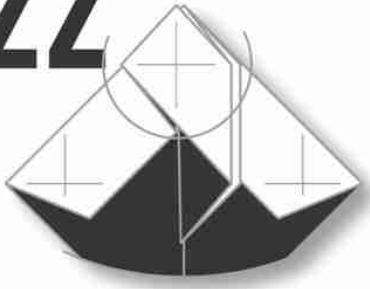

23

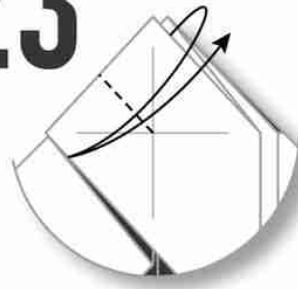

24



手前のカドをつまみながら全体を畳む
Pinch the top corner and fold the layer.

25



反対側も 21-24 と同じように折る
Repeat steps 21-24 on the right.

26

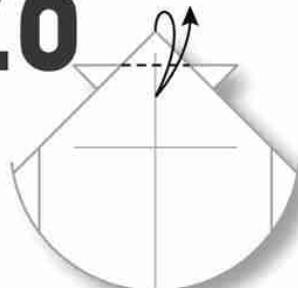

27

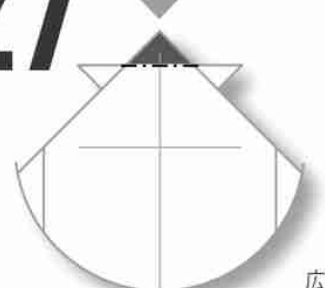

広げて沈め折り
Open sink.

28

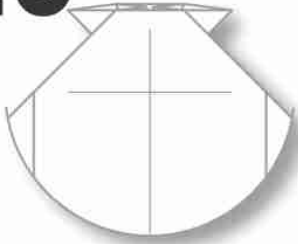

29



30

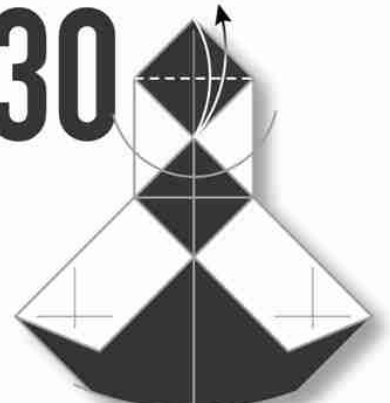

31

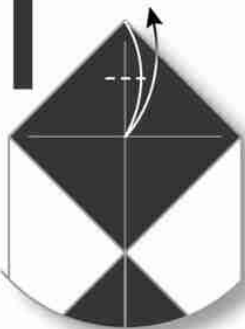

32

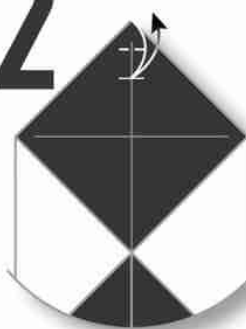

33

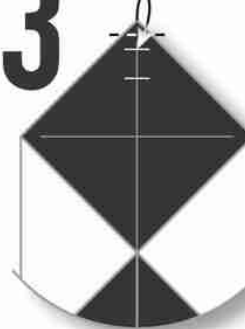

SIT-CAT

34

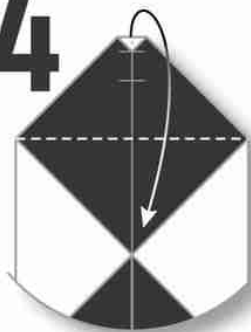

35

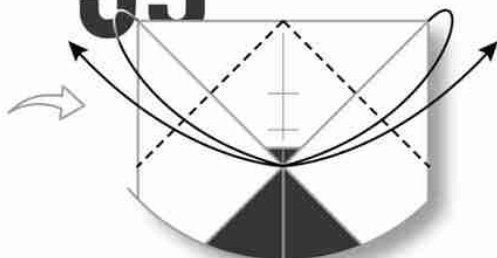

36

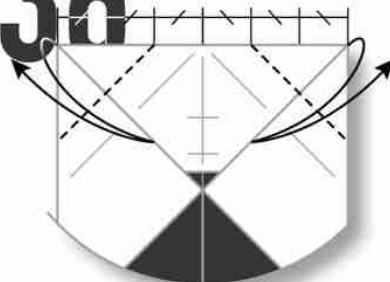

37

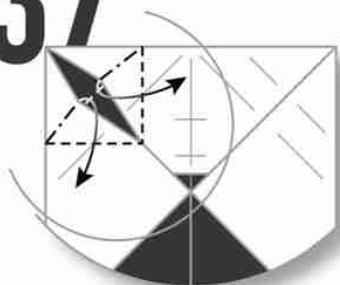

38

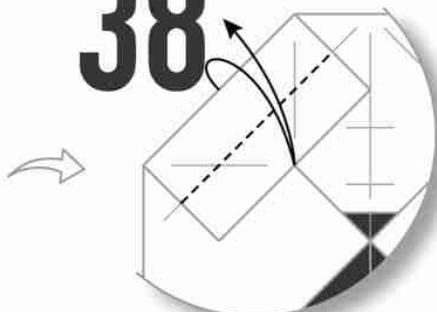

39

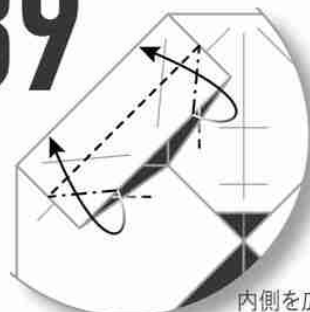

内側を広げて
潰すように折る
Open and squash.

40



引き寄せ折り
Swivel fold.

41

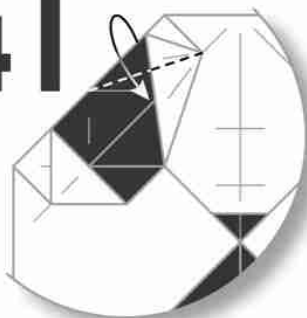

42



反対側も 37-41
と同じように折る
Repeat steps 37-41 on the right.

43



44

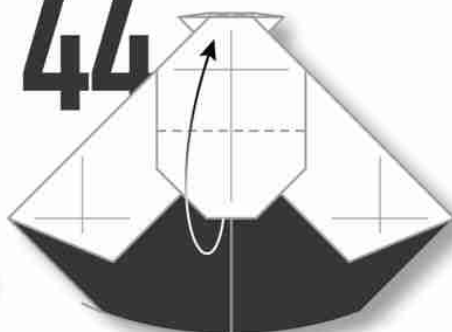

図のような位置で折る
Fold the layer as shown.

45

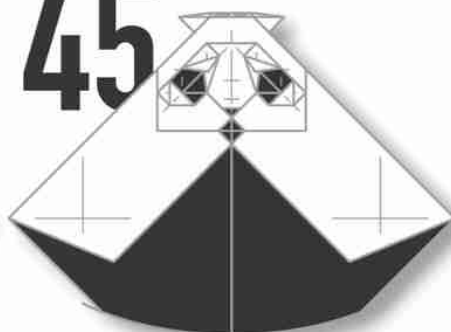

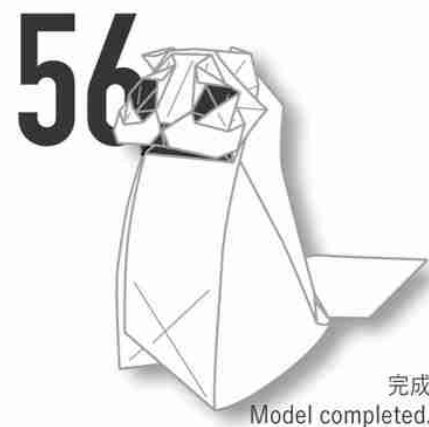
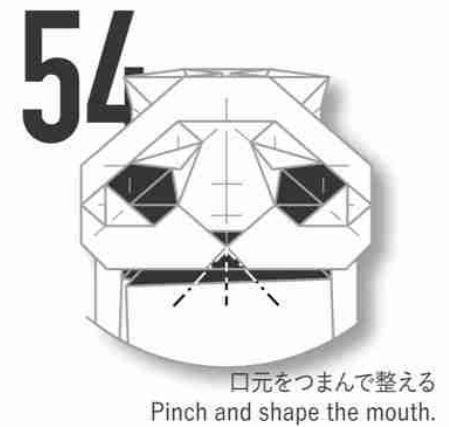
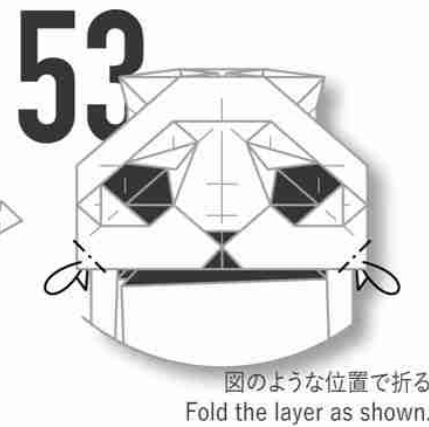
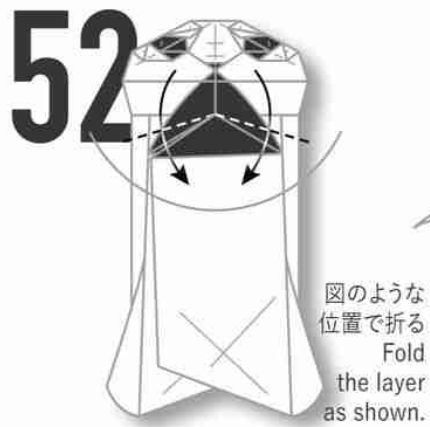
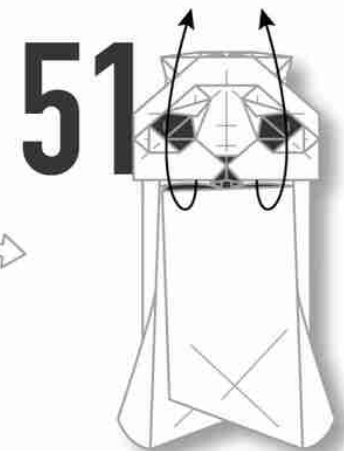
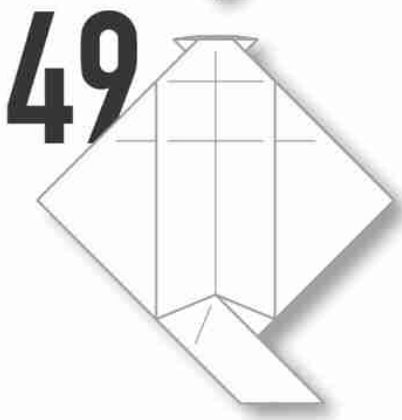
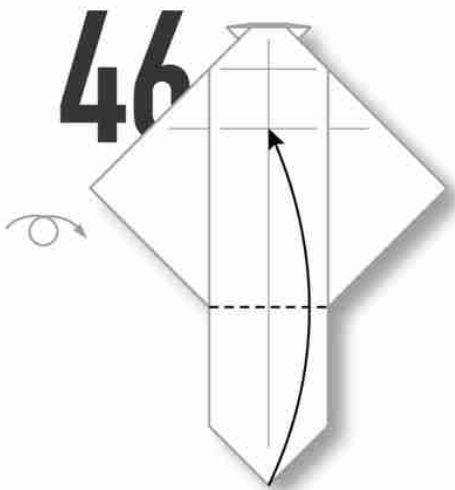

POLAR BEAR

ORIGAMI MONO

シロクマ
2022

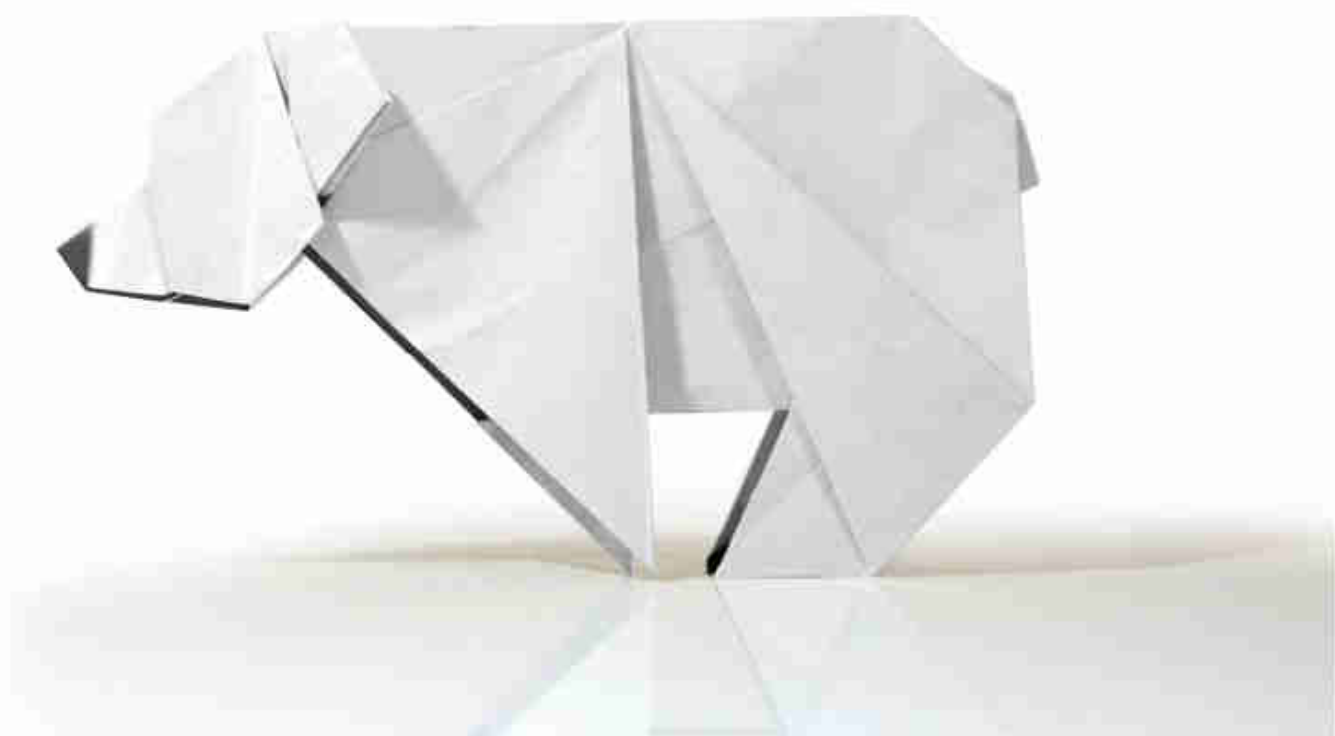

私の中で黒と言えばカラス、白といえばシロクマという気持ちがあります。特に、「シロクマは実は体毛が半透明で、地肌の色は黒い」という話を聞いた時から、白黒から連想する動物の中でも上位になりました。少なくともペンギンよりは上になりました。そういう意味で、この本には必須のモチーフでした。ただ当たり前かもしれませんが、色を変えれば普通のクマになります。

折り図の黒い面は90%グレーで、若干目に優しい黒に統一しています。影は図の線幅を1ptにして10pixelのぼかしを入れています。これのおかげで、随分とIllustratorの動作が重くなったように感じます。

In my mind, black is associated with crows, and white is associated with polar bears. In particular, when I heard that "polar bears actually have translucent body hair and black skin," they ranked high among the animals associated with black and white. At least above the penguins. It may be obvious, but if you change the paper color, it will become a normal bear.

The black side of the diagram is 90% gray, which is kind to the eyes. For shadows, the line width is set to 1pt and a blur of 10 pixels is added. Thanks to this, I feel that the operation of Illustrator has become much slower.

20cm×20cm
INTERMEDIATE

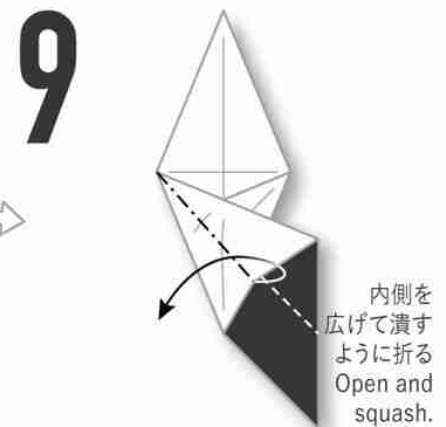
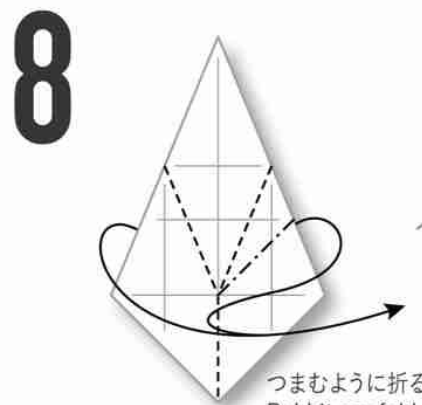
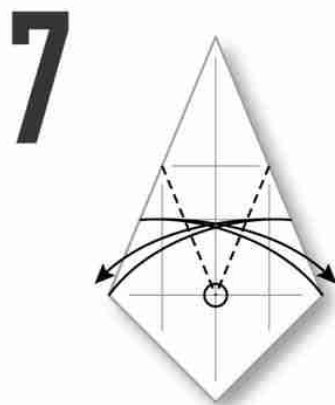
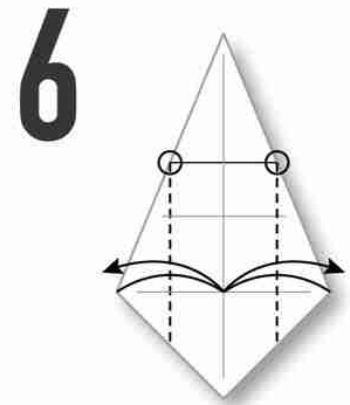
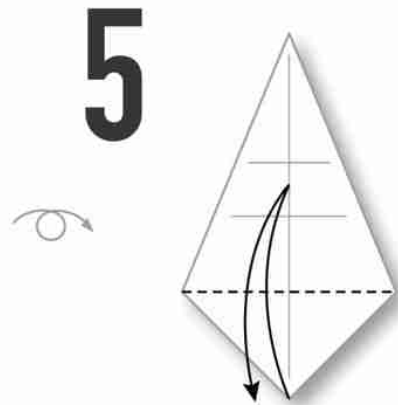
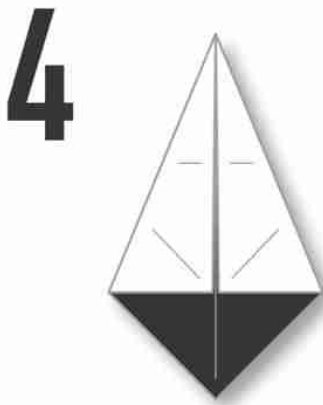
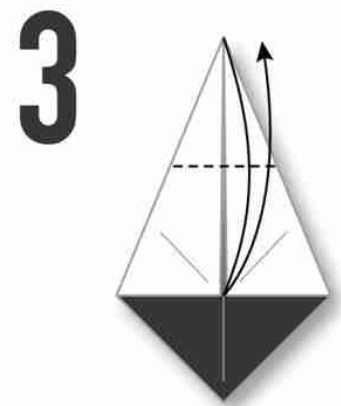
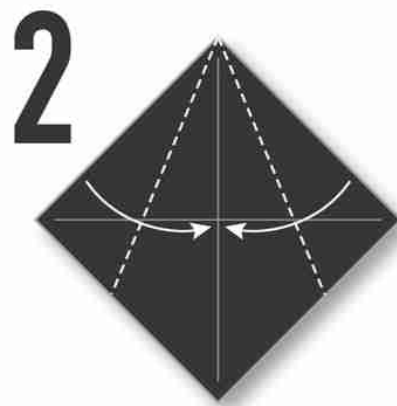
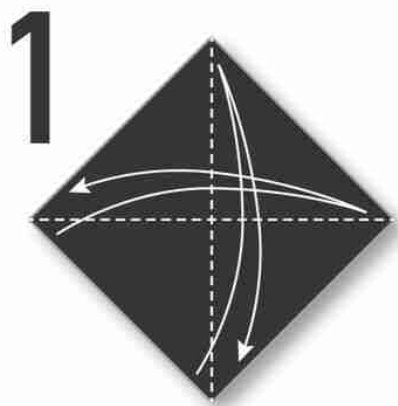
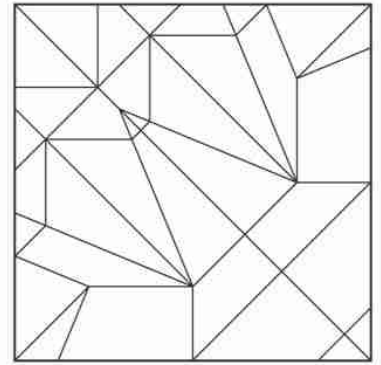

POLAR BEAR

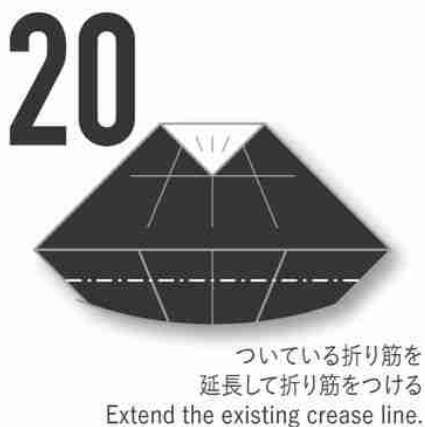
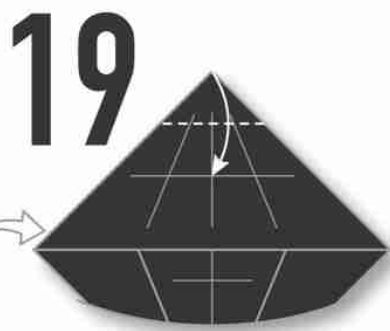
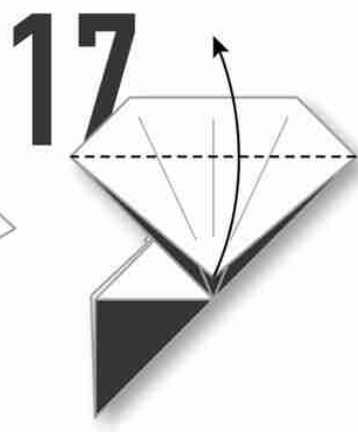
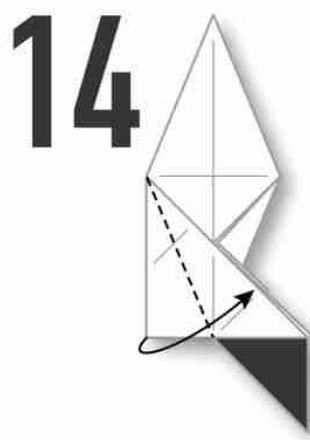
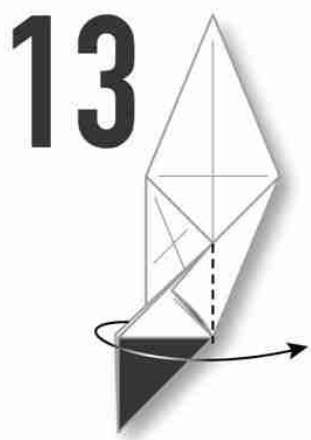
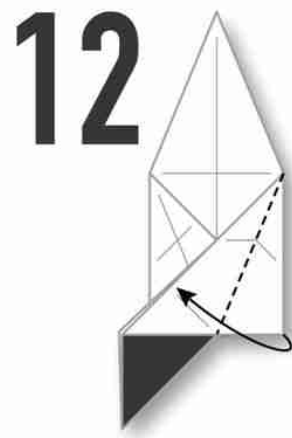
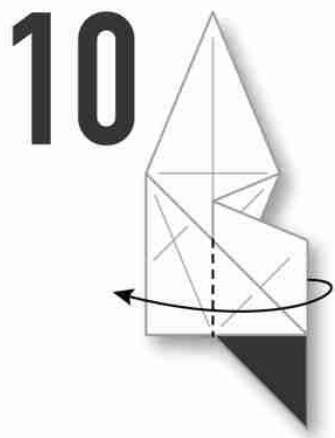

22

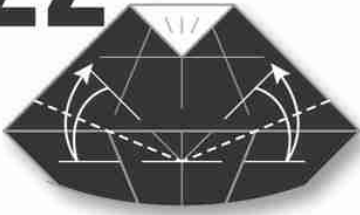

23

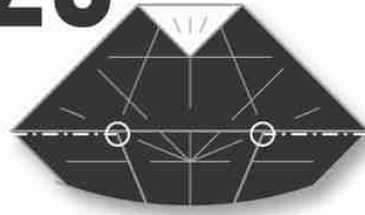

24

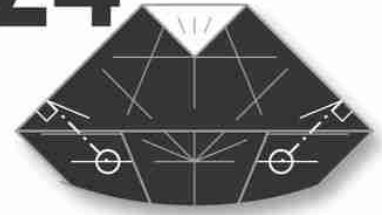

25



26

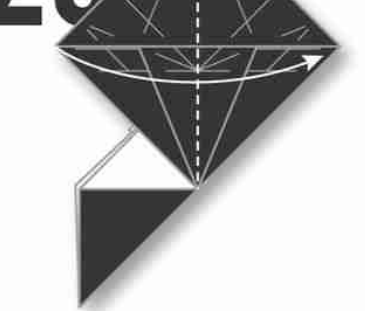

27

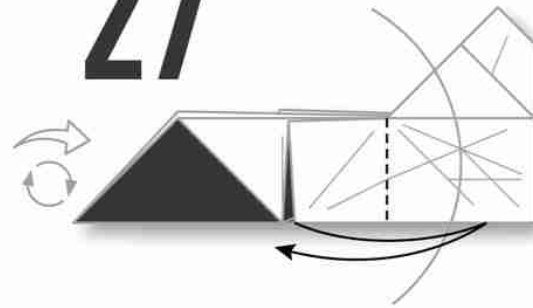

28

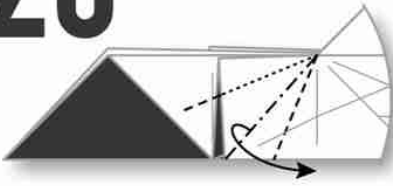

引き寄せ折り
Swivel outside.

29

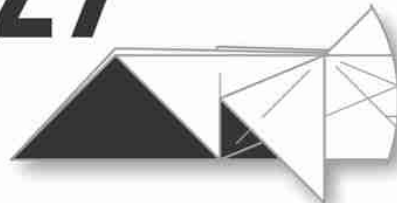

反対側も 27-28
と同じように折る
Repeat steps
27-28 behind.

30

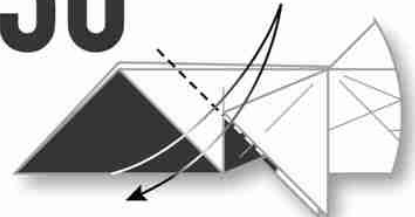

31

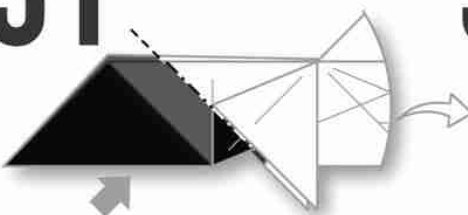

閉じたまま
沈め折り
Closed sink.

32



33

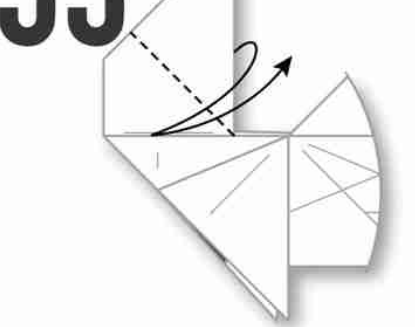

POLAR BEAR

34

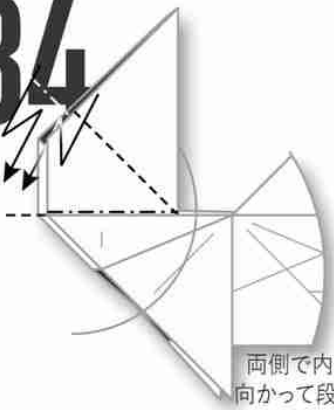

両側で内側に向かって段折り
Crimp inside.

35

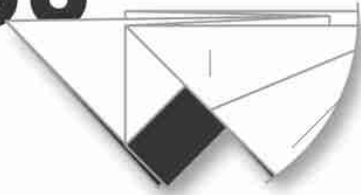

36

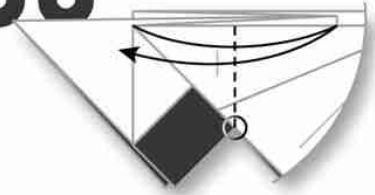

37

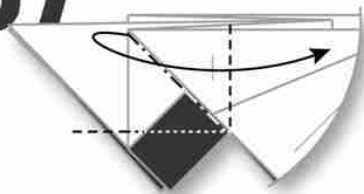

内側を広げて潰すように折る
Open and squash.

38

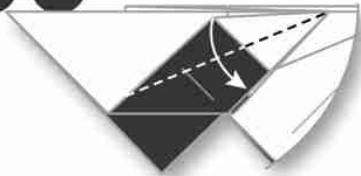

39

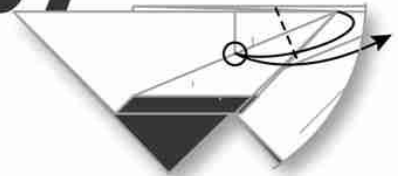

40

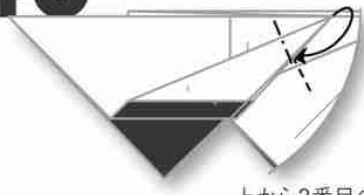

上から2番目の隙間で中割り折り
Inside reverse fold at the second pocket.

41

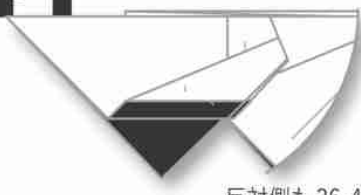

反対側も 36-40 と同じように折る
Repeat steps 36-40 behind.

42

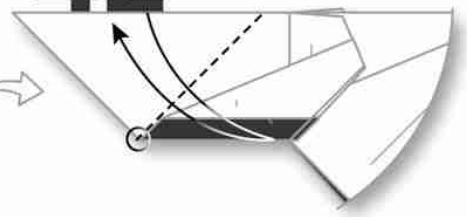

43

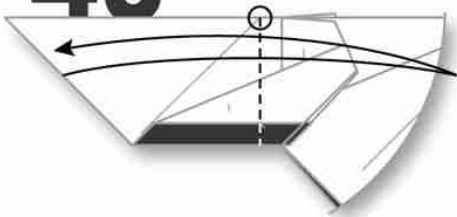

44

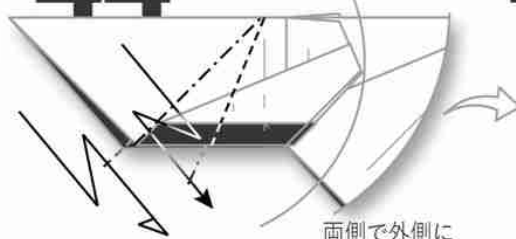

両側で外側に向かって段折り
Crimp outside.

45

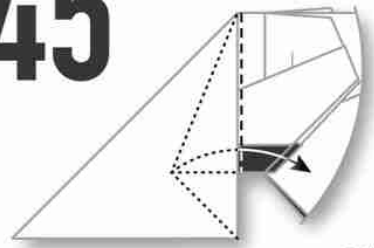

内側のカドを引き出す
Pull out the inner corner.

46



縁をめくって裏返す
Reverse the paper
wrapping the corner.

47



反対側も 45-46
と同じように折る
Repeat steps
45-46 behind.

48

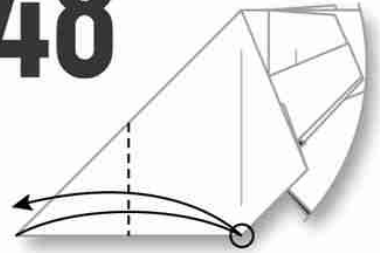

49

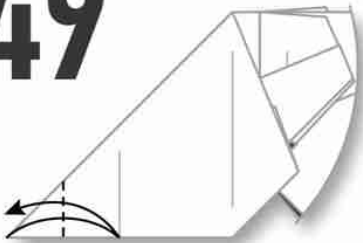

50

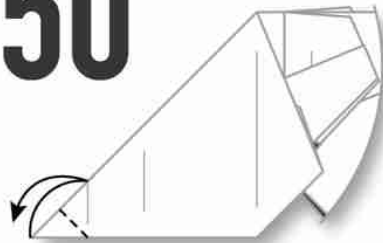

51

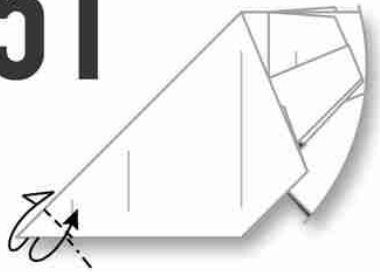

52



53

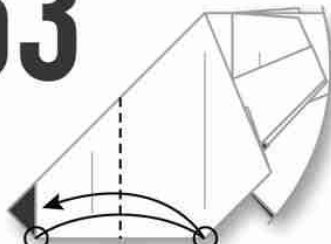

54

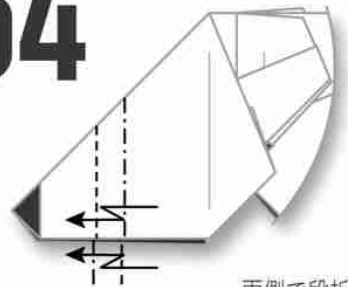

両側で段折り
Pleat on
both sides.

55

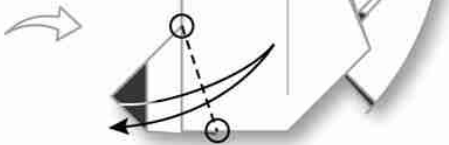

56

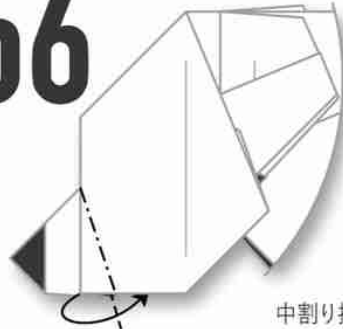

中割り折り
Inside
reverse fold.

57



反対側も 54-55
と同じように折る
Repeat steps 54-55
behind.

POLAR BEAR

58

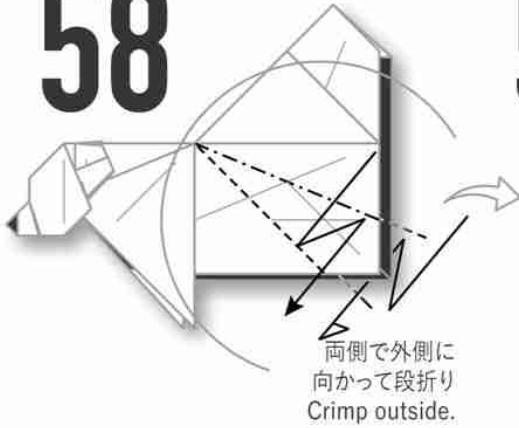

59

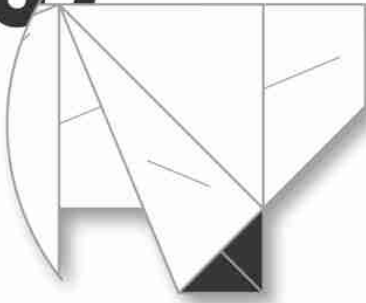

60

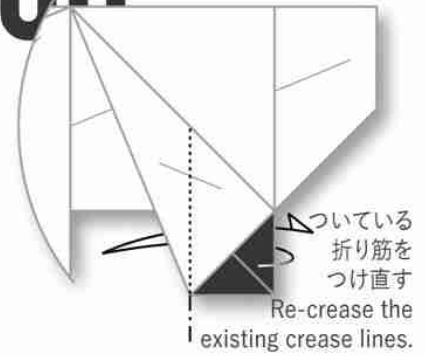

61

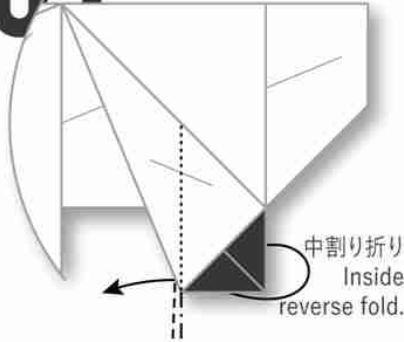

62

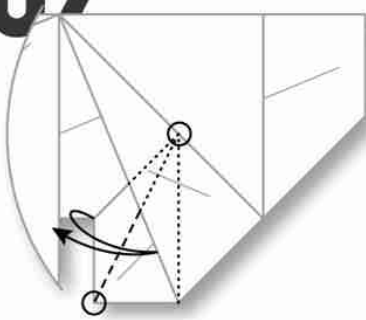

63

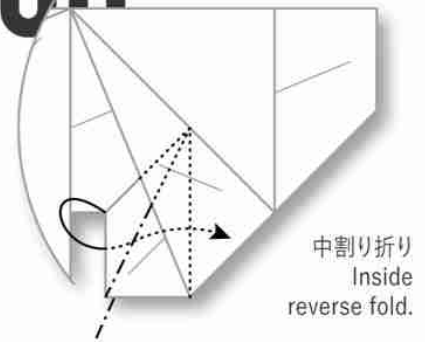

64

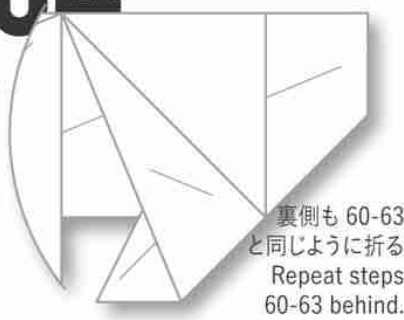

65

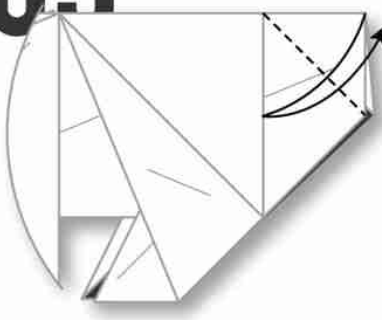

66

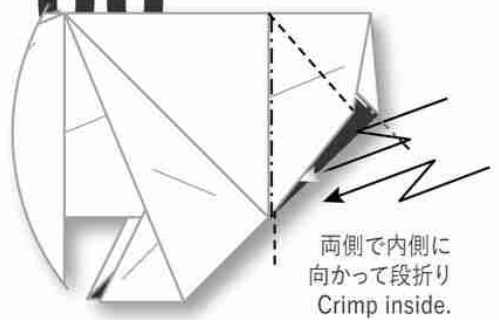

67

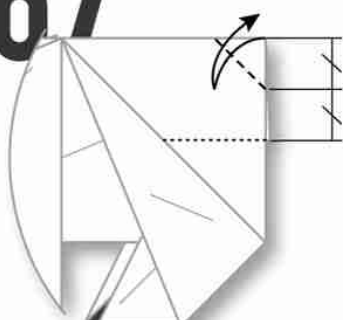

68

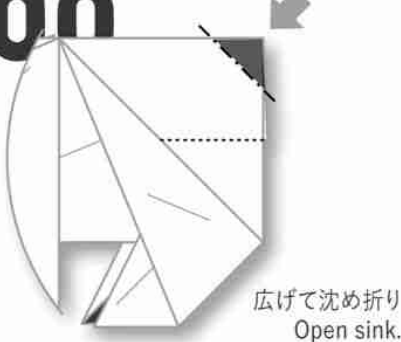

69

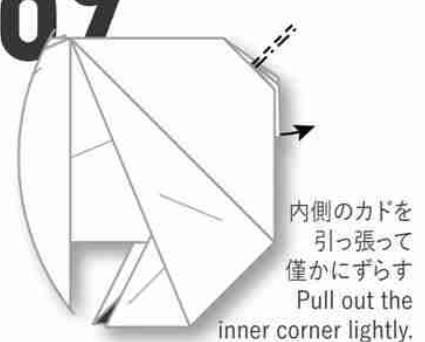

70



71

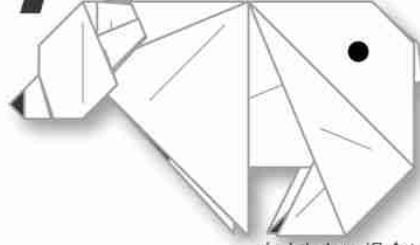

自立しない場合は
●部分に重りを入れる
If the model does not stand on its own,
put a weight in the circled point.

72

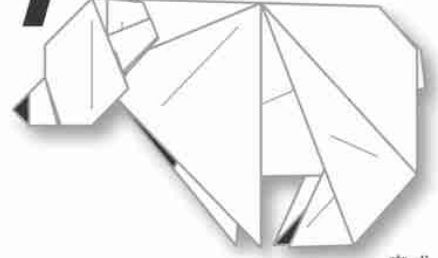

完成
Model completed.

LONG-TAILED TIT

ORIGAMI MONO

シマエナガ
2022



かわいい生き物の代表格、どう見ても名前にすべきモフモフボディに対し、不運にも尻尾をメイン採用されてしまった大福こと、シマエナガです。

この作品の長所は、足の指の表現が珍しいところです。カドを独立させずに、仕上げで3本あるように見せかけています。この作品の短所は、足の指が足りないところです。実物は指が4本あります。

折り図の話が続いていましたが、再現を勧めている訳ではありません。寧ろ他で使うと迷惑が掛かるのでやめましょう。既にお気づきかもしれませんが、折り図デザインの話をしている時は話のネタが無い時です。

Unfortunately, this animal is adopted the tail as the main name in Japanese, as opposed to the fluffy body that should be named. It is cute and resembles Daifuku.

The advantage of this work is that the expression of the toes is unusual. It looks like there are 3 toes without making the corners independent. The disadvantage of this work is not enough toes. The real thing has 4 toes.

Though the story of diagrams was continued, I don't recommend imitation. Rather, it'll cause trouble if you use it elsewhere. As you may have already noticed, when I talk about diagrams, I have nothing else to talk about.

24cm×24cm
INTERMEDIATE

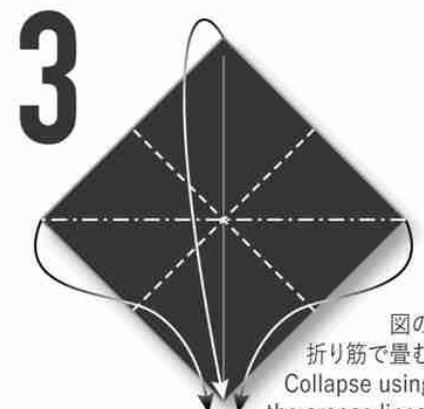
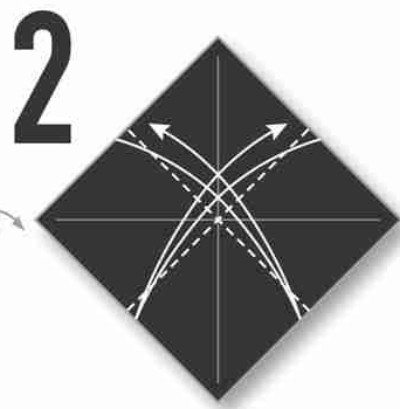
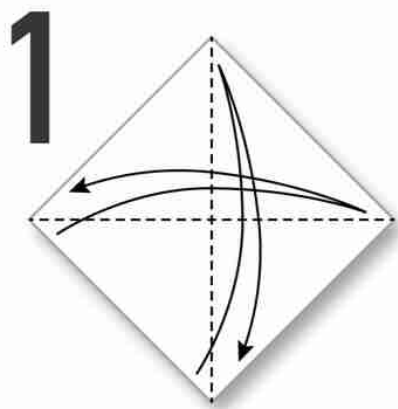
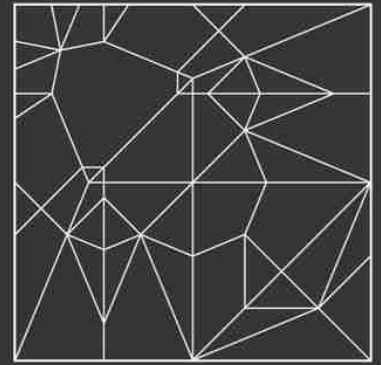

図の
折り筋で畳む
Collapse using
the crease lines.

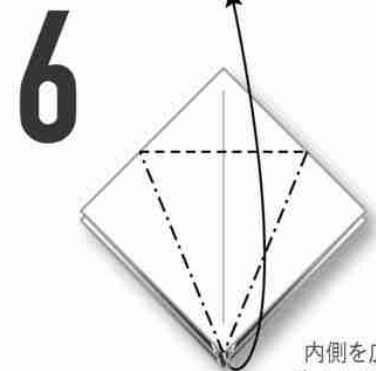
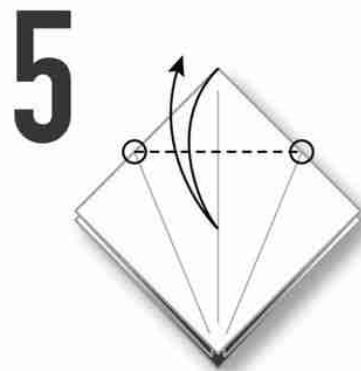
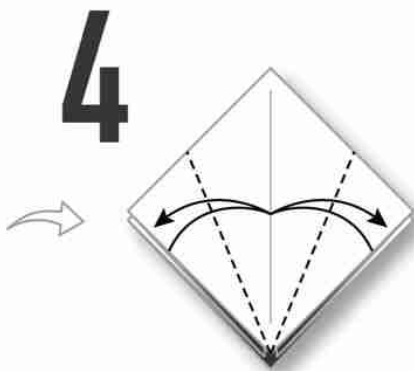

内側を広げて
潰すように折る
Open and squash.

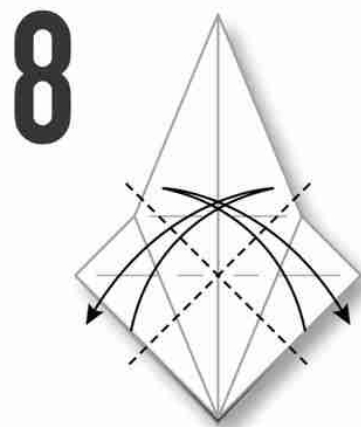
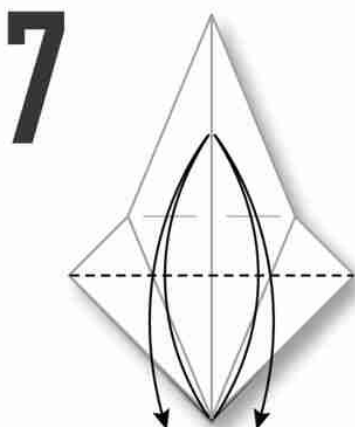

中割り折り
Inside
reverse fold.

LONG-TAILED TIT

10

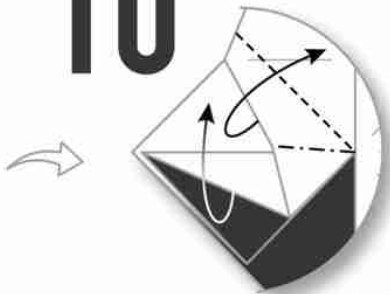

引き寄せ折り
Swivel outside.

11

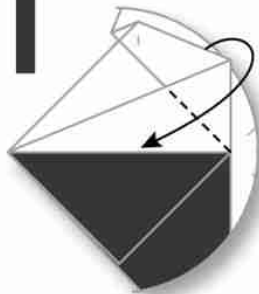

12



閉じたまま
沈め折り
Closed sink.

13



14

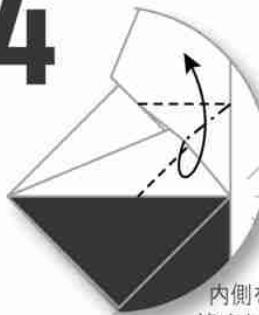

内側を広げて
潰すように折る
Open and squash.

15

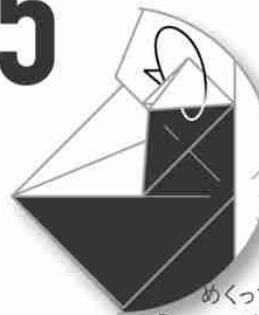

縁を
めくって裏返す
Reverse the paper
wrapping the corner.

16



17



反対側も
9-16と
同じように折る
Repeat steps 9-16 on the right.

18

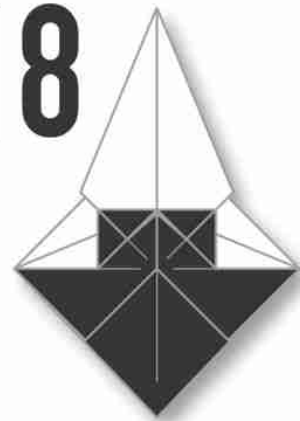

19

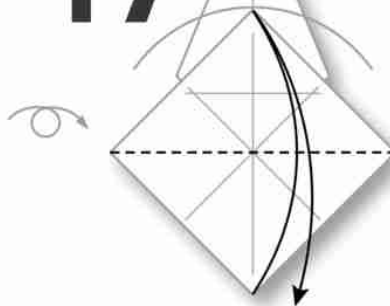

20

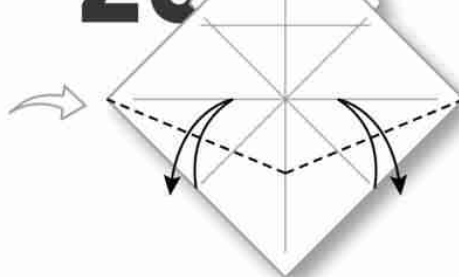

21

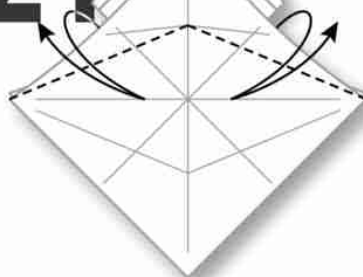

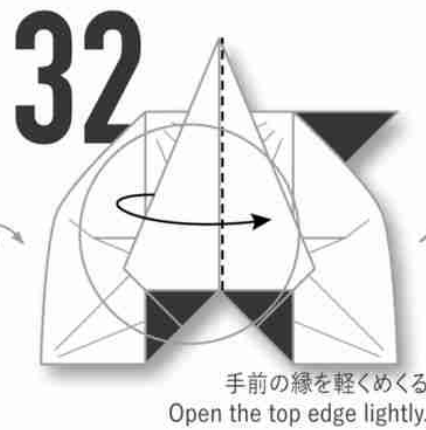
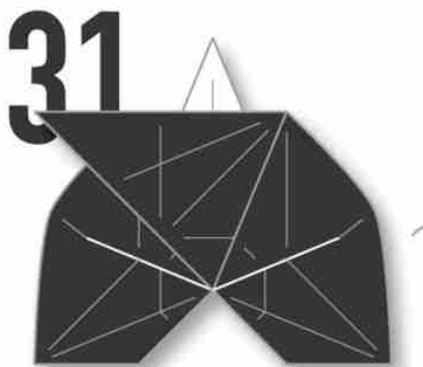
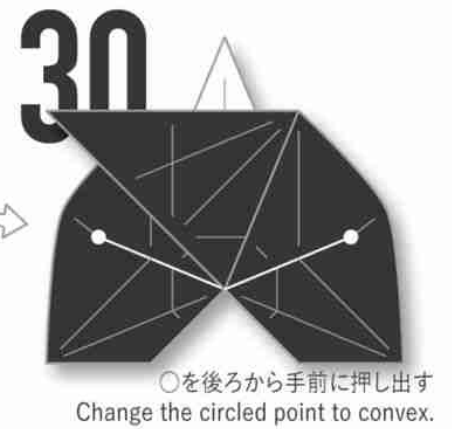
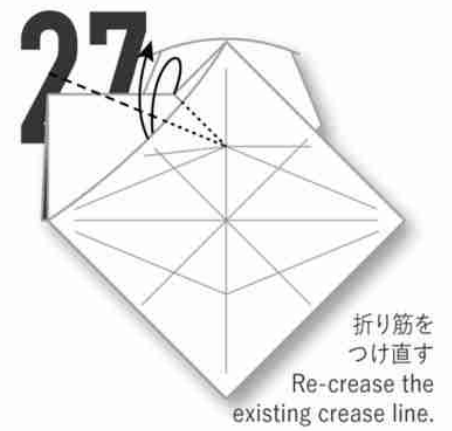

LONG-TAILED TIT

34

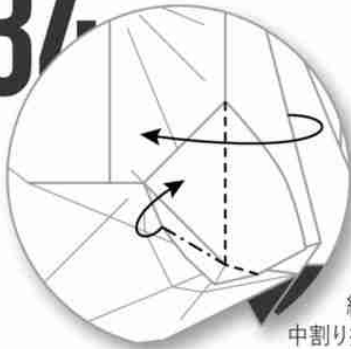

縁を
中割り折り
しながらめくった縁を戻す
Inside reverse fold and close.

35

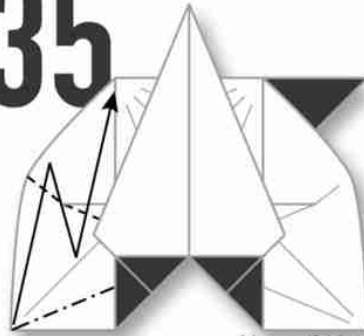

斜めに段折りして
平面に畳む
Pleat an angle and flatten.

36

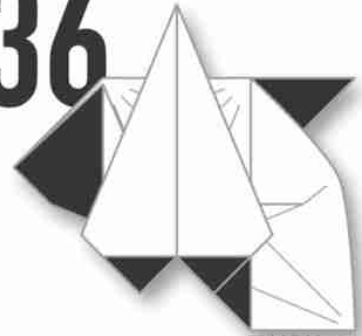

反対側も 32-35
と同じように折る
Repeat steps 32-35 on the right.

37

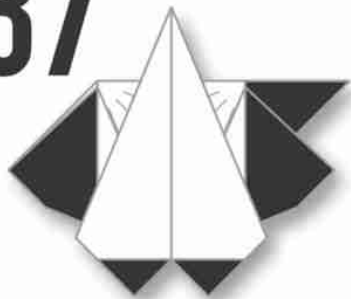

38

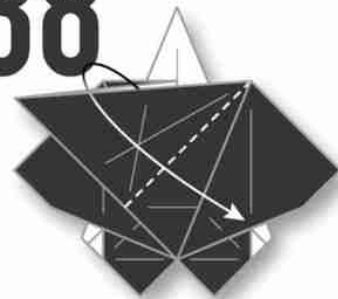

39

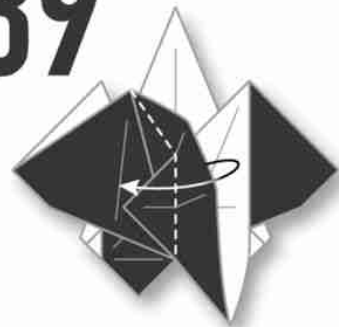

40

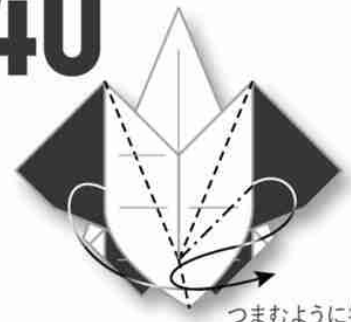

つまむように折る
Rabbit ear fold.

41



42

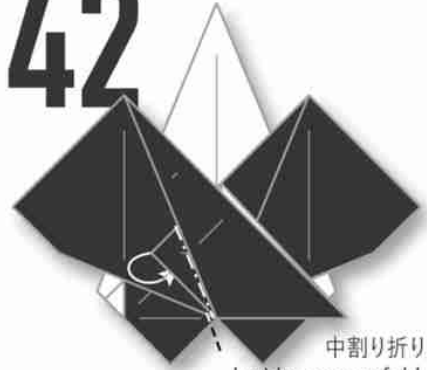

中割り折り
Inside reverse fold.

43

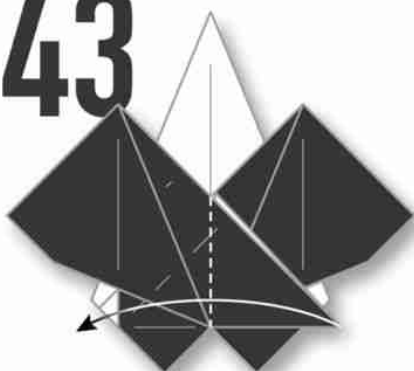

44



45

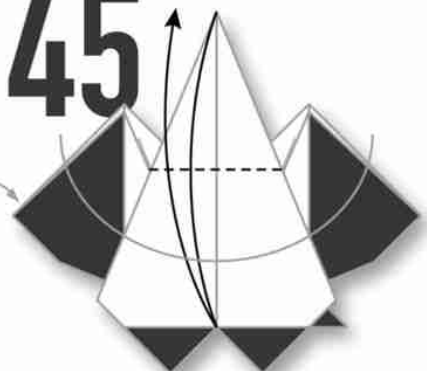

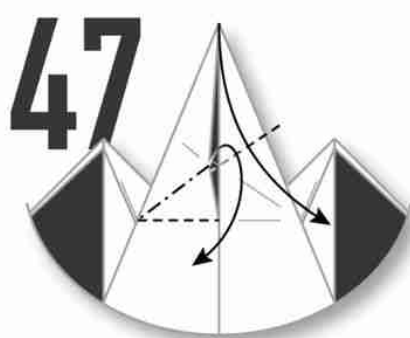
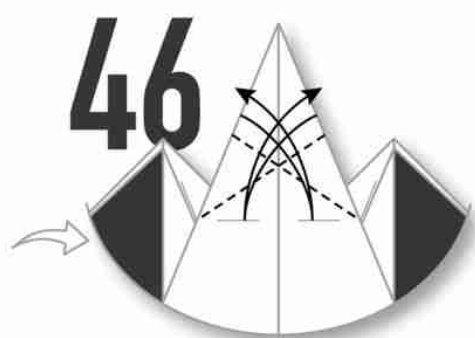

内側を広げて
潰すように折る
Open and squash.

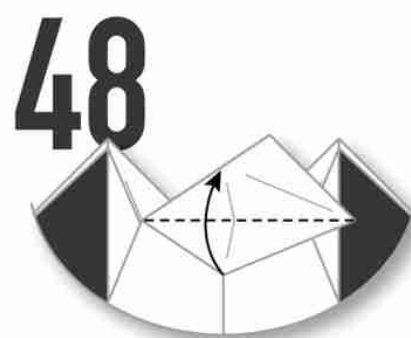

中割り折り
Inside
reverse fold.

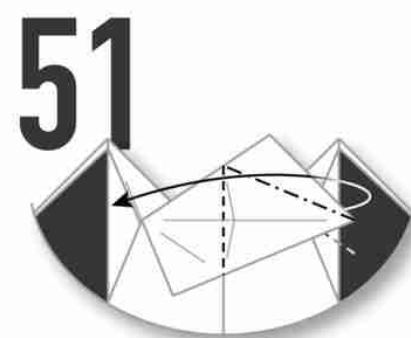
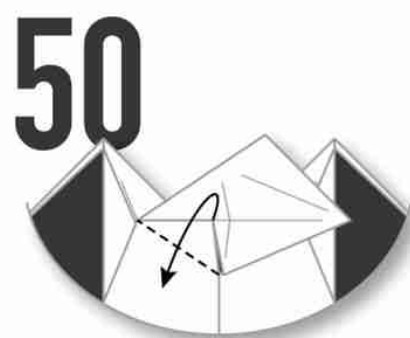

内側を広げて
潰すように折る
Open and squash.

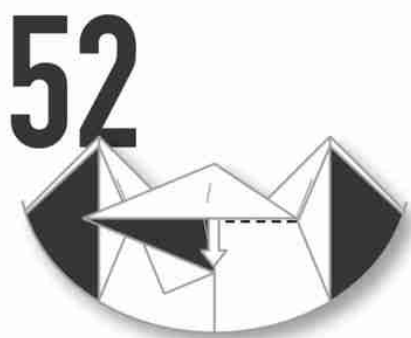

内側の縁を引き出す
Pull out the
inner layer.

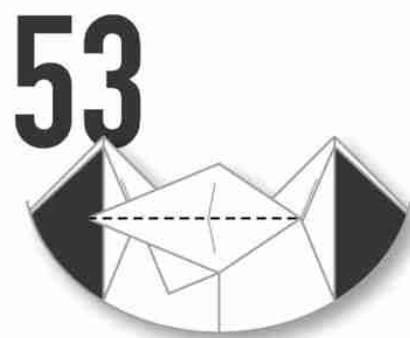

48-50 と
同じように折る
Repeat steps 48-50.

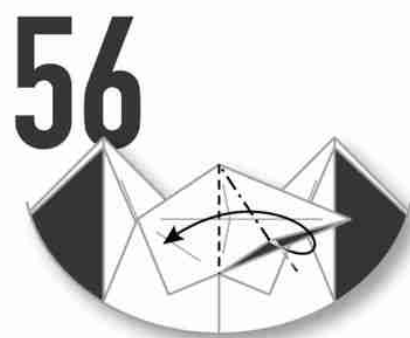
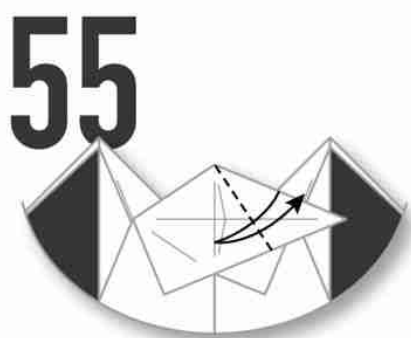
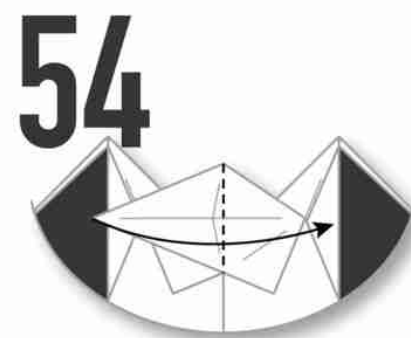

内側を広げて
潰すように折る
Open and squash.



LONG-TAILED TIT

58

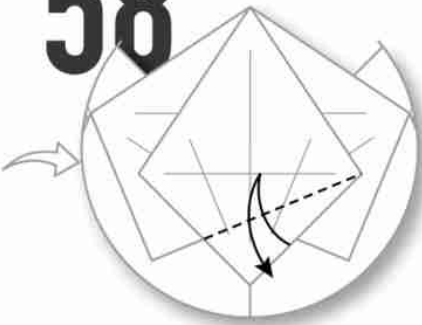

59



60



61



内側を広げて
潰すように折る
Open and squash.

62



縁をめくって
眼を作る
Open the edges and shape eyes.

63



64

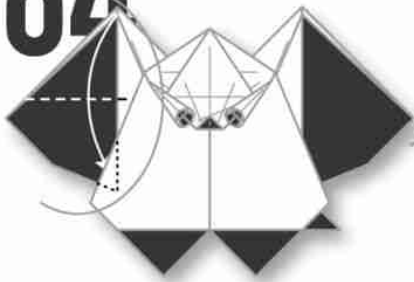

65

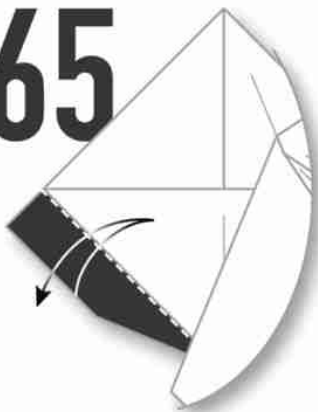

66

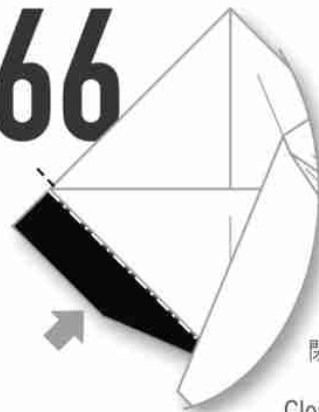

閉じたまま
沈め折り
Closed sink.

67

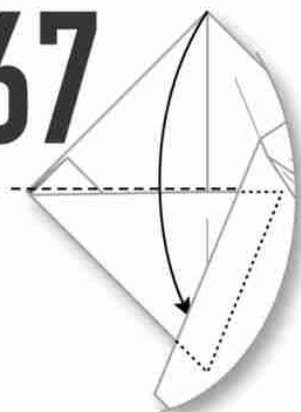

68

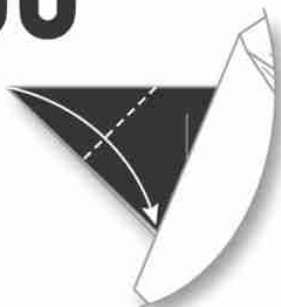

69

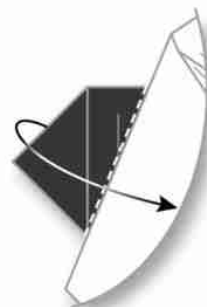

70



反対側も 64-69
と同じように折る
Repeat steps 64-69 on the right.

71

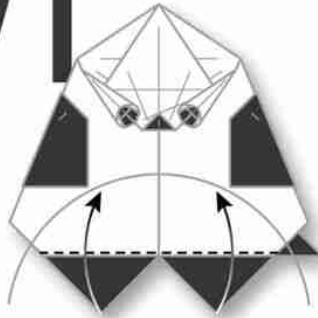

72

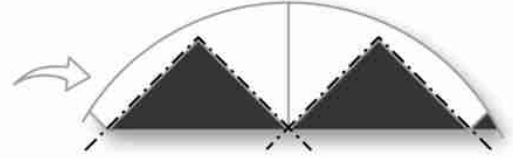

73



カドを
つまむように折る
Rabbit ear fold.

74

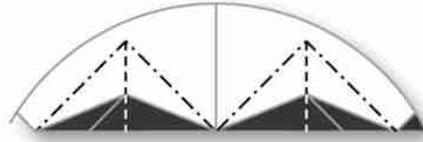

立体化
Make the
model 3D.

75

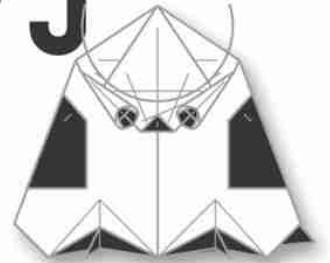

76

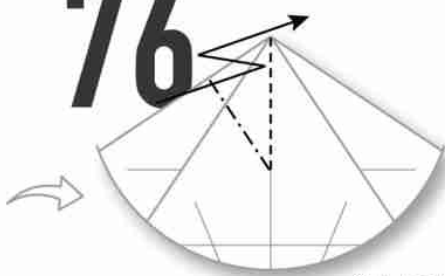

斜めに段折り
Pleat an angle.

77

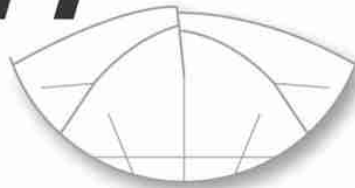

78

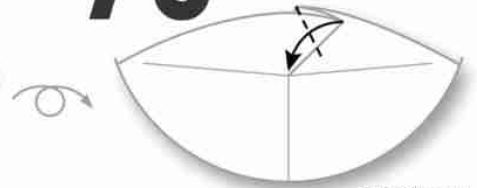

開き留めとして
カドを斜めに折る
Fold the corner
and lock the layers.

79

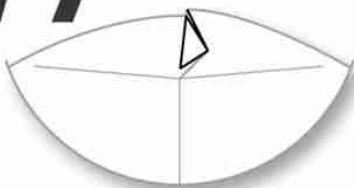

80

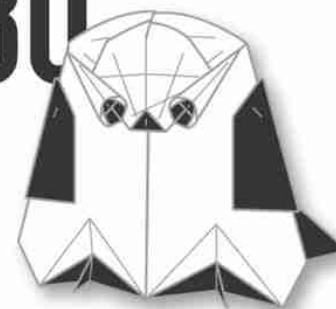

完成
Model completed.

PANDA 2022

ORIGAMI MONO

パンダ 2022
2022



タイトルから溢れ出ている通り、私はパンダを何度も折ってきました。ここで敢えて、何度か引き合いに出されたペンギンをフォローしておきますと、私はペンギンが好きです。小さい頃から「生まれ変わったら何になりたい？」と聞かれてペンギンと答えるくらい好きです。そのペンギンよりも好きで折ってきたパンダの最新作です。

本作の特徴は、立体化を意識した面の出し方です。具体的には頭部が分かりやすいと思いますが、平面のままでは少し横長に見えます。これは、立体化した時に顔面が奥行きとして持っていられる分を考慮しているためです。

As the title overflows, I've created pandas many times. Now if I dare to follow up the penguins that have been referred to several times, I like penguins. Since I was little, I answer penguins when asked "What do you want to be reincarnated as?" And this is the latest work of the panda that I like more than the penguins.

The feature of this work is the surface that is conscious of 3D. Specifically, I think the head is easy to understand, it looks a little horizontally long if it remains flat. This is because the size that the width is used as the depth when it is 3D is taken into consideration.

24cm×24cm
INTERMEDIATE

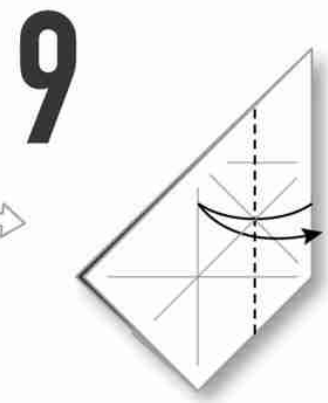
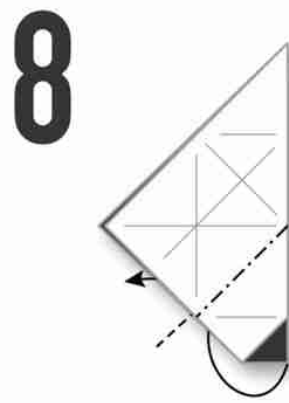
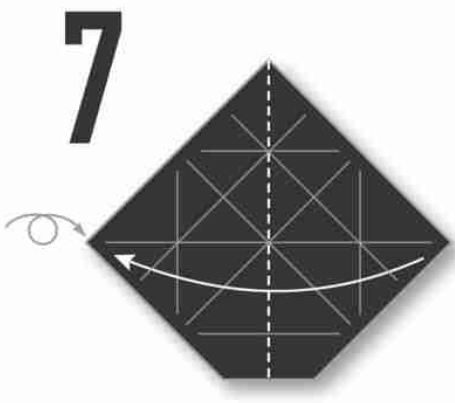
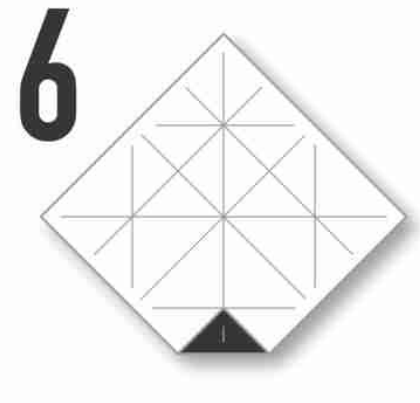
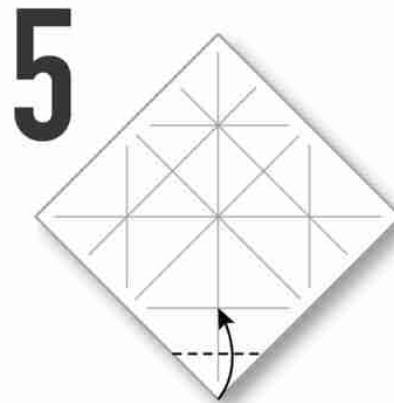
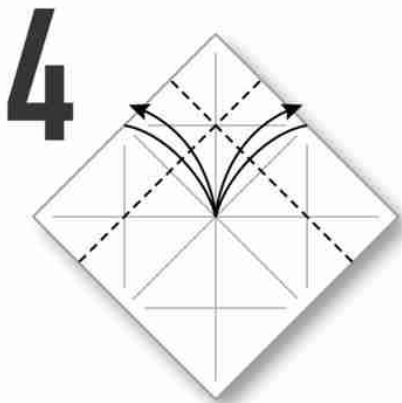
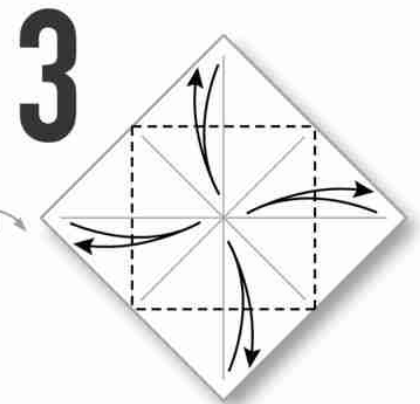
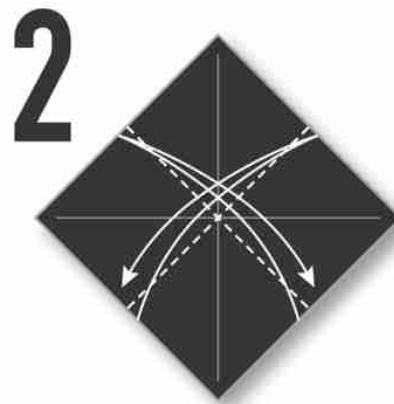
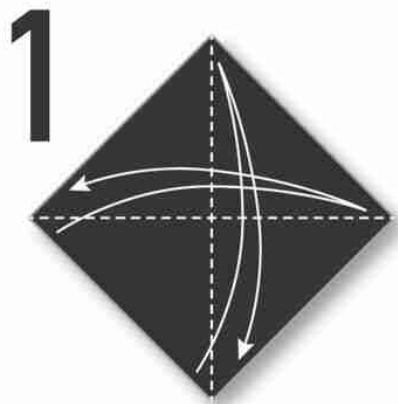
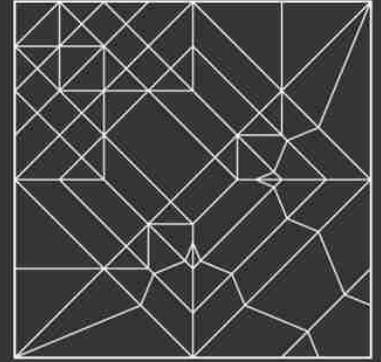

中割り折り
Inside
reverse fold.

PANDA 2022

10

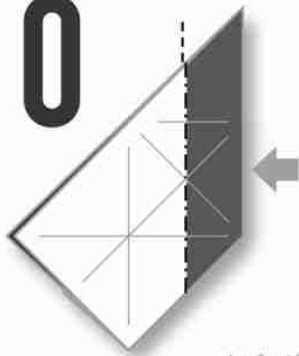

広げて沈め折り
Open sink.

11



ついている
折り筋をつけ直す
Re-crease the
existing crease lines.

12



ヒダを
一度広げ
つけた折り筋
で各ヒダを
中割り折り
するように折る
Make several reverse folds
using the crease lines.

13

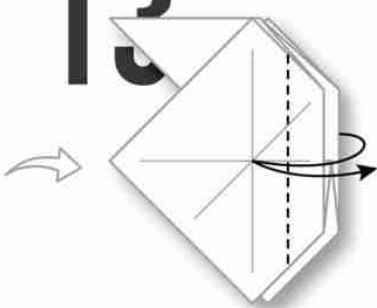

14

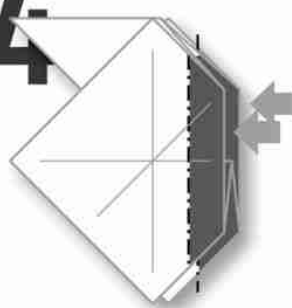

広げて沈め折り
Open sink.

15

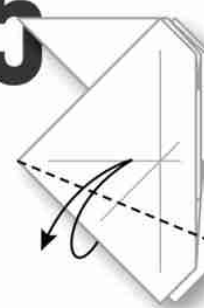

まとめて
折り筋をつける
Make creases on all layers.

16

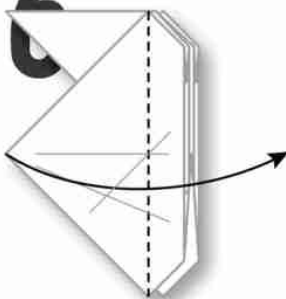

手前のカドをめくる
Fold the top layer.

17

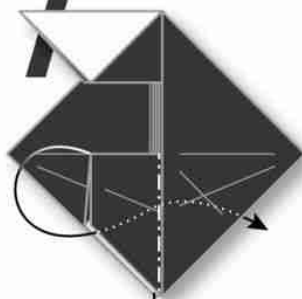

中割り折り
Inside reverse fold.

18

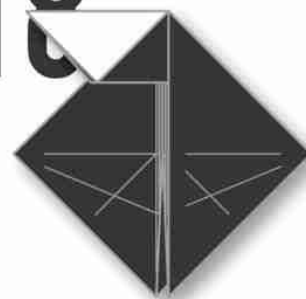

19

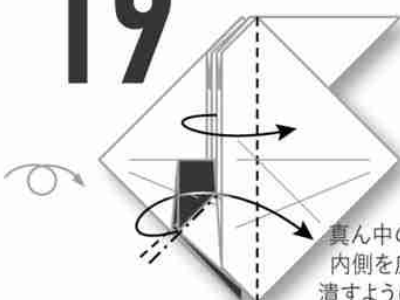

真ん中の層で
内側を広げて
潰すように折る
Open and squash
at the middle layer.

20



中割り折り
Inside reverse fold.

21

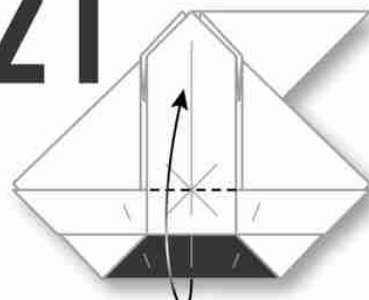

22

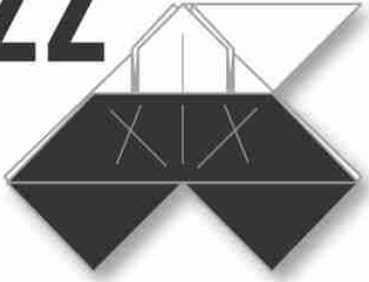

23

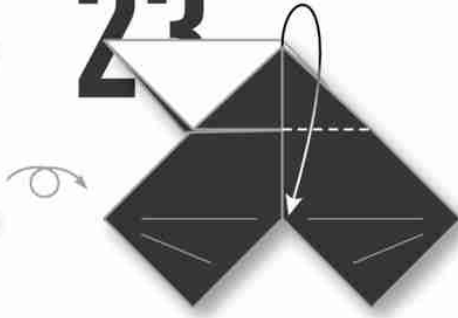

24

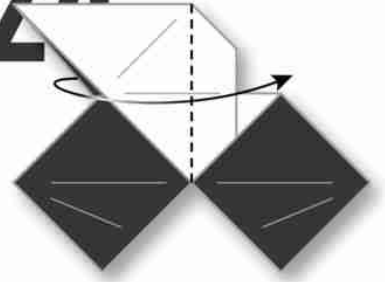

25

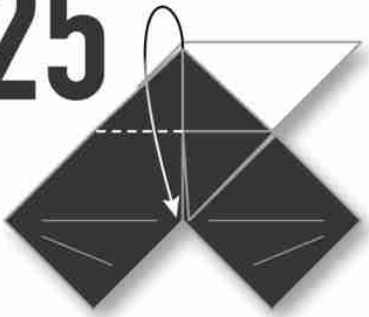

26

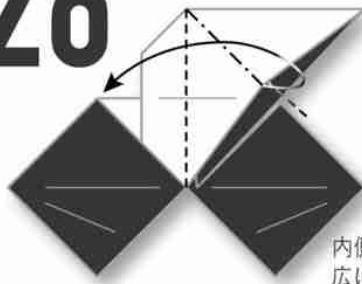

27

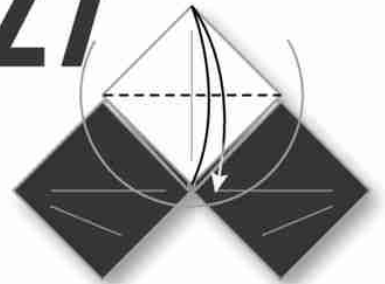

内側を
広げて
潰すように折る
Open and squash.

28

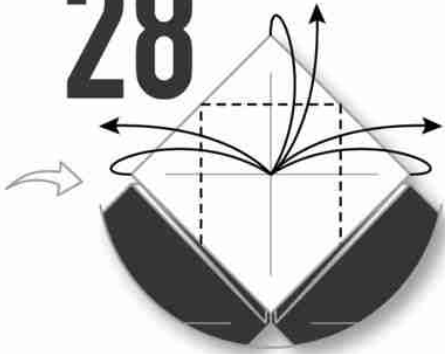

29

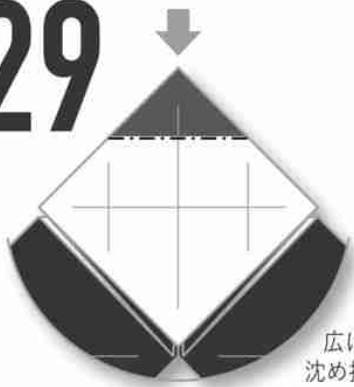

広げて
沈め折り
Open sink.

30

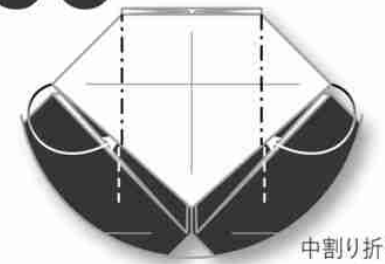

中割り折り
Inside reverse fold.

31

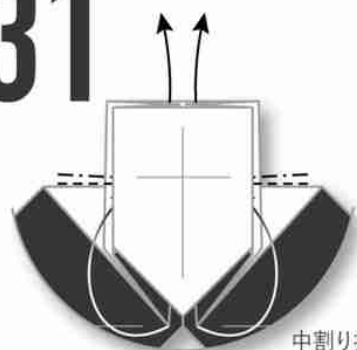

中割り折り
Inside reverse fold.

32



33

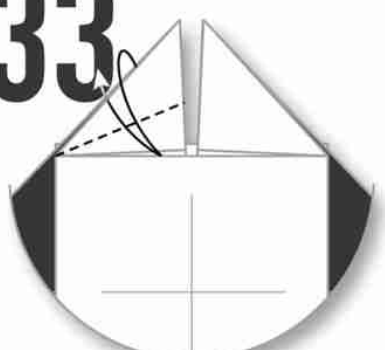

PANDA 2022

34



手前の層で
かぶせ折り
Outside reverse fold
at the top layer.

35

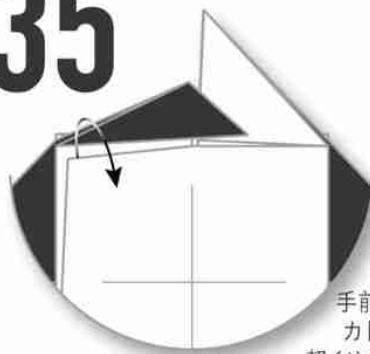

手前の
カドを
軽くめくる
Open the top corner lightly.

36

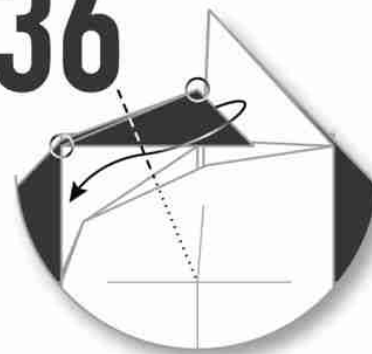

37

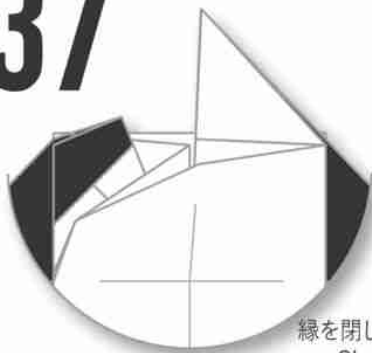

縁を閉じる
Close.

38

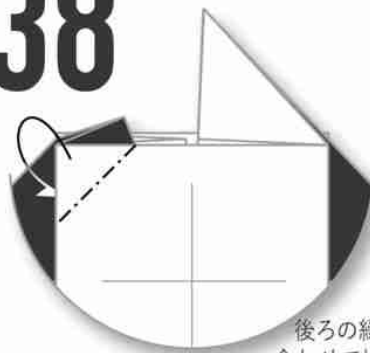

後ろの縁に
合わせて折る
Fold along the back edge.

39

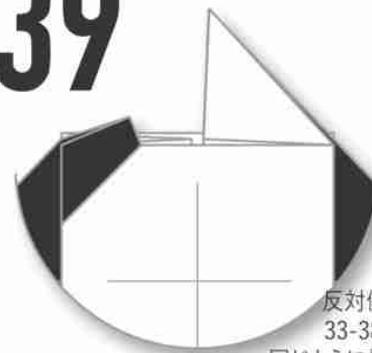

反対側も
33-38と
同じように折る
Repeat steps 33-38 on the right.

40

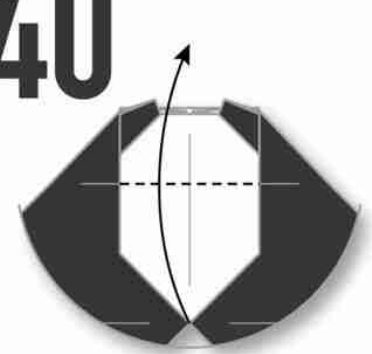

41

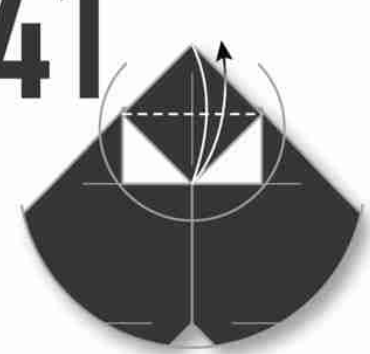

42



43



44



45

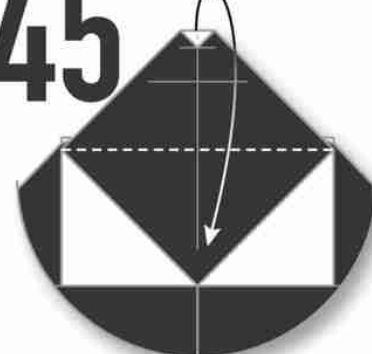

46

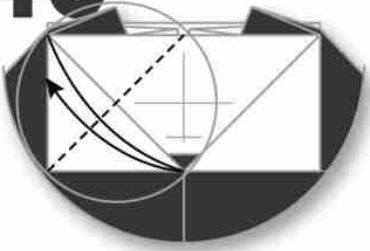

47

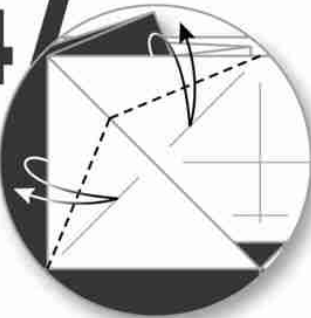

48

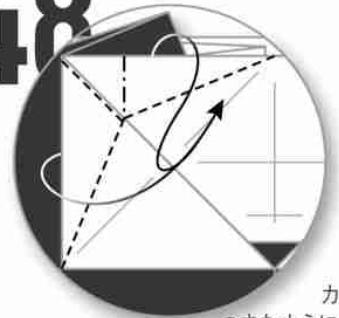

カドを
つまむように折る
Rabbit ear fold.

49



内側の縁を
引き出す
Pull out the inner layer.

50

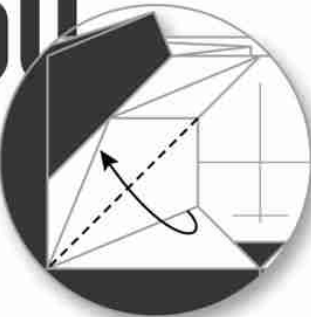

51

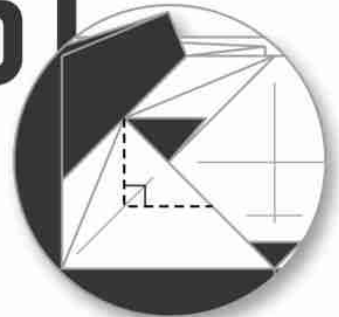

52

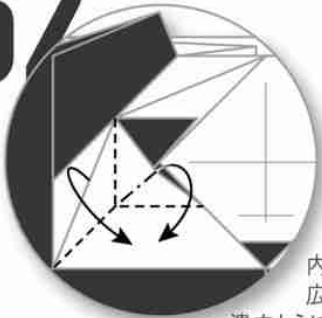

内側を
広げて
潰すように折る
Open and squash.

53

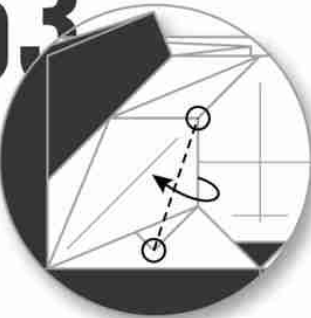

54

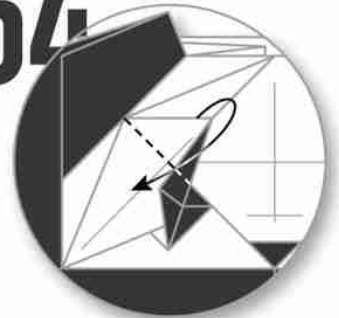

55

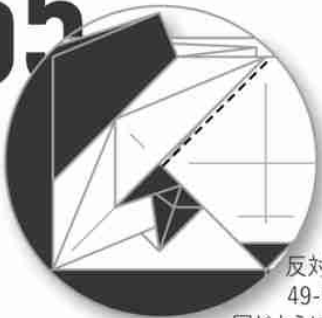

反対側も
49-53と
同じように折る
Repeat steps 49-53.

56

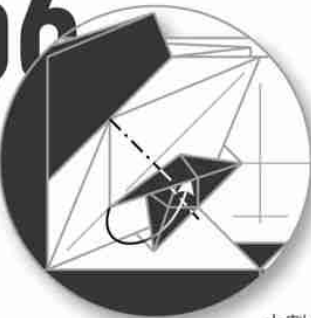

中割り折り
Inside reverse fold.

57



PANDA 2022

58

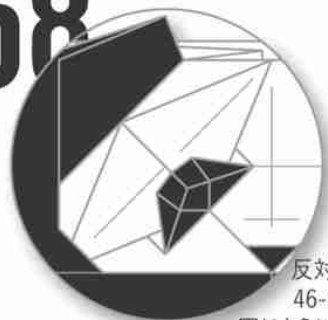

反対側も
46-57と
同じように折る

Repeat steps 46-57 on the right.

59

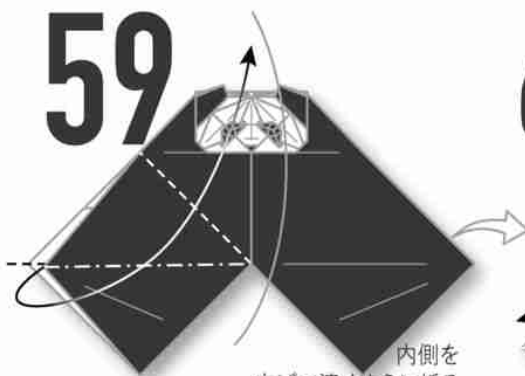

内側を
広げて潰すように折る
Open and squash.

60

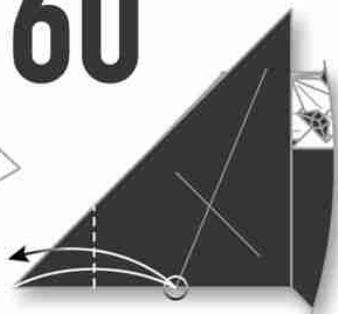

61

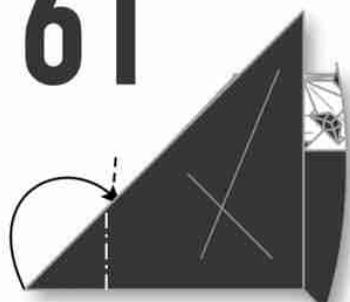

中割り折り
Inside reverse fold.

62

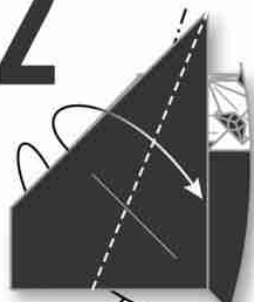

かぶせ折り
Outside reverse fold.

63

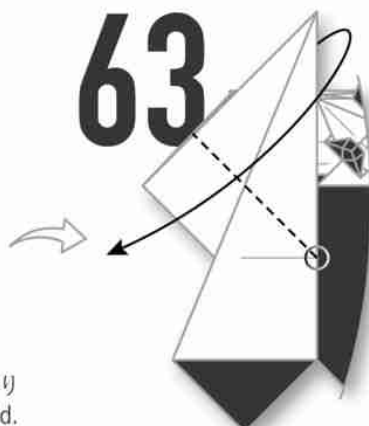

64



65



引き寄せる
ように折る
Swivel inside.

66



手前の層に
カドを差し込む
Insert the corner
into the top pocket.

67



68



中割り折り
Inside reverse fold.

69



反対側も
59-68と
同じように折る
Repeat steps
59-68 on the right.

70

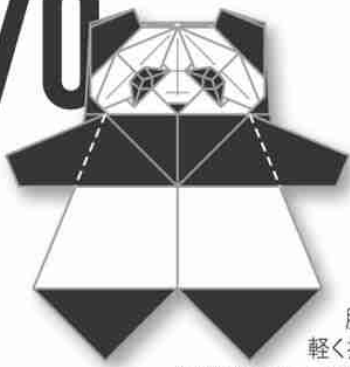

腕を
軽く折る
Fold the arms lightly.

71

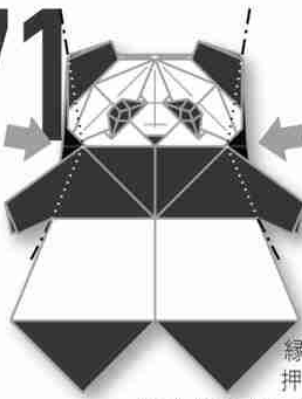

縁を軽く
押し込む
Push the edges lightly.

72

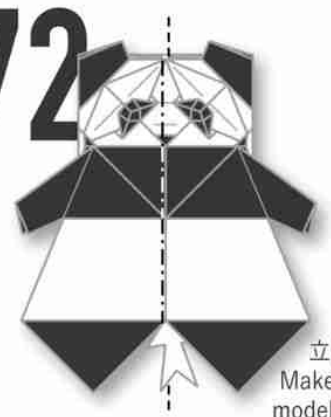

立体化
Make the
model 3D.

73

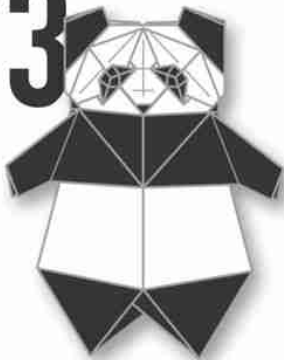

完成
Model completed.

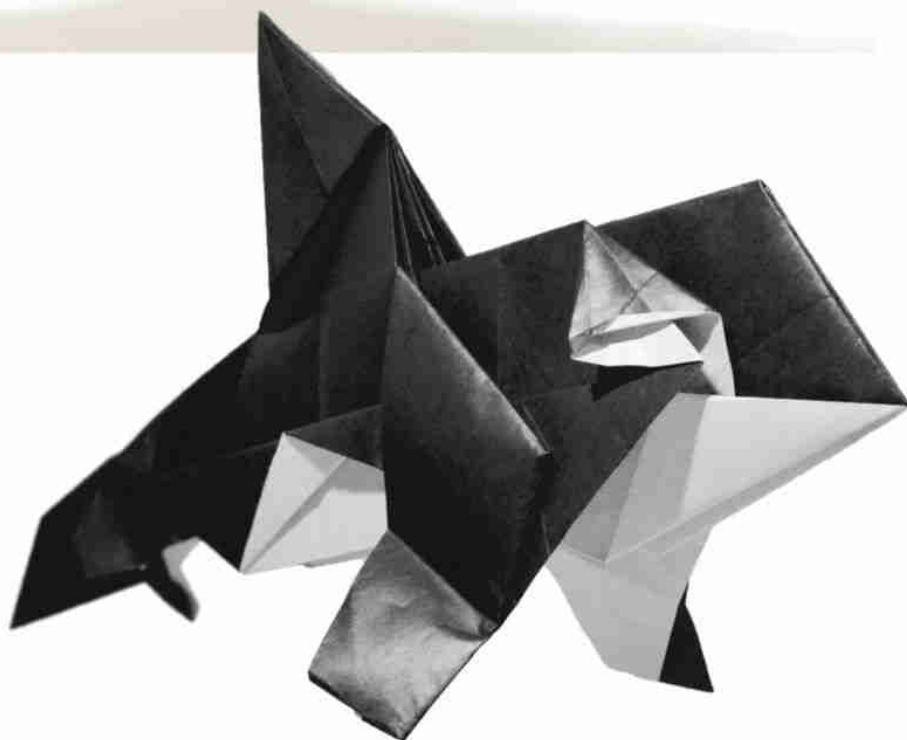
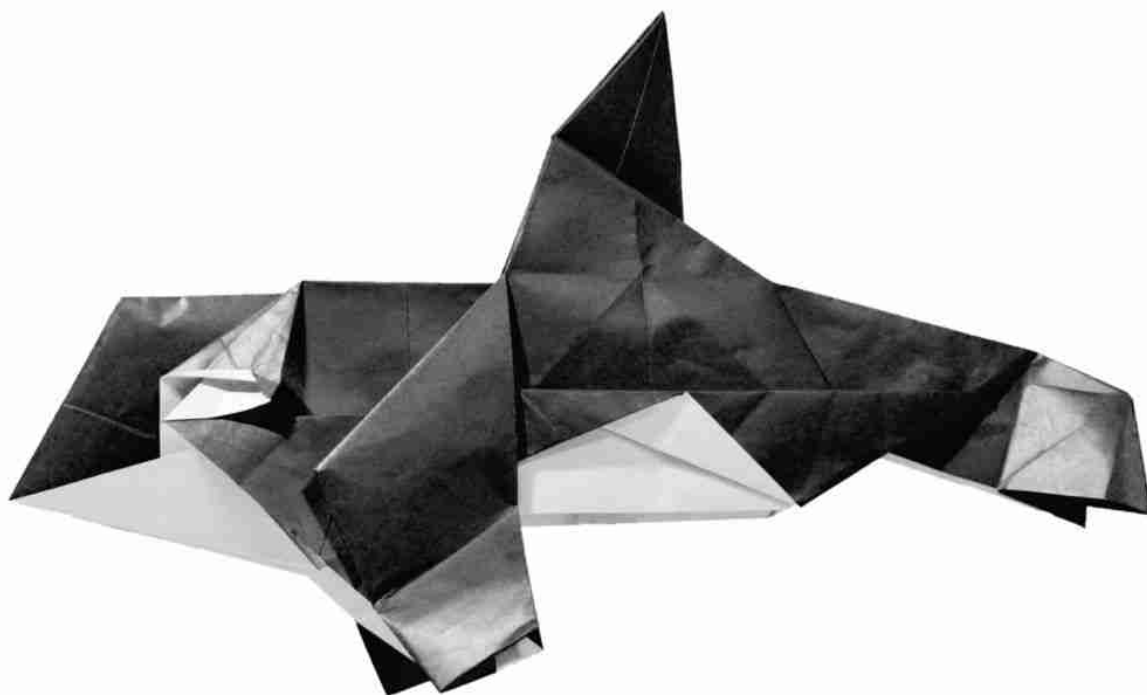

折り紙の創作は基本的に試行錯誤の繰り返しですが、この作品は幸運にも初回の試作でほぼ仕上がりました。

アヤメの基本形の中央カドを背ビレに、紙の4つのカドをそれぞれ頭、両胸ビレ、尾ビレに使いつつ、紙の縁で模様を折るといふ、直感的な構造です。この「紙の縁で模様を折る」というのがインサイドアウトの肝です。紙の中央からは色変えはできません。そこで設計弱者の私からすると、本書シマウマやホワイトタイガーのように、紙の中央を持って余した上で折りにくく、仕上げにも苦労するというものが誕生してしまいます。シャチには背ビレがあってよかったなと思います。

Designing origami is basically a process of trial and error, but fortunately this work was almost completed with the first prototype.

Made with a frog base, using the center corner as the dorsal fin, the four paper corners as the head, both chest fins and tail fin, and the edges as the color change. This "using the edge as the color change" is the core of the inside out. We cannot change the color at the center of the paper. So, as a weak designer, I don't know what to do with the center of the paper, like the "Zebra" and "White Tiger" in this book, and it can be difficult to fold and shape. It was good for me that the orca had dorsal fin.

20cm×20cm
INTERMEDIATE

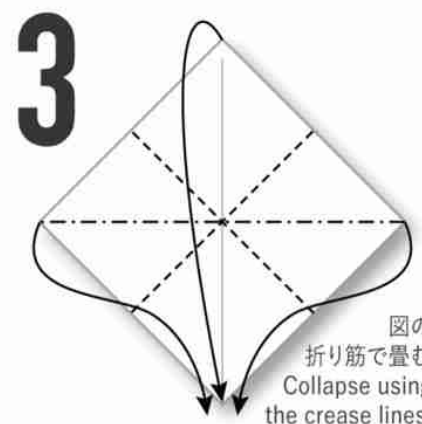
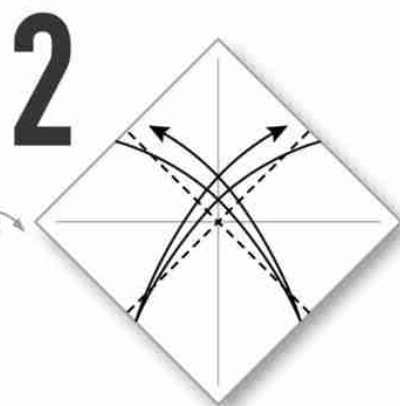
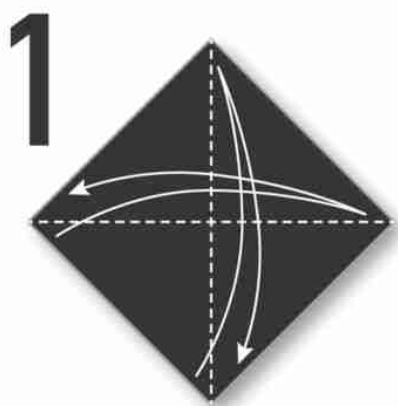
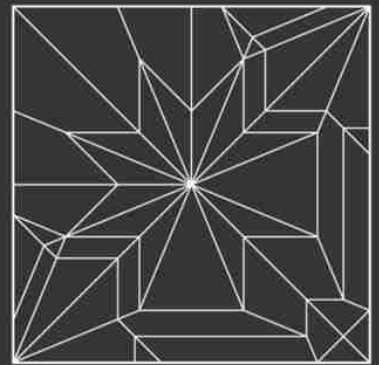

図の折り筋で畳む
Collapse using the crease lines.

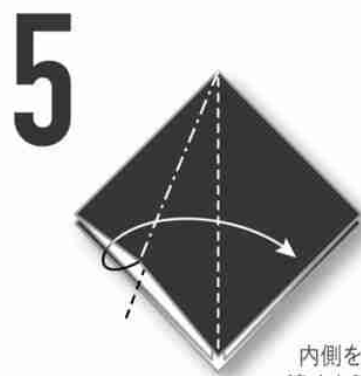
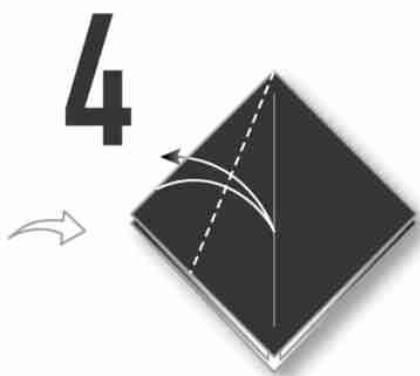

内側を広げて潰すように折る
Open and squash.

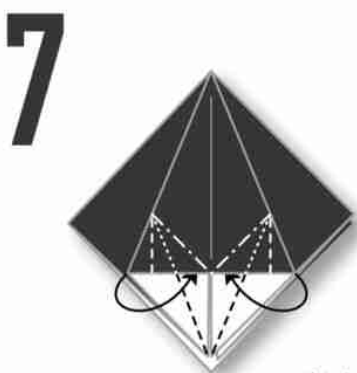
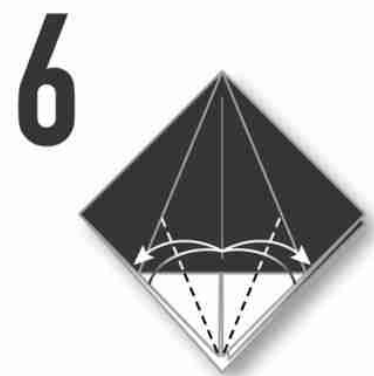

引き寄せ折り
Swivel inside.

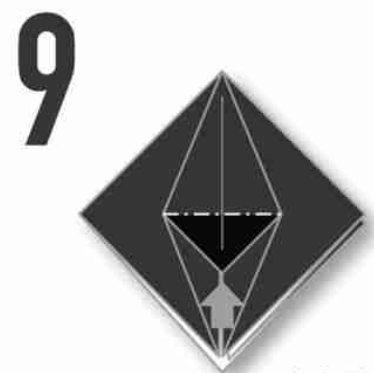
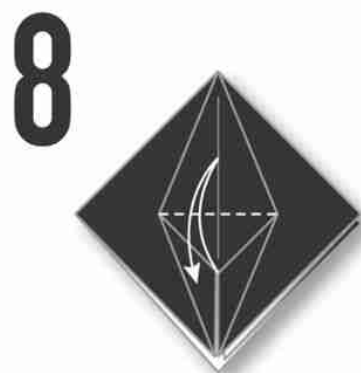

広げて沈め折り
Open sink.

ORCA

10



11

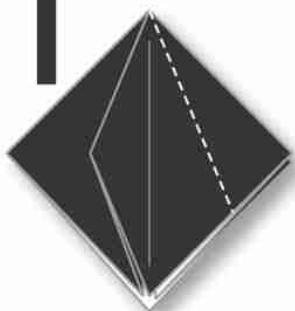

4-9 と
同じように折る
Repeat steps 4-9.

12



13

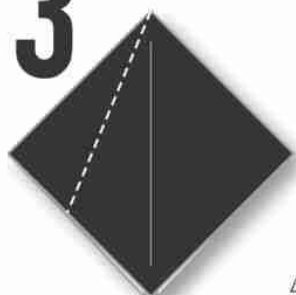

4-11 と
同じように折る
Repeat steps 4-11.

14

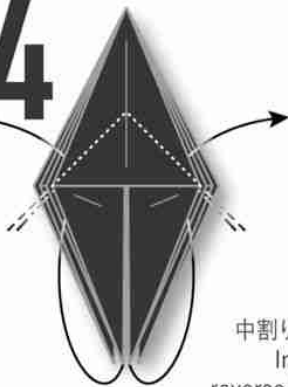

中割り折り
Inside
reverse fold.

15



16

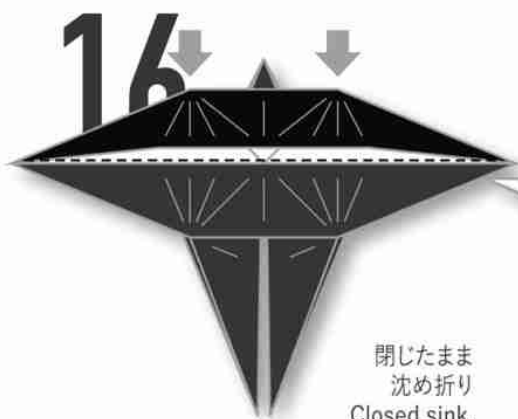

閉じたまま
沈め折り
Closed sink.

17

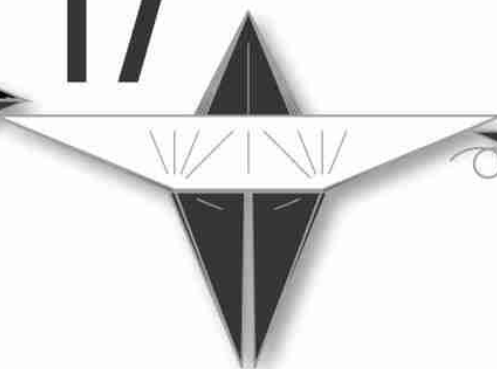

18

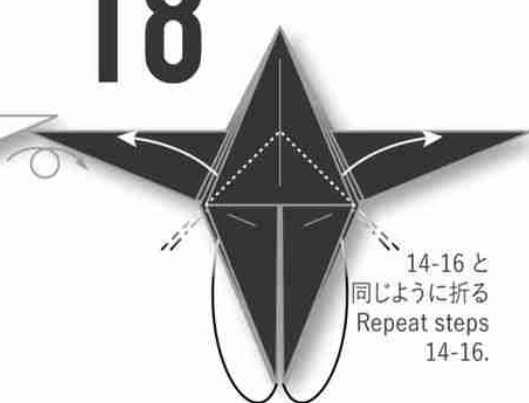

14-16 と
同じように折る
Repeat steps
14-16.

19

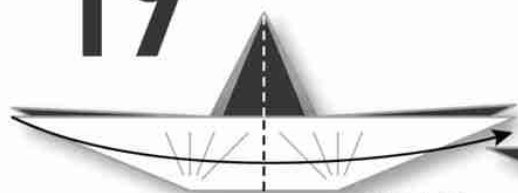

手前のカドを
右に折る
Fold the top corner
to the right.

20

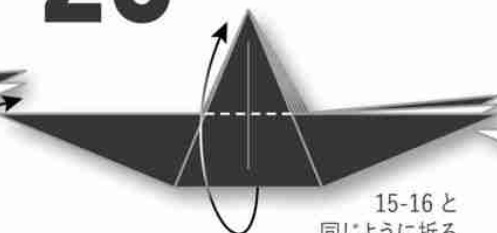

15-16 と
同じように折る
Repeat steps
15-16.

21



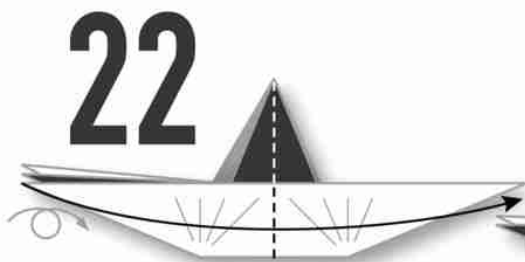

手前のカドを
右に折る
Fold the top corner
to the right.



15-16と
同じように折る
Repeat steps
15-16.

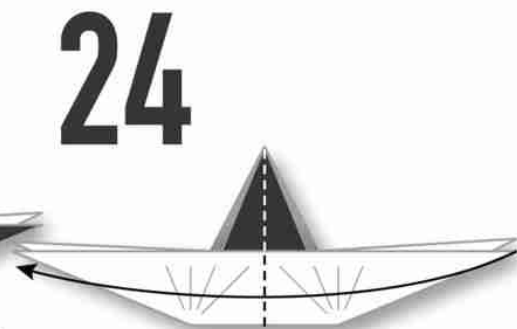

手前のカドを左に折る
Fold the top corner
to the left.



手前のカドに
折り筋をつける
Make a crease
on the top layer.

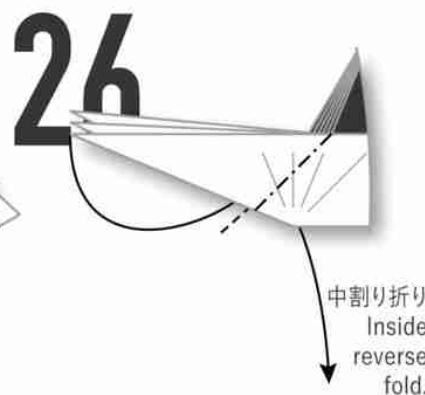

中割り折り
Inside
reverse
fold.



手前の
縁を折る
Fold the
top layer.



縁を
めくって裏返す
Reverse the paper
wrapping the corner.

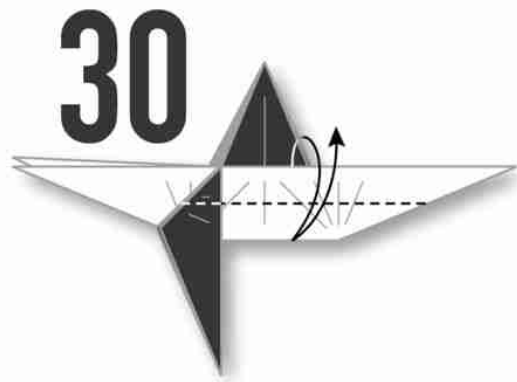

裏側も
25-30と
同じように折る
Repeat steps
25-30 behind.

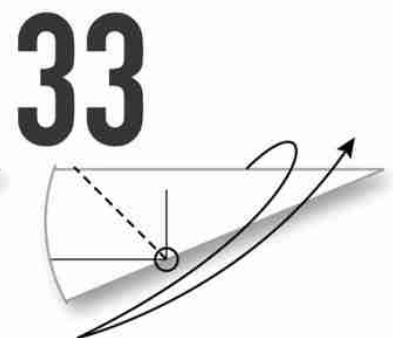
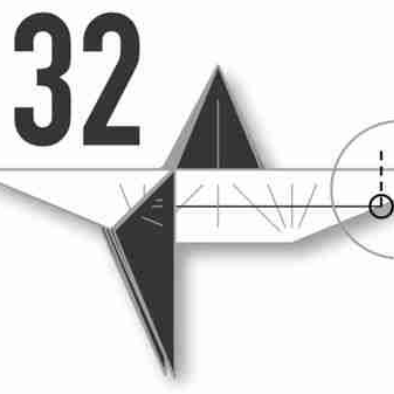

ORCA

34

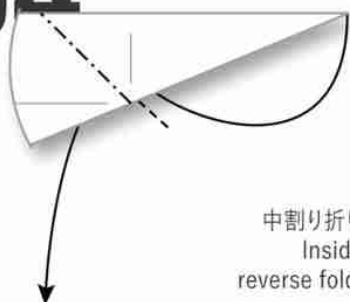

中割り折り
Inside
reverse fold.

35

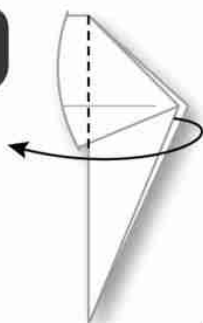

手前の
縁を折る
Fold the
top layer.

36



縁を
めくって裏返す
Reverse the paper
wrapping the corner.

37

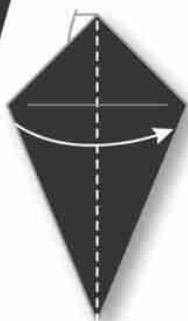

38

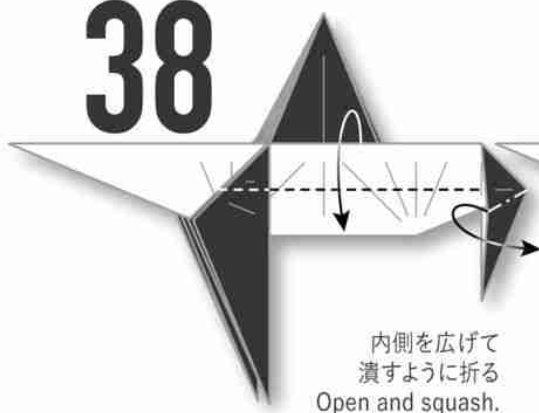

内側を広げて
潰すように折る
Open and squash.

39

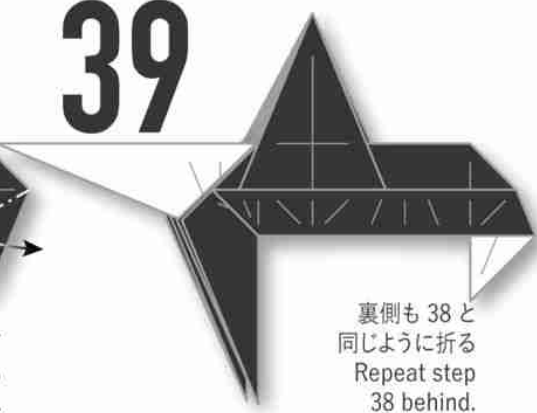

裏側も 38 と
同じように折る
Repeat step
38 behind.

40



手前の
縁を折る
Fold the top layer.

41

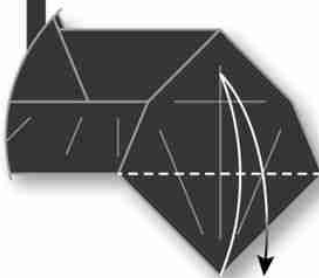

42

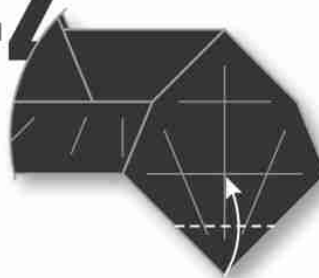

43

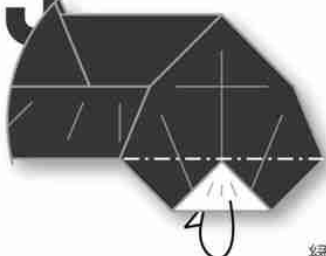

縁を
内側に折り込む
Fold the edge to the pocket.

44

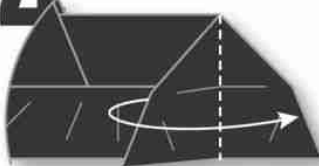

45



46

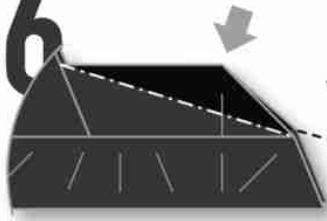

広げて
沈め折り
Open sink.

47

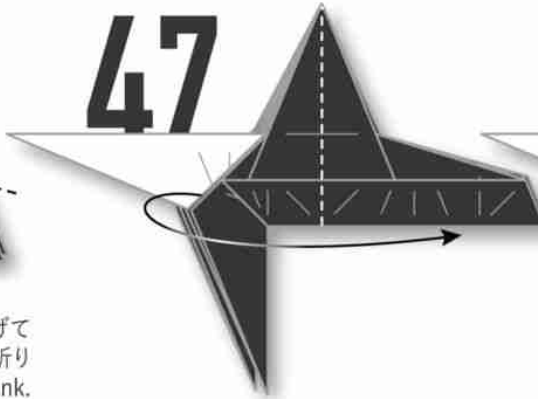

48

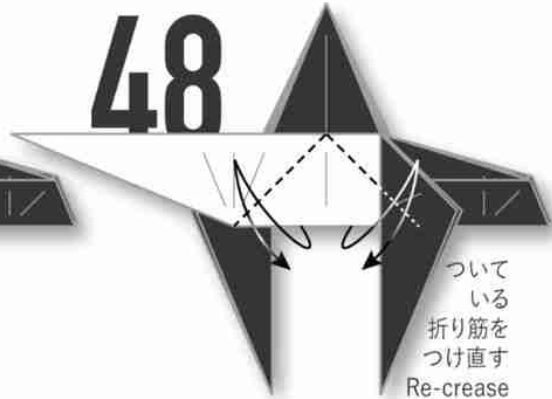

ついて
いる
折り筋を
つけ直す
Re-crease
the existing crease lines.

49

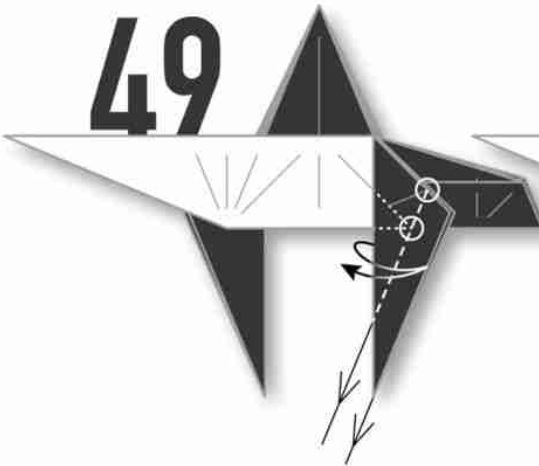

50

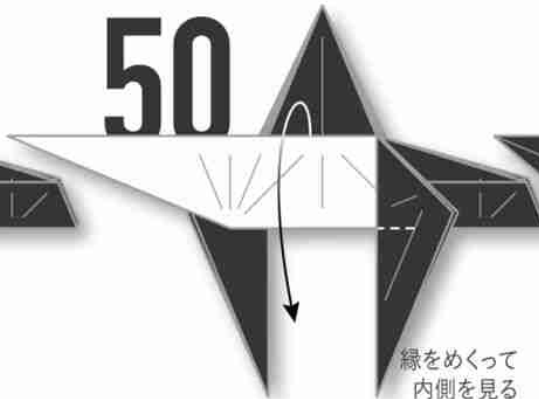

縁をめぐって
内側を見る
Open the edge lightly.

51



52



図のような
折り筋で畳む
Flatten the model as shown.

53



途中の図
In progress...

54



55

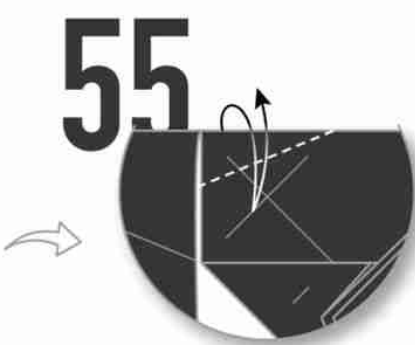

56

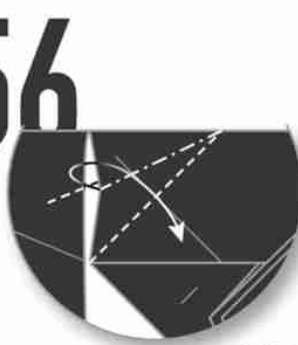

内側を広げて
潰すように折る
Open and squash.

57



58



縁を引き寄せ
るように折る
Swivel fold.

59



裏側も
47-58 と
同じように折る
Repeat steps
47-58 behind.

60

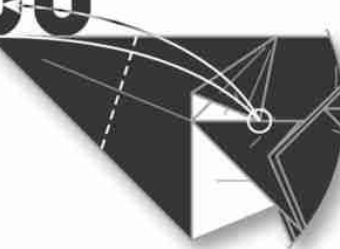

61

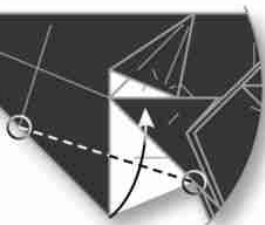

62



63

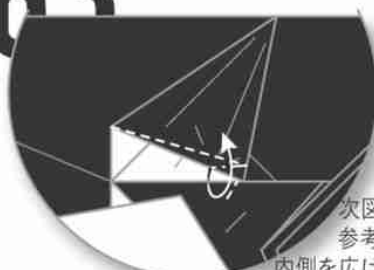

次図を
参考に
内側を広げて
潰すように折る
Open and squash.
Refer to the next step.

64



裏側も
61-63 と
同じように折る
Repeat steps 61-63 behind.

65

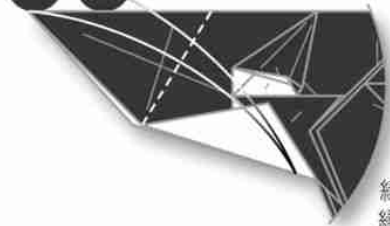

縁と
縁を
合わせて折り筋をつける
Fold the edge to edge and unfold.

66

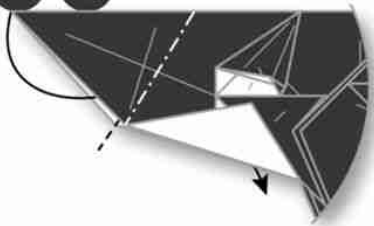

中割り折り
Inside reverse fold.

67



開き留めとして
内側のカドを斜めに折る
Fold the inner corner
and lock the layers.

68

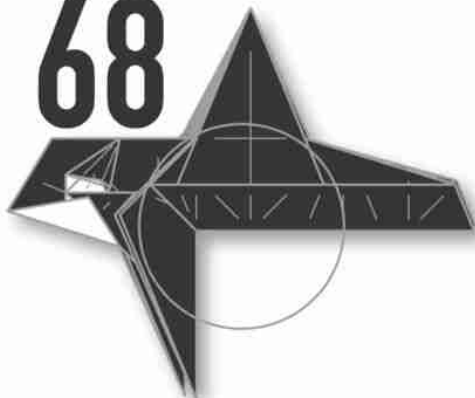

69



ついている折り筋と
縁を合わせて
折り筋をつける
Fold the existing
crease line to the
edge and unfold.

70



69でつけた折り筋と
縁を合わせて
折り筋をつける
Fold the crease line
made in step 69
to edge and unfold.

71

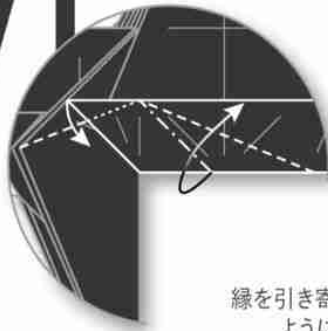

縁を引き寄せる
ように折る
Swivel outside.

72



73



74



手前の
縁を折る
Fold the
top layer.

75



閉じ
たまま
沈め折り
Closed sink.

76

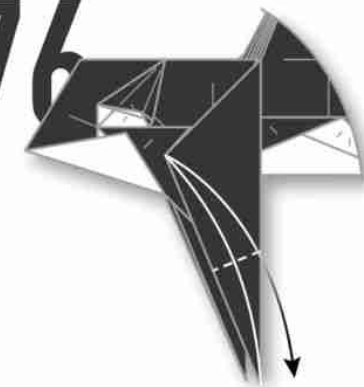

77



中割り折り
Inside reverse fold.

78



79



裏側も
69-78と同じ
ように折る
Repeat steps 69-78 behind.

80

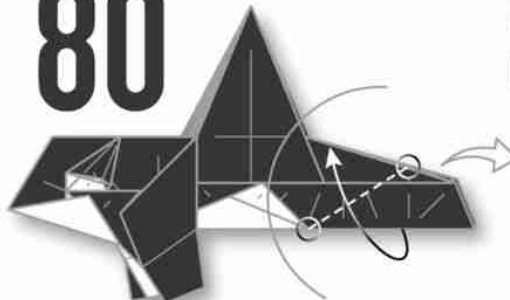

81

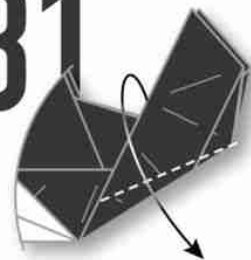

82

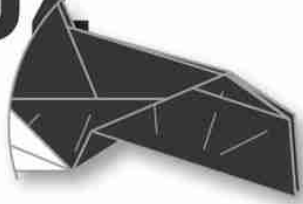

80 の状態
に戻す
Unfold to step 80.

83

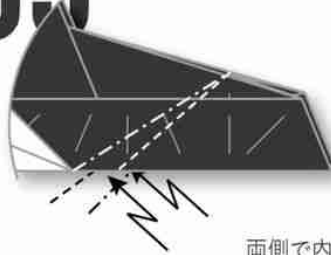

両側で内側に
向かって段折り
Crimp inside.

84

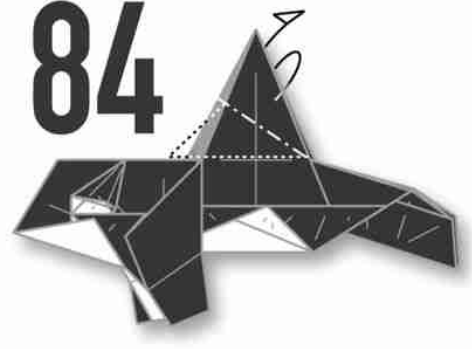

85

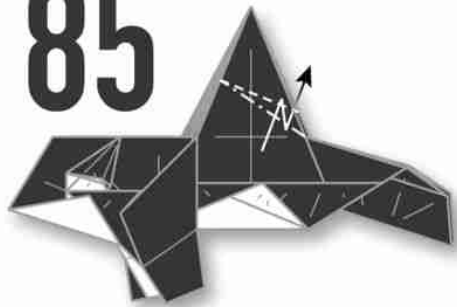

86

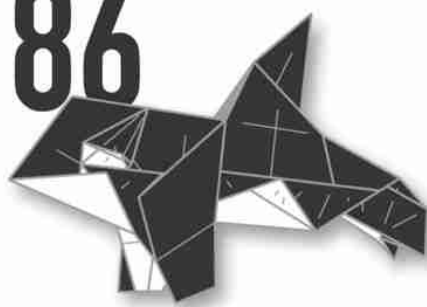

完成
Model completed.



COW

35cm×35cm

COMPLEX



座布団小鳥の基本形を使った牛を初めて創作したのは2014年でした。そこから2015年、2020年と改修を続け、2021年に過去に私が創作したシンプルな「うし」(山口真、『新世代 至高のおりがみ』。西東社、2018)の頭部の折り方とハイブリッドし、このような形になりました。同年の九州コンベンションの講習作品でもあります。

後脚は紙が薄く貧弱です。自立しない場合は厚紙を挟むなど補強して下さい。

It was in 2014 that I first created a cow using the blintz little bird base. From there, it continued to improve in 2015 and 2020, and in 2021, I hybridized the head of my simple Cow (Makoto Yamaguchi, "New Generation of Origami". Seitosha, 2018), and became like this. It is also a work of the Kyushu Convention class of the same year.

The hind legs are thin and poor. If not stand on its own, reinforce by inserting thick paper.

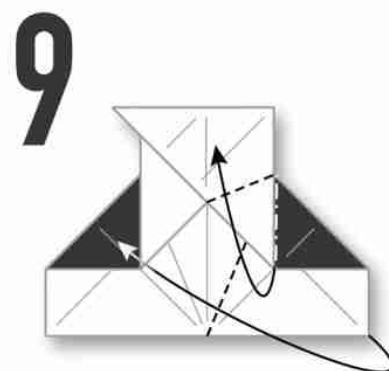
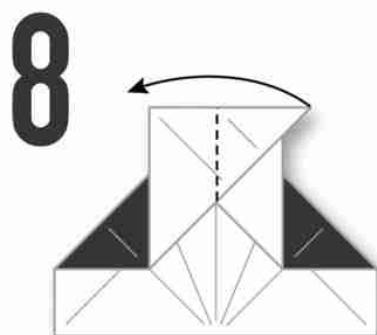
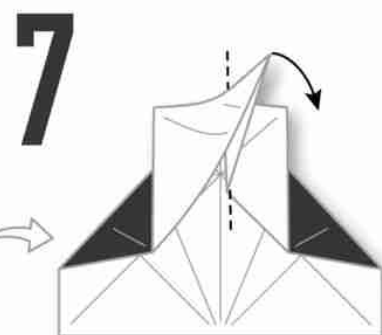
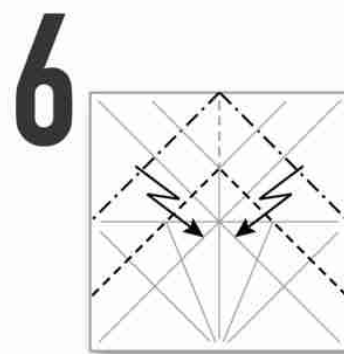
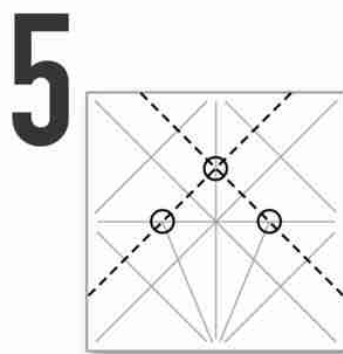
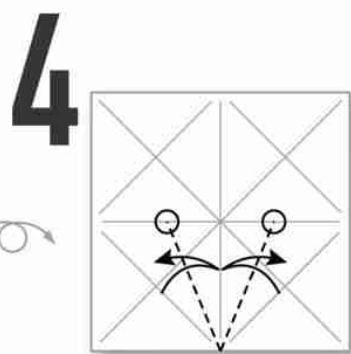
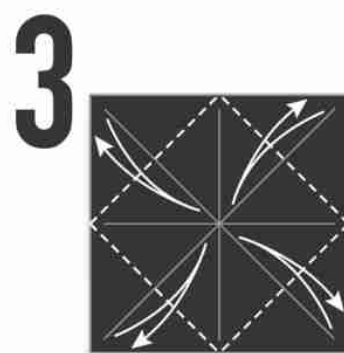
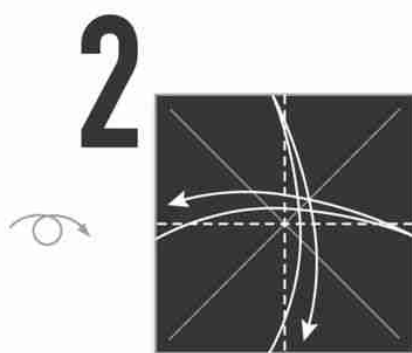
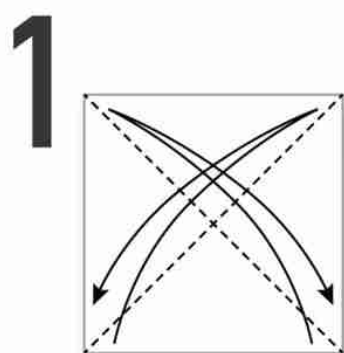
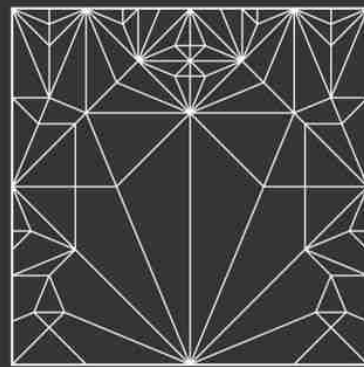

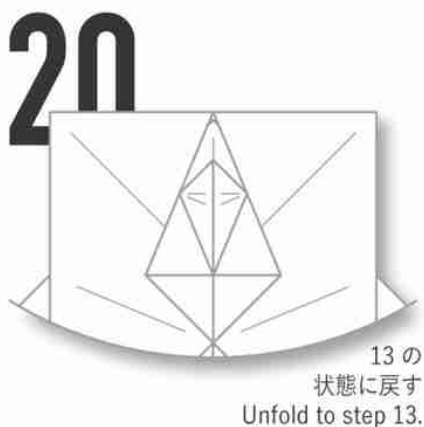
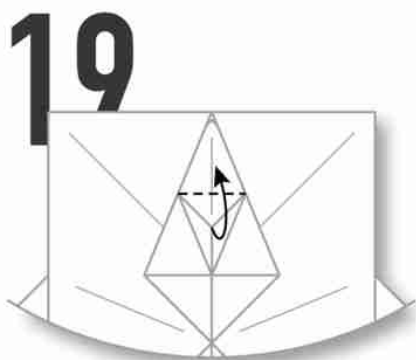
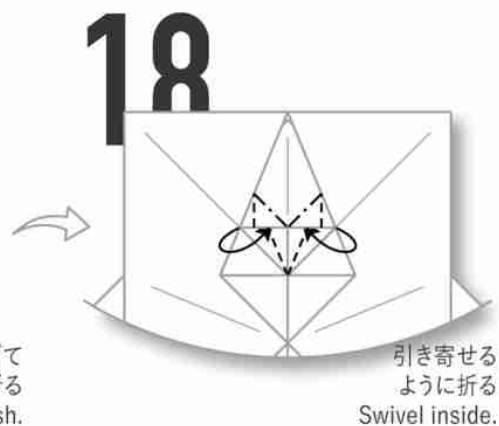
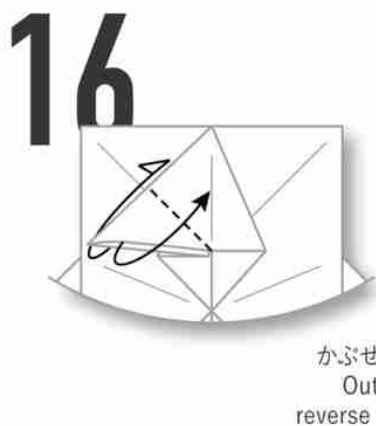
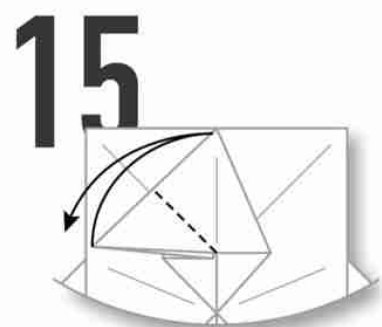
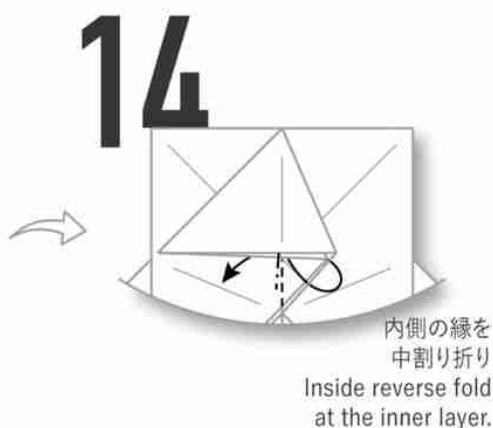
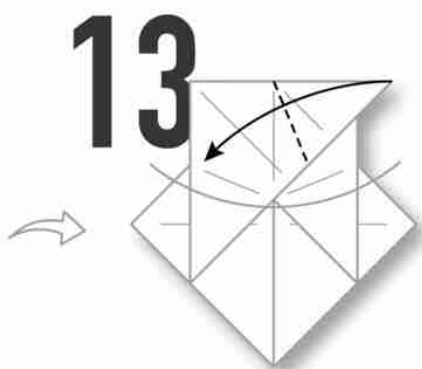
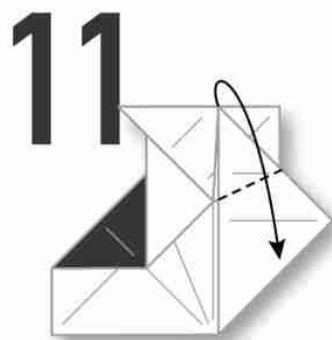
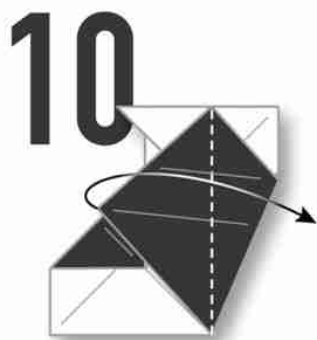

22

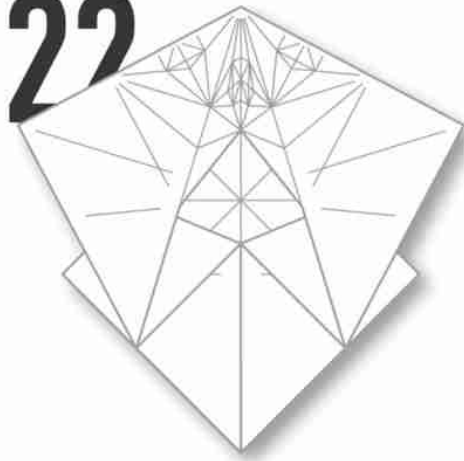

23



図の位置で
沈めながら
平面に畳む

Sink the edges as shown and flatten.

24

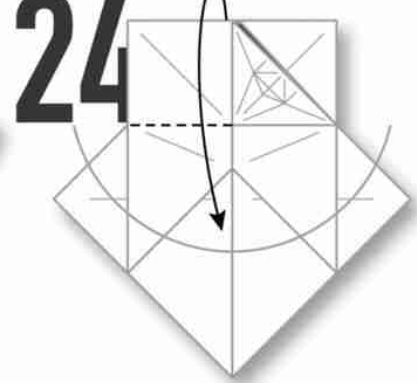

25

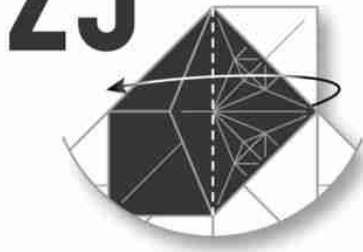

26

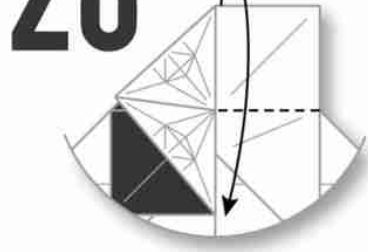

27



内側を広げて
潰すように折る
Open and squash.

28



縁を
つまむように折る
Pinch the edge.

29

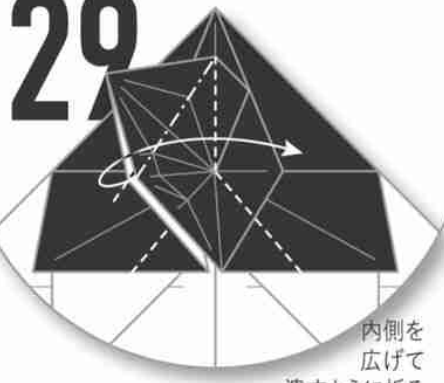

内側を
広げて
潰すように折る
Open and squash.

30



内側を
広げて
潰すように折る
Open and squash.

31



下の
部分
を引き寄せ
ながら斜めに段折り
Swivel and pleat angles.

32

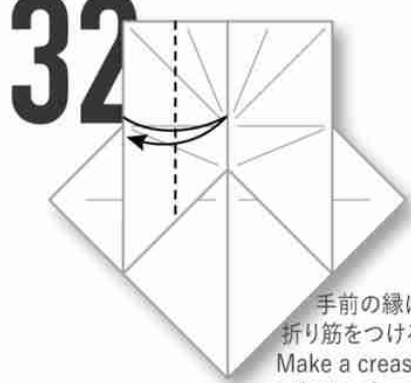

手前の縁に
折り筋をつける
Make a crease
at the top layer.

33

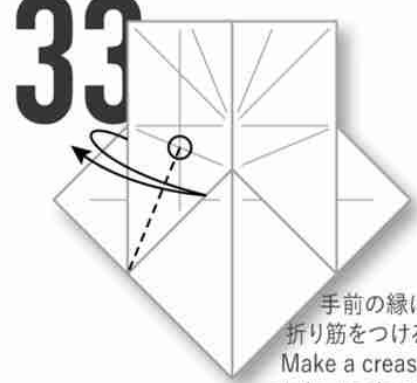

手前の縁に
折り筋をつける
Make a crease
at the top layer.

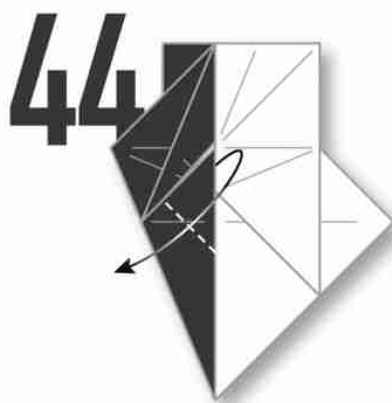
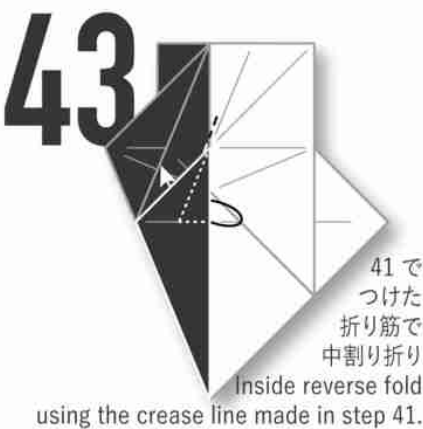
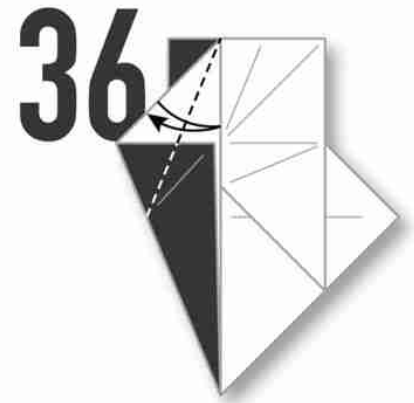
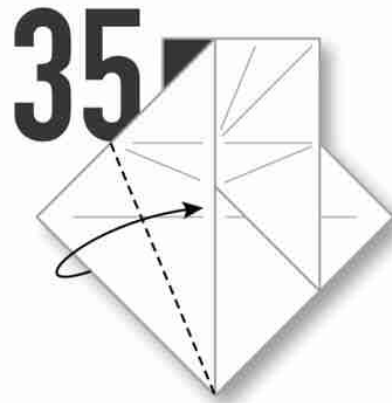
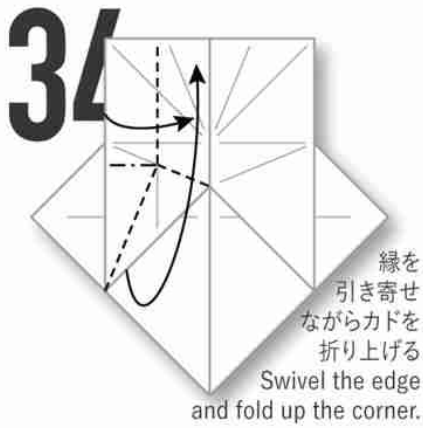



46 の状態
に戻す
Unfold to step 46.

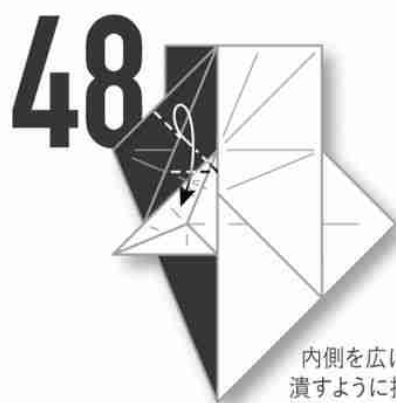

内側を広げて
潰すように折る
Open and squash.

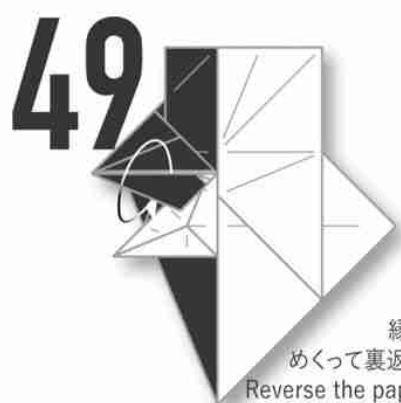

縁を
めくって裏返す
Reverse the paper
wrapping the corner.

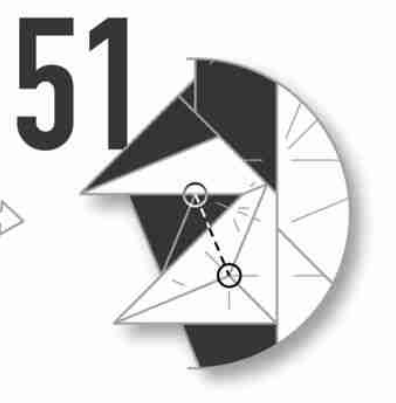

つけた
折り筋で
内側を広げて
潰すように折る
Open and squash
using existing crease lines.

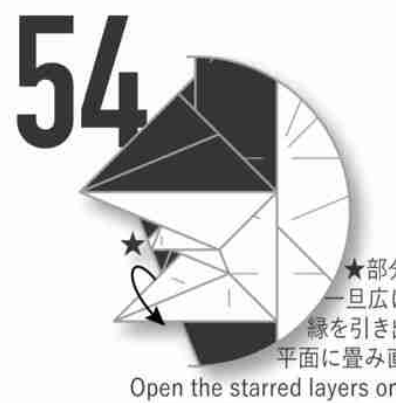

★部分を
一旦広げる
縁を引き出し
平面に畳み直す
Open the starred layers once.
Pull out the edge and flatten.

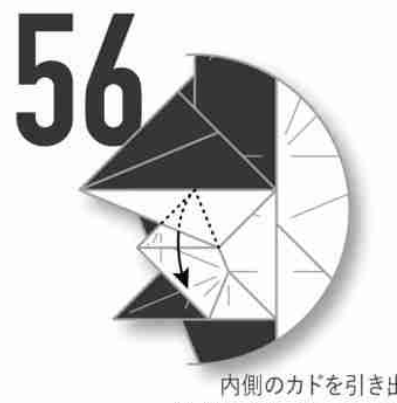

内側のカドを引き出す
Pull out the inner corner.



58

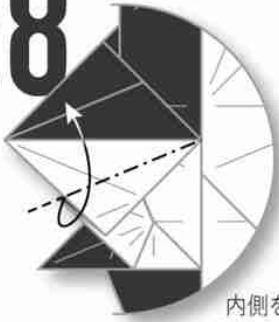

内側を広げて
潰すように折る
Open and squash.

59

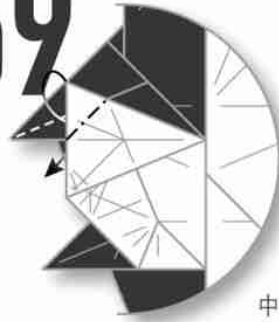

中割り折り
Inside
reverse fold.

60

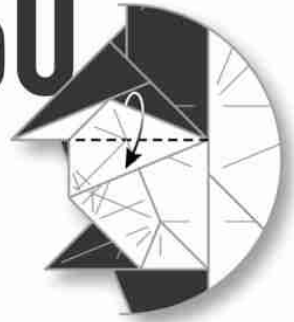

61

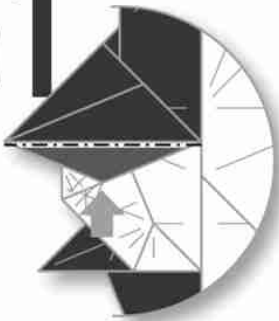

広げて
沈め折り
Open sink.

62



反対側も
32-61 と
同じように折る
Repeat steps
32-61 on the right.

63

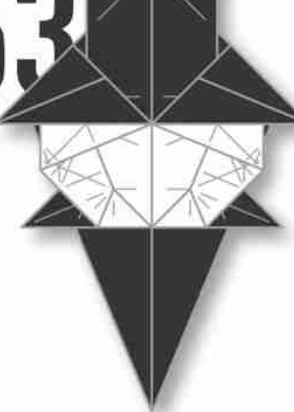

64

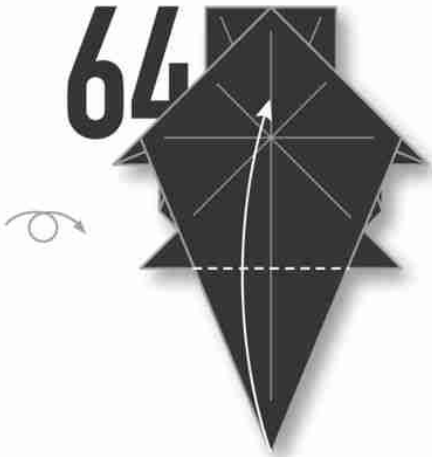

65

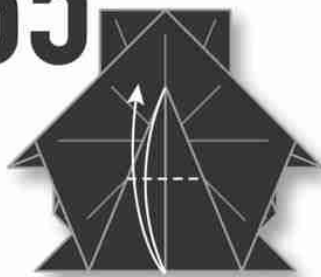

66



67



68

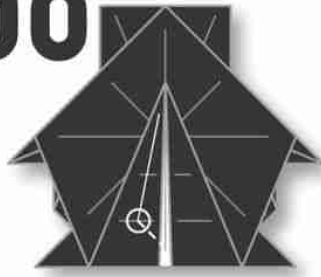

69



反対側も
67-68 と
同じように折る
Repeat steps 67-68 on the right.

COW



70
縁を広げながら
カドを下に折る
Fold down the corner
while opening the edges.



71
引き寄せる
ように折る
Swivel outside.



76
中割り折り
Inside
reverse fold.



77
中割り折り
Inside
reverse fold.

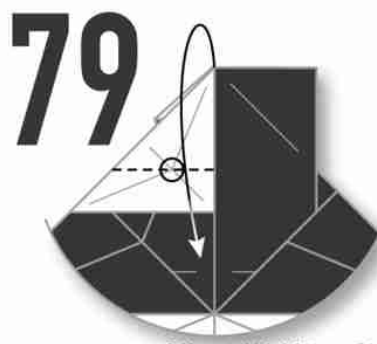

79
手前のカドを折り下げながら
起き上がってきた部分を潰すように折る
Fold down the top corner and squash.

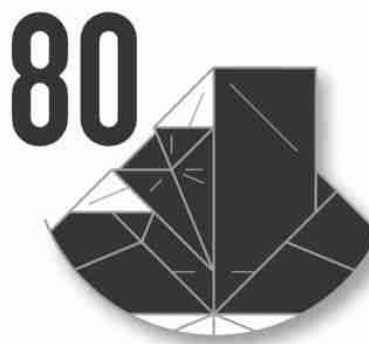

81
縁を引き寄せる
ように折る
Swivel outside.

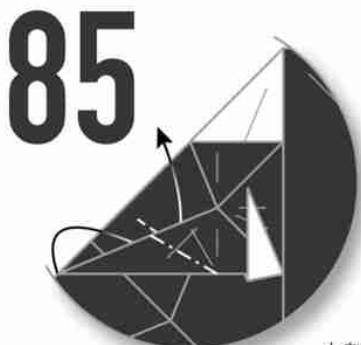
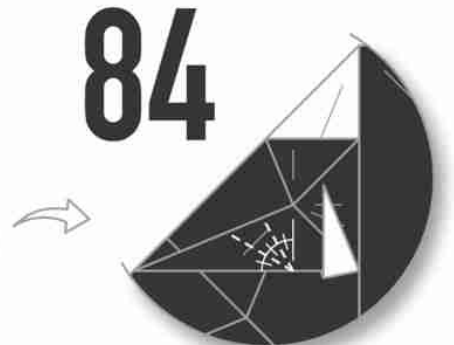

中割り折り
Inside
reverse fold.



手前の縁を折る
Fold the
top corner.



反対側も
73-87 と
同じように折る
Repeat steps
73-87 on the right.

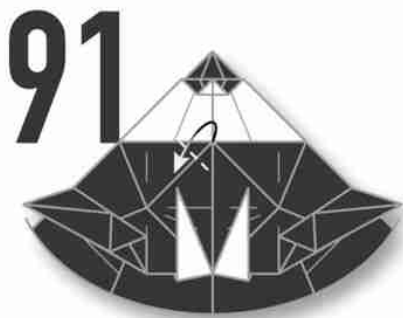
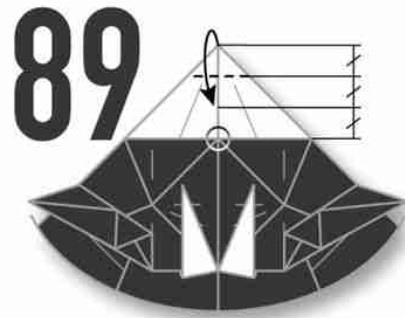

反対側も
91-92 と
同じように折る
Repeat steps
91-92 on the right.

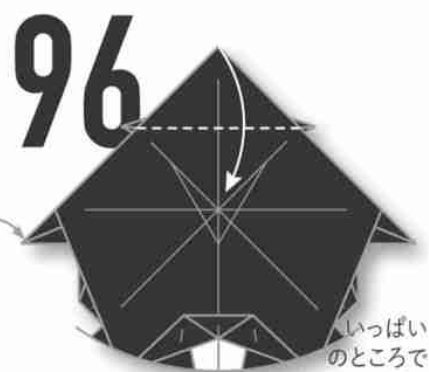
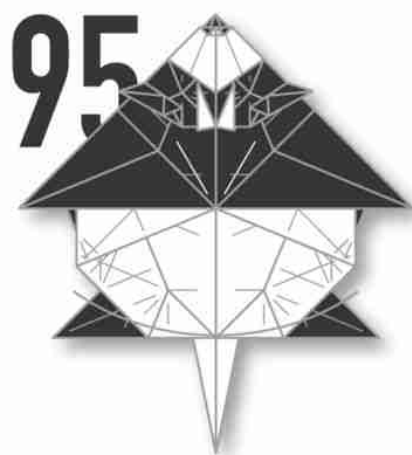

いっばいのところでカドを折り下げる
Fold down the corner all the way.



カドを下に引っ張り上のカドを潰して畳む
Pull down the corner and squash the top corner.

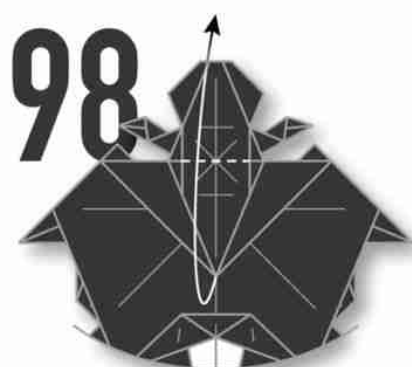

つけた折り筋で立体化
Make the model 3D using the crease lines.

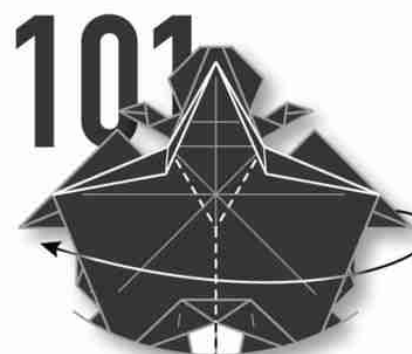

途中の図
In progress...



カドを隙間に差し込んで糊付けする
Insert the corners into the pockets and glue.

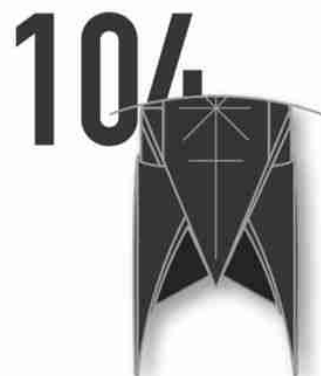

中割り折り
Inside reverse fold.

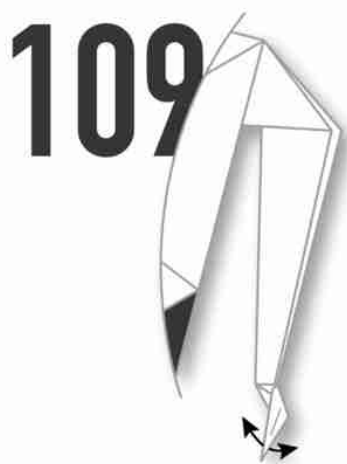
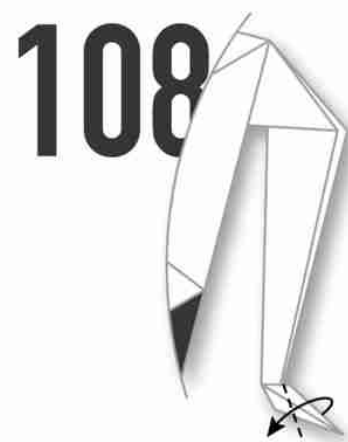
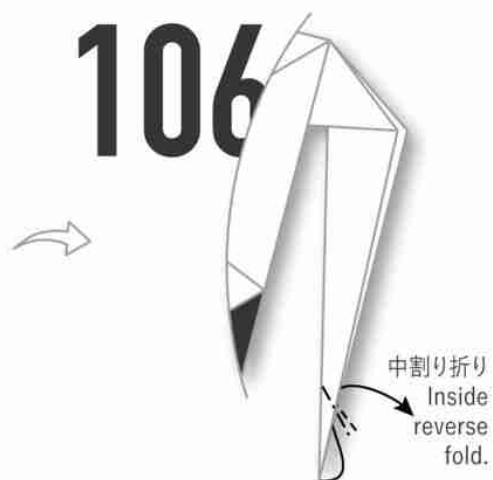

CROW

ORIGAMI MONO

カラス
2022



本書の表紙にカラスを使うことは、最初から決めていました。なぜなら、表紙に大きく「MONO」と表記することを決めており、カラス(CROW)と合わせて「モノクロウ」が完成するためです。こんな誰にも気づかれないダジャレのために創作しました。そして誰にも気づかれない哀しさを悟って、ここに書きました。また、こういう動機で生まれる作品があってもいいのではないかと思い、多様性のバランスを保つために身を切った次第です。

表紙に相応しいクオリティの作品にしなくてはいけないため、結構力を入れたつもりです。鶴の基本形から創作しています。

I had decided from the beginning to use crows on the cover of this book. This is because I have decided to write "MONO" on the cover, and "Mono-crow" will be completed together with the crow. I created this work for such a pun that probably no one notices. And I wrote this story here, realizing the sadness that no one notice. I also thought it would be good to have works created from this kind of motive, so I sacrificed myself to maintain a balance of diversity.

I've put a lot of effort into this work because I have to make it a best quality work suitable for the cover. Designed from the bird base.

24cm×24cm
COMPLEX

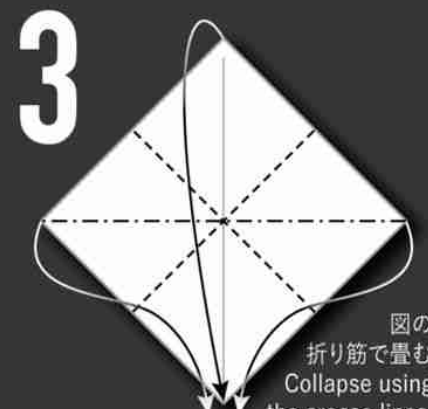
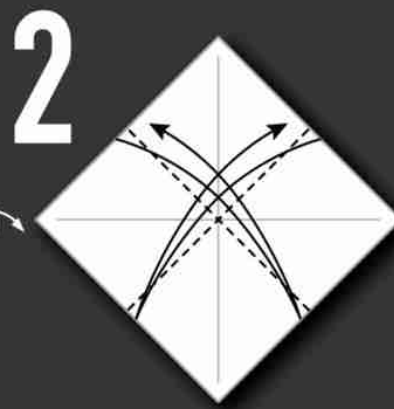
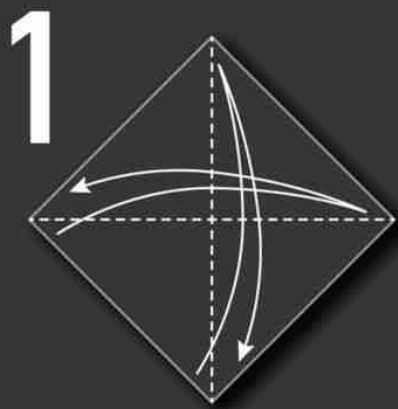
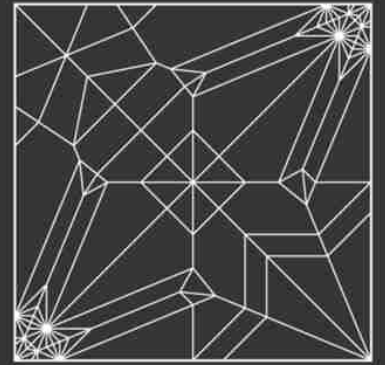

図の
折り筋で畳む
Collapse using
the crease lines.

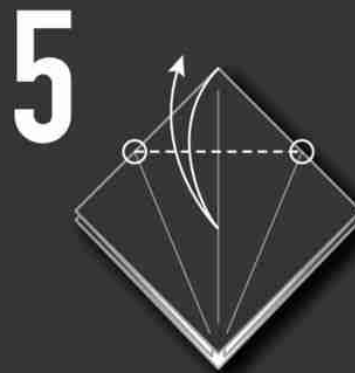
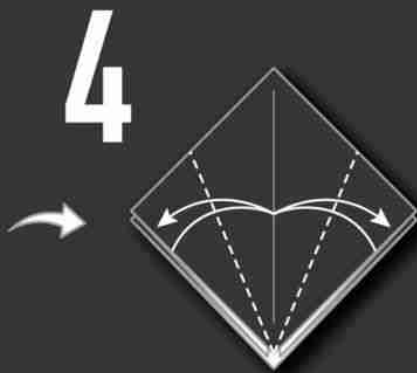

内側を広げて
潰すように折る
Open and squash.

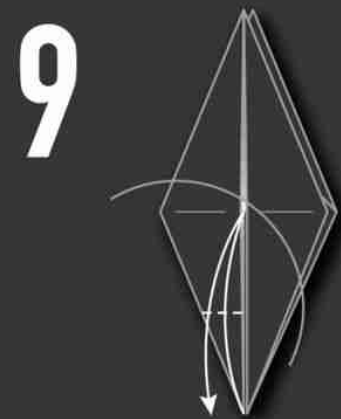
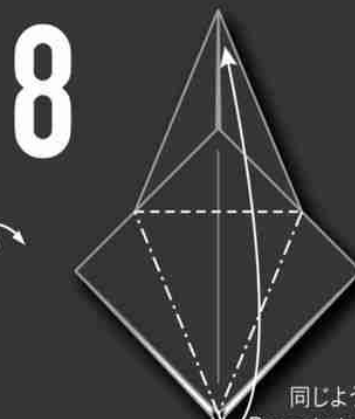

4-6 と
同じように折る
Repeat steps 4-6.

CROW

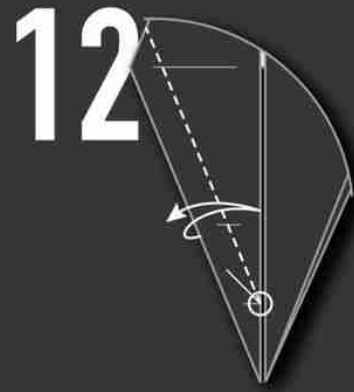
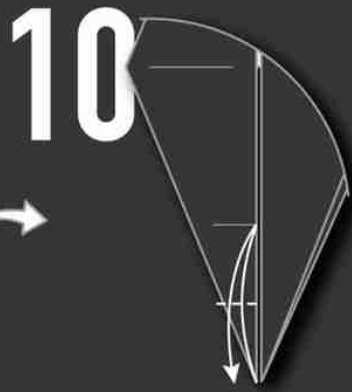

広げて
沈め折り
Open sink.

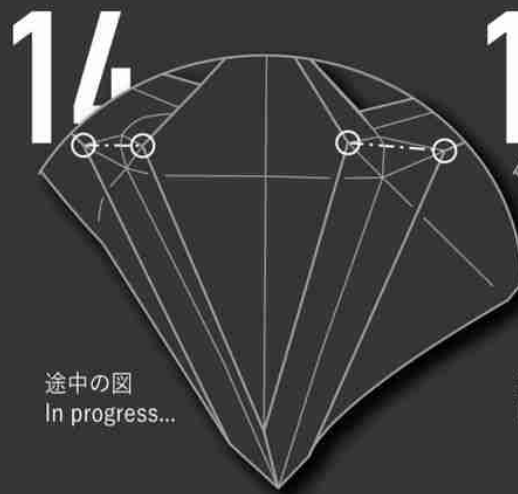

途中の図
In progress...

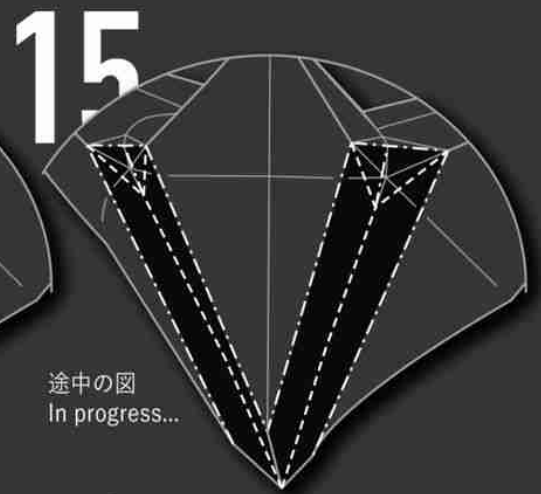

途中の図
In progress...

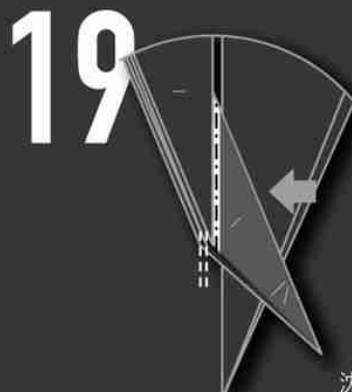

広げて
沈め折り
Open sink.





かぶせ折り
Outside
reverse fold.

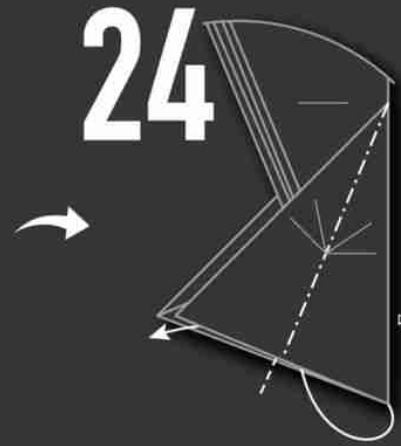

中割り折り
Inside
reverse fold.

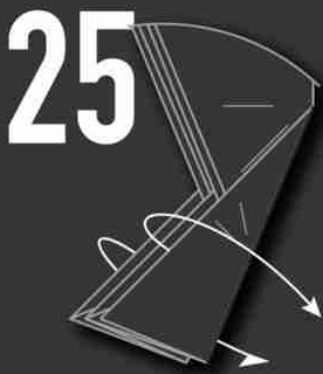

Re-crease the existing crease lines.



Rabbit ear fold and close the edges.



途中の図
In progress...



段折りを
引き下げる
Pull down
the pleats.



CROW

34

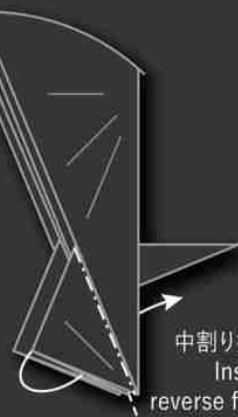

中割り折り
Inside
reverse fold.

35



中割り折り
Inside
reverse fold.

36

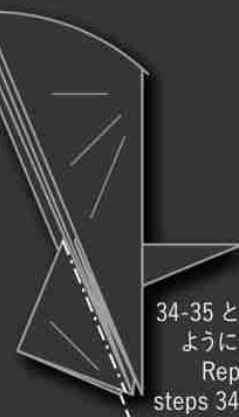

34-35と同じ
ように折る
Repeat
steps 34-35.

37



反対側も
9-36と同じ
ように折る
Repeat steps
9-36 on the right.

38

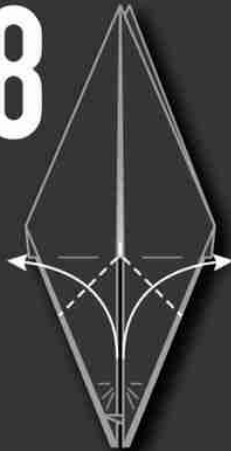

39

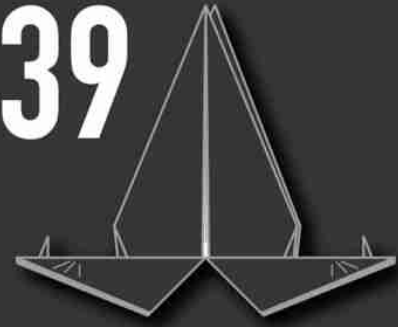

40

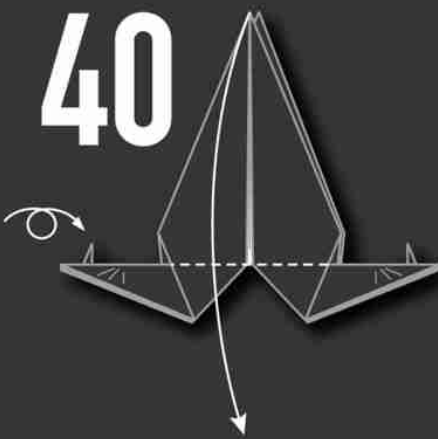

41



42



広げて
沈め折り
Open sink.

43



44



45



46

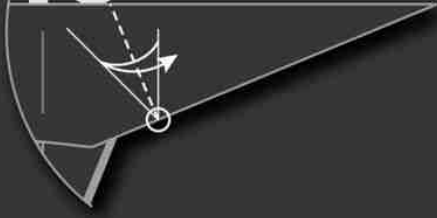

47

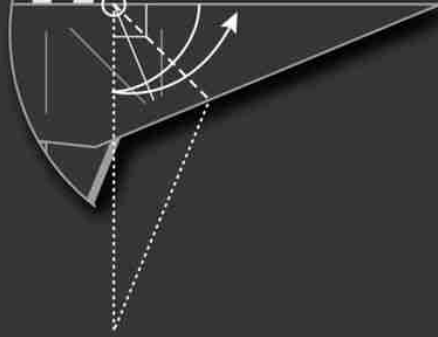

48

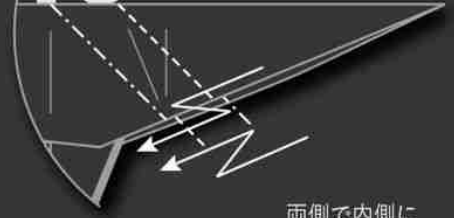

両側で内側に向かって段折り
Crimp inside.

49

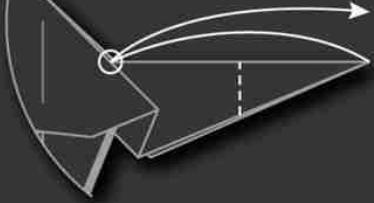

50

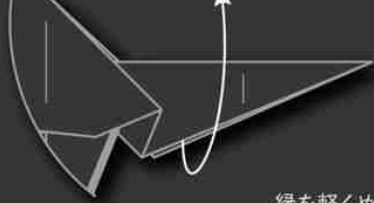

縁を軽くめくる
Open the edge lightly.

51

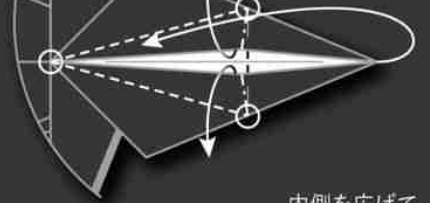

内側を広げて潰すように折る
Open and squash.

52

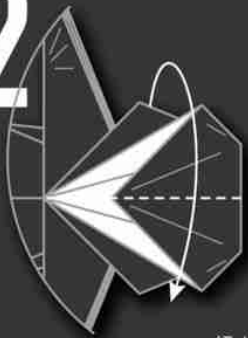

縁を閉じる
Close.

53

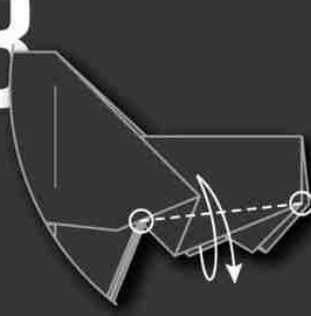

54

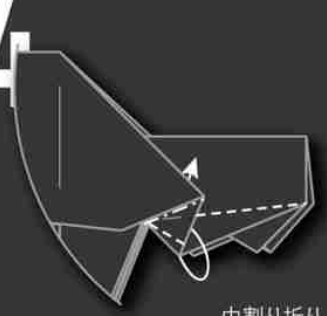

中割り折り
Inside reverse fold.

55

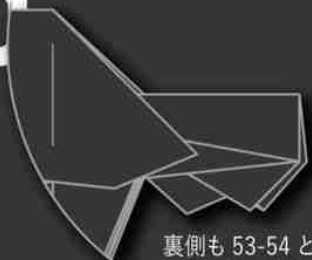

裏側も 53-54 と同じように折る
Repeat steps 53-54 behind.

56

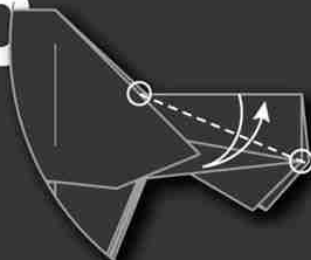

57

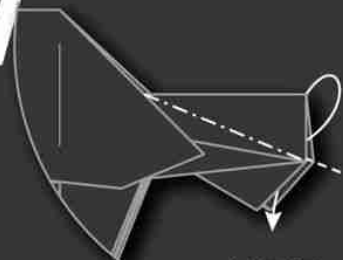

中割り折り
Inside reverse fold.

CROW

58

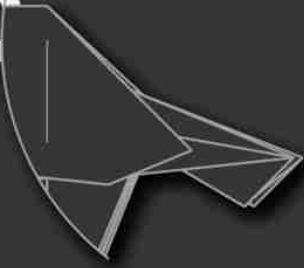

59

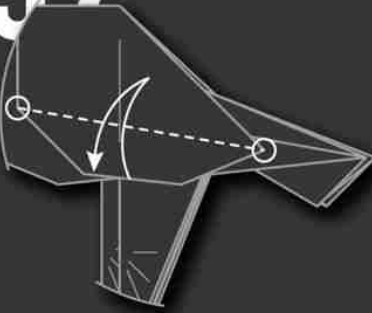

60

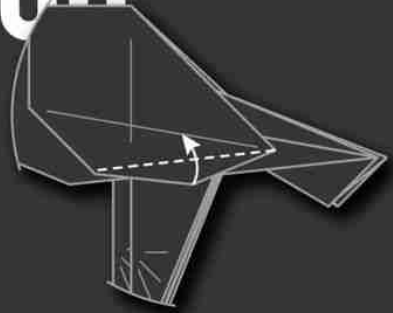

61

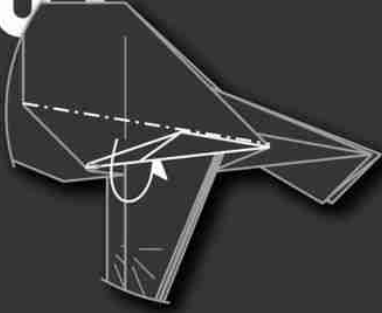

62



縁を軽くめくる
Open the
top edge lightly.

63

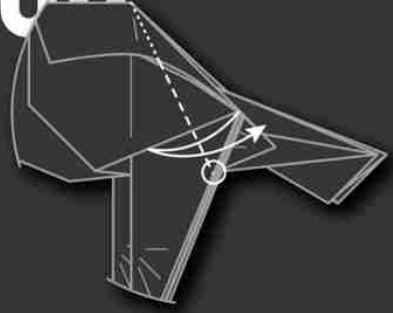

64



内側を広げて
潰すように折る
Open and squash.

65

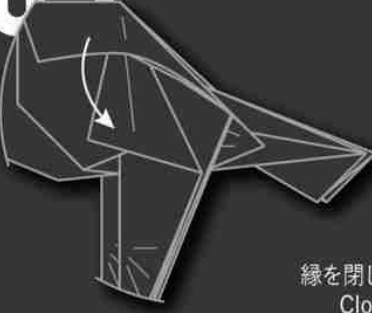

縁を閉じる
Close.

66

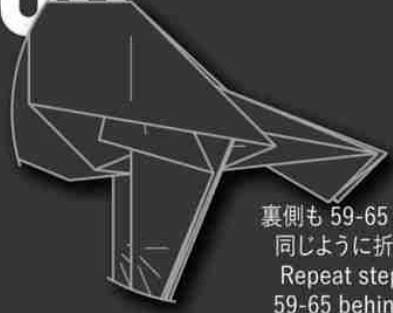

裏側も 59-65 と
同じように折る
Repeat steps
59-65 behind.

67

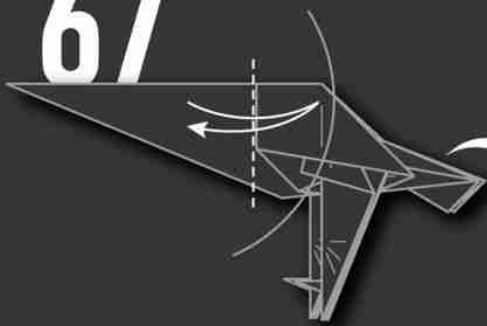

68

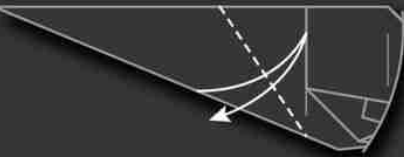

69

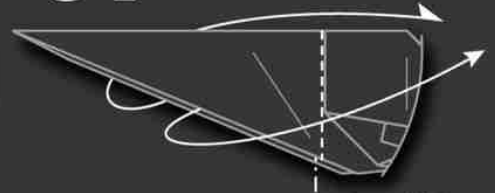

かぶせ折り
Outside
reverse fold.

70

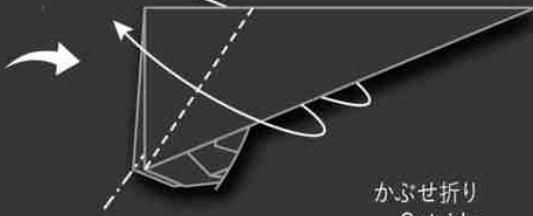

かぶせ折り
Outside
reverse fold.

71



両側で
内側の
カドを
引き出す
Pull out the
inner layers
on both sides.

72

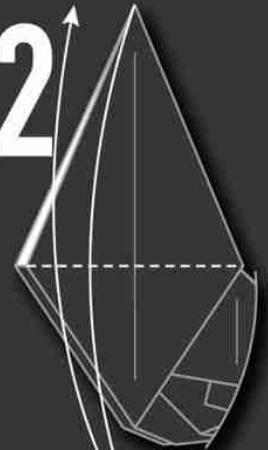

73

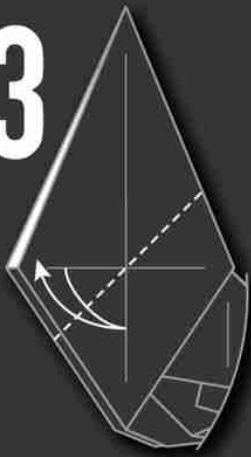

74



75



両側で
外側に
向かって段折り
Crimp outside.

76

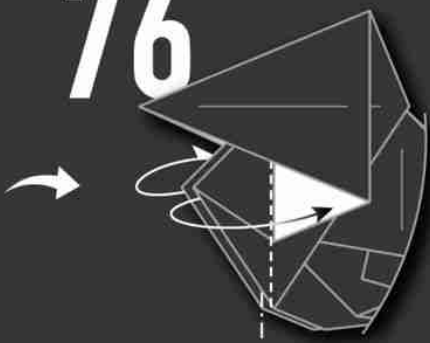

77

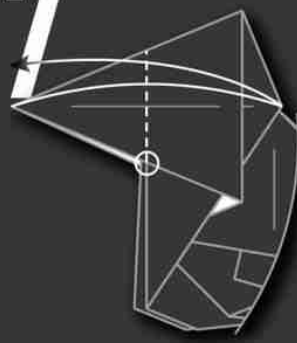

78

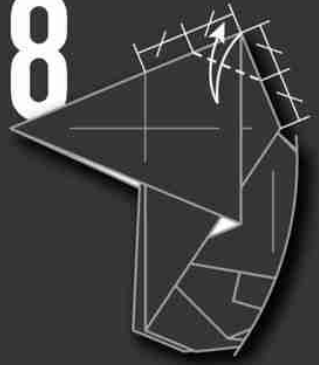

79



閉じたまま
沈め折り
Closed sink.

80



81

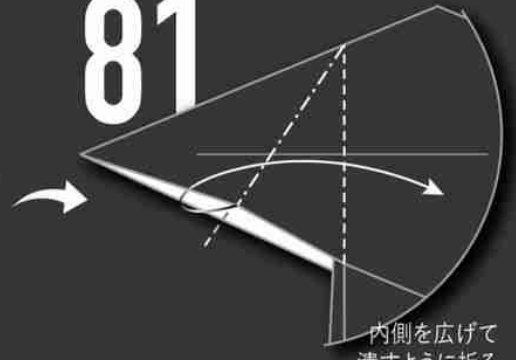

内側を広げて
潰すように折る
Open and squash.

CROW

82

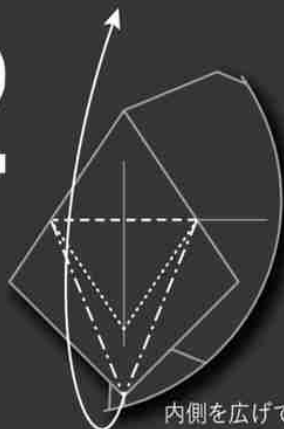

内側を広げて
潰すように折る
Open and squash.

83



84



85



カドを
つまむように折る
Rabbit ear fold.

86

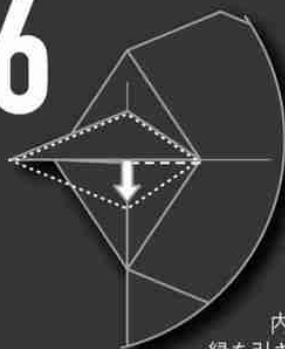

内側の
縁を引き出す
Pull out the inner layer.

87



88

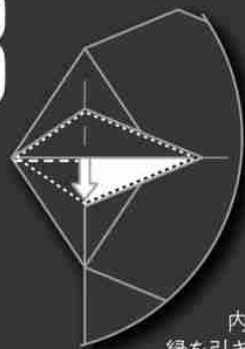

内側の
縁を引き出す
Pull out the inner layer.

89



90



91

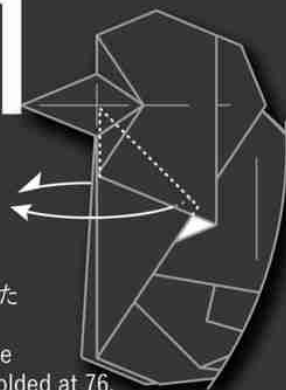

76で折った
縁を戻す
Unfold the
corners folded at 76.

92

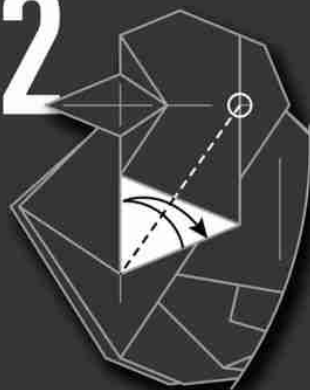

93



94

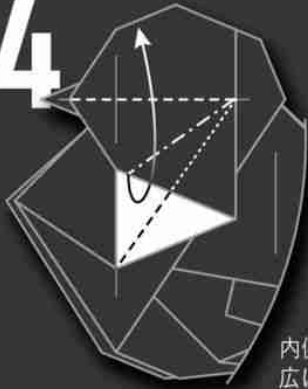

内側を
広げて
潰すように折る
Open and squash.

95



96

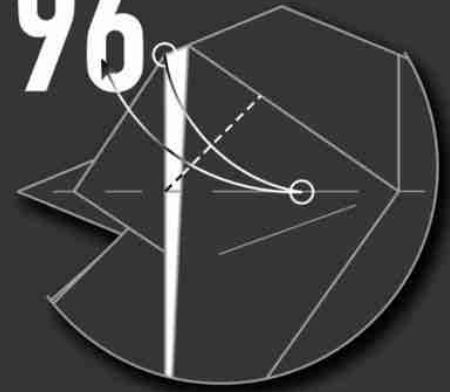

97



内側を
広げて
潰すように折る
Open and squash.

98

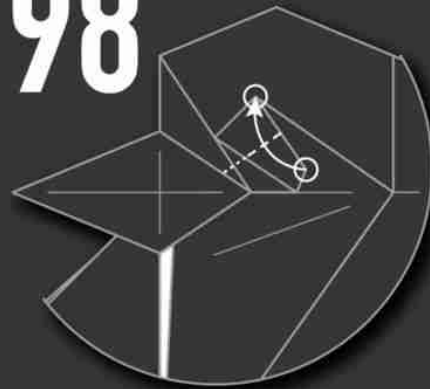

99



100



裏側も
92-99 と
同じように折る
Repeat steps 92-99 behind.

101



102



縁を
引き寄せる
ように折る
Swivel outside.

103



104



中割り
折り
Inside
reverse fold.

105



中割り
折り
Inside
reverse fold.

CROW

106



裏側も
101-105
と同じように折る
Repeat steps 101-105 behind.

107



108



109



縁を引き寄せる
ように折る
Swivel inside.

110



縁に沿って
折り筋をつける
Make a crease
along the edge.

111



図の位置で
折り筋をつける
Make a crease
as shown.

112



裏側も
108-111と
同じように折る
Repeat steps
108-111 behind.

113



全体を立体化
Make the model 3D.

114



完成
Model completed.

ZEBRA

ORIGAMI MONO

シマウマ
2015



ZEBRA

50cm×50cm

COMPLEX



2015年の作品です。それなりにバージョンアップを続けた末の作品ですが、今なお仕上げの再現が定まっています。初めてコンベンション折り図集に応募した作品であり、いきなり100工程超のしかも蛇腹作品を作図し世に出したということで、ある意味思い入れのある作品です。

糊付けと仕上げのゴリ押しが必要です。

当時のInkscapeデータを掘り起こし、Illustratorでの再編集も力尽くでした。

Made in 2015. Although it is the last work that has been upgraded, the reproduction of the finish is still not set in stone. This is the first work that I applied to the Origami Tanteidan Convention book, and I drew a box pleating work with more than 100 steps and released, so it's a work with a special feeling.

Gluing and shaping by force are required.

I dug up the Inkscape data at that time and re-edited it in Illustrator by force.

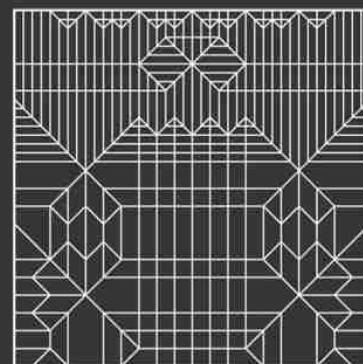

1



2

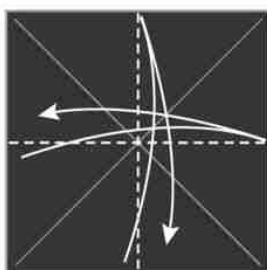

3

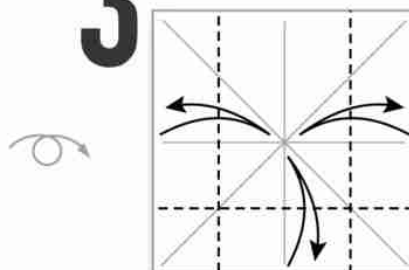

4

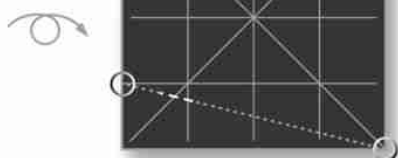

5

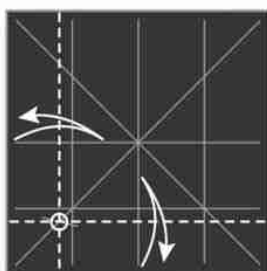

6

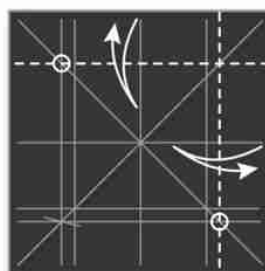

7

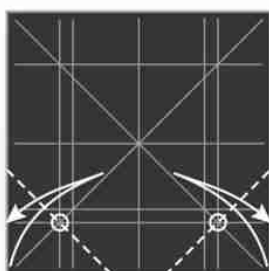

8

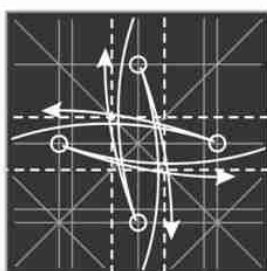

9

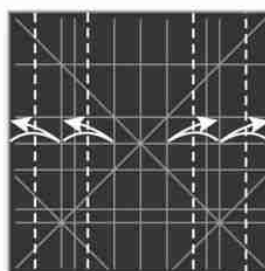

10

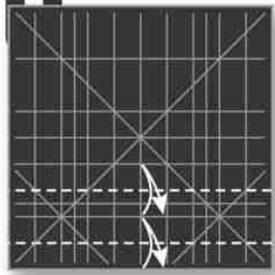

11

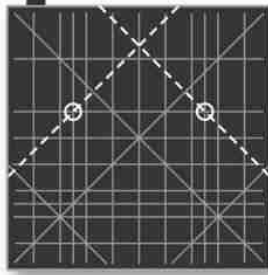

12

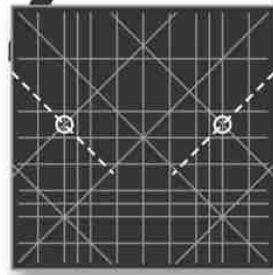

13

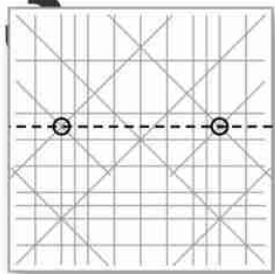

14

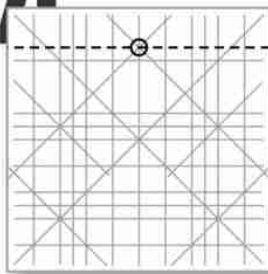

15

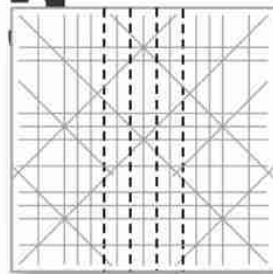

16

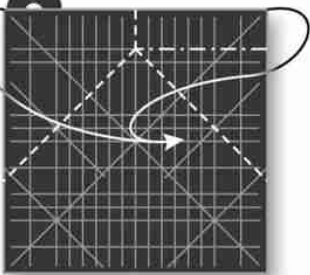

つまむ
ように折る
Rabbit ear fold.

17

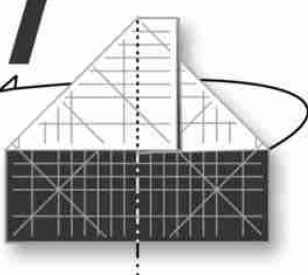

18

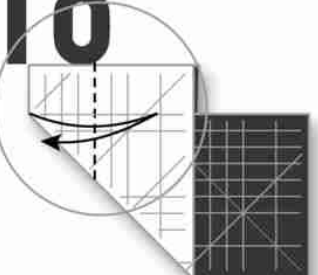

折り筋を
つけ直す
Re-create the
existing crease lines.

19

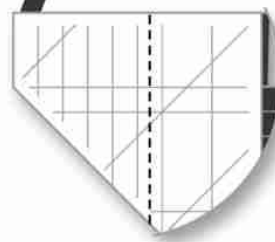

20

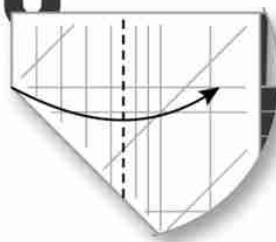

21

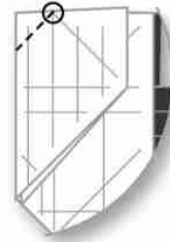

ZEBRA

22

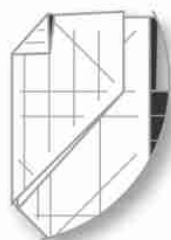

20 の状態に戻す
Unfold to step 20.

23

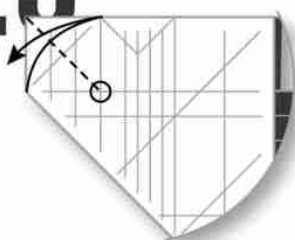

24

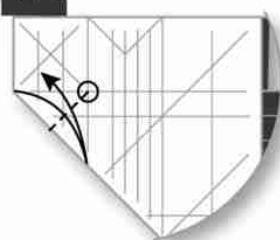

25

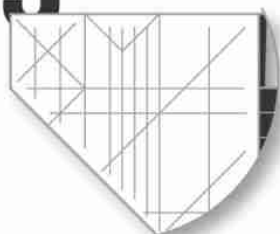

紙を全て広げる
Unfold everything.

26

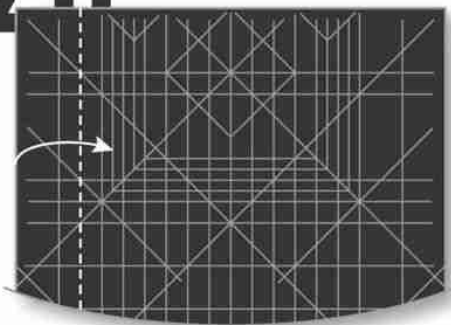

27

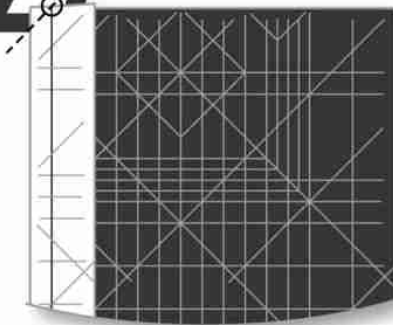

折り筋をつけて
紙を全て広げる
Make a crease and unfold everything.

28

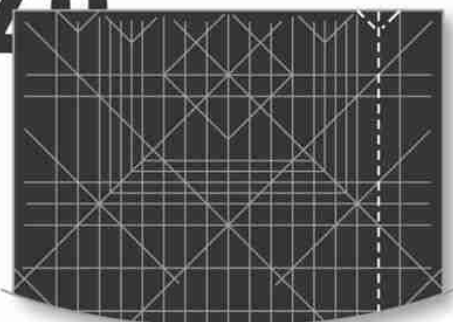

29

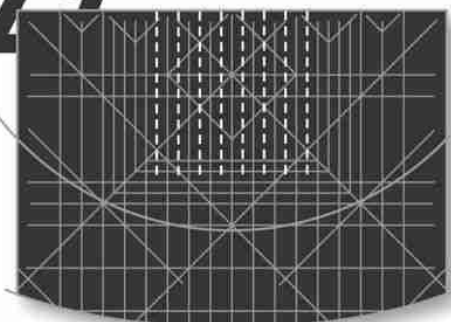

反対側も 26-27 と同じように折る
Repeat steps 26-27 on the right.

30

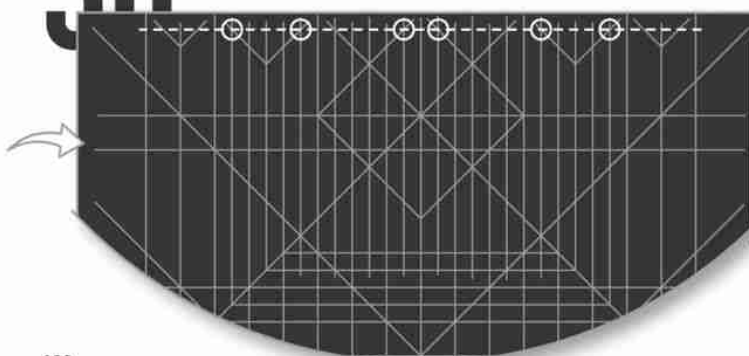

31

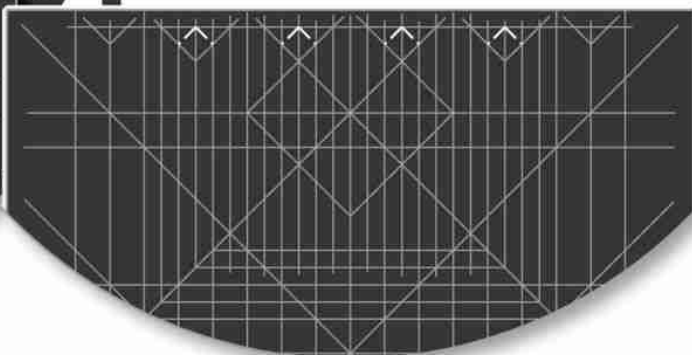

32

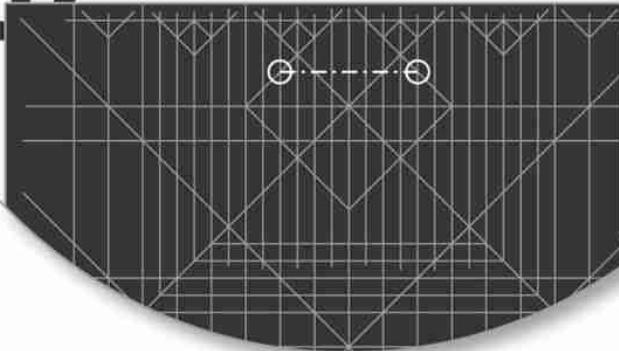

33

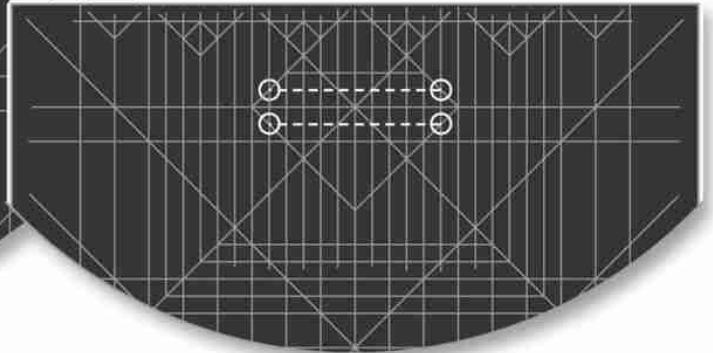

34

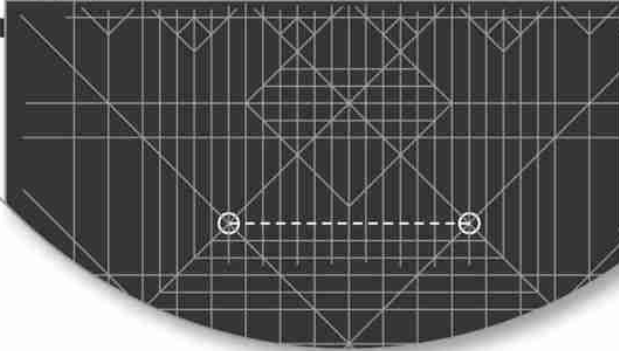

35

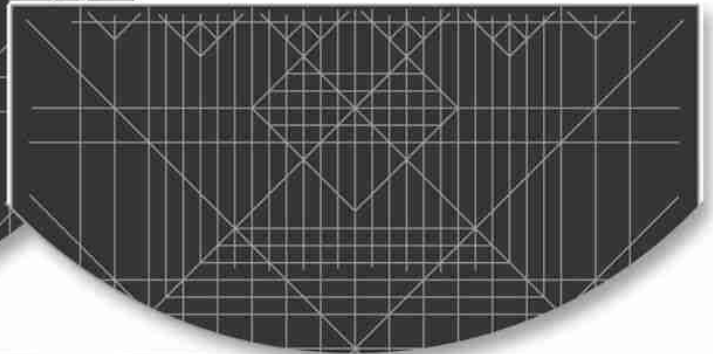

36

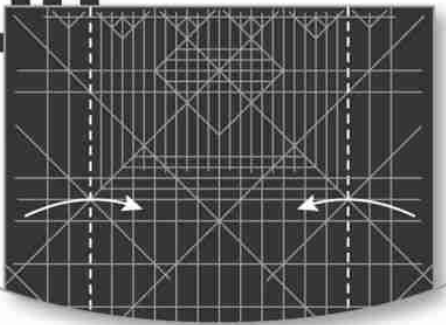

37

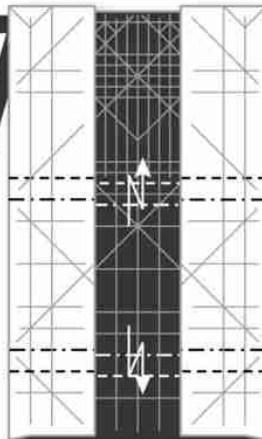

38

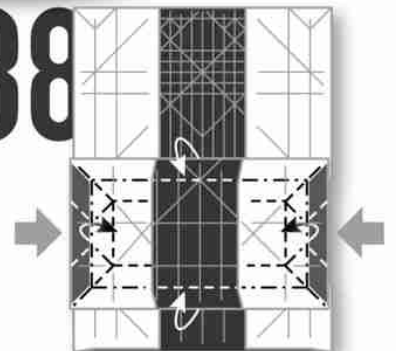

両縁を潰しながら引き寄せるように畳む
Squash the both edges and swivel fold.

39

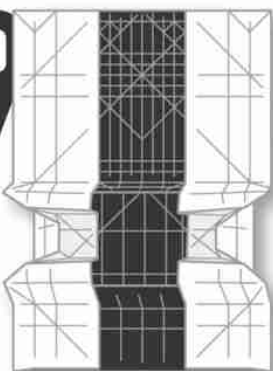

途中の図
In progress...

40

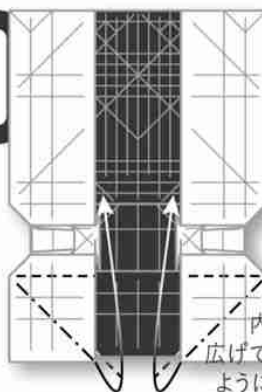

内側を
広げて潰す
ように折る
Open and squash.

41

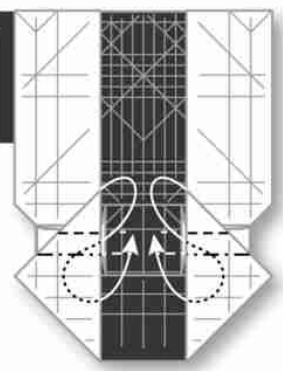

中割り折りを2回行う
Inside reverse fold twice.

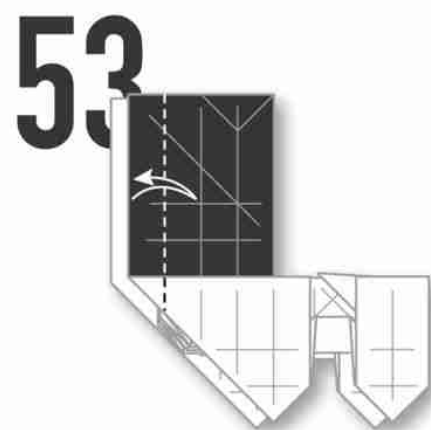
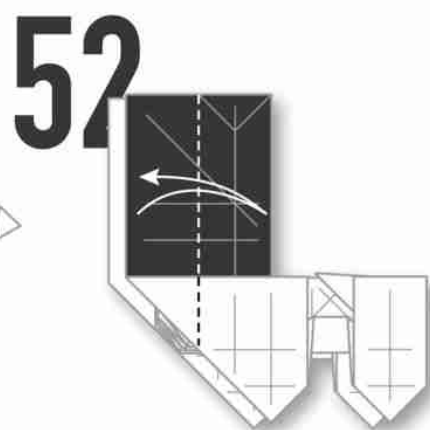
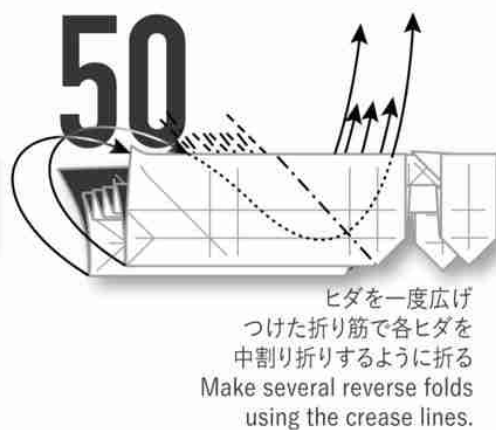
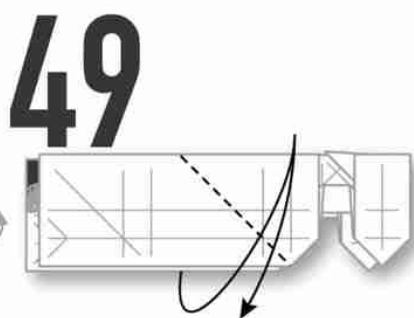
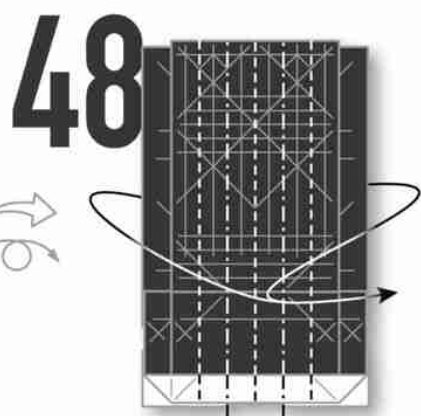
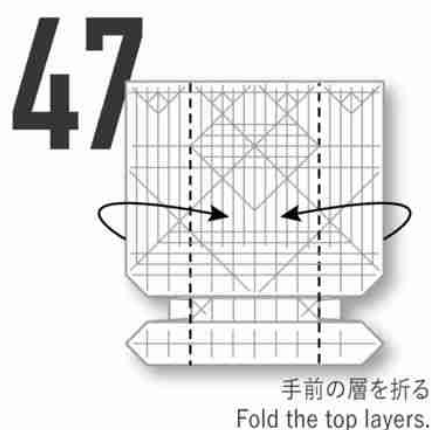
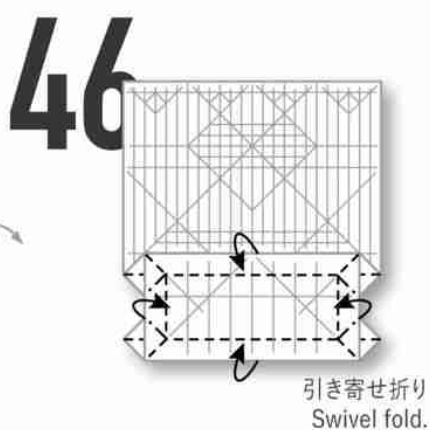
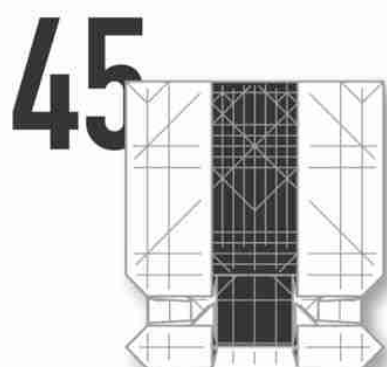
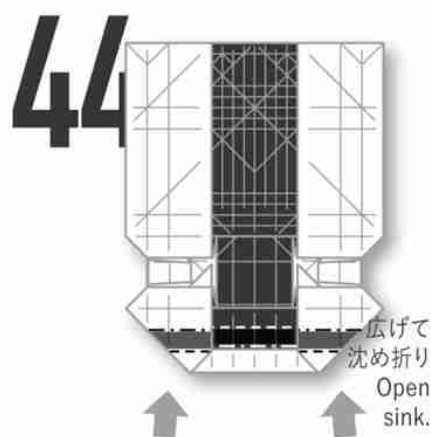
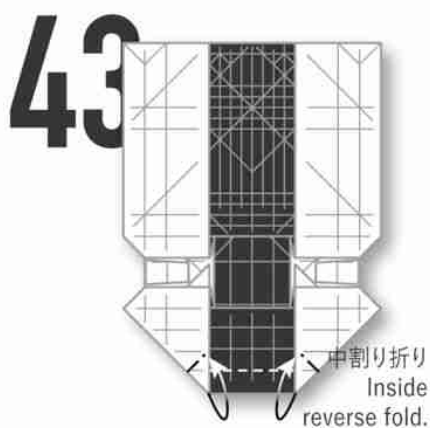
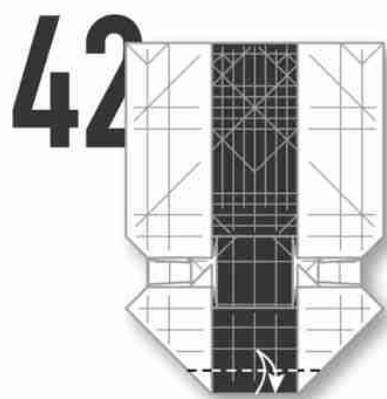

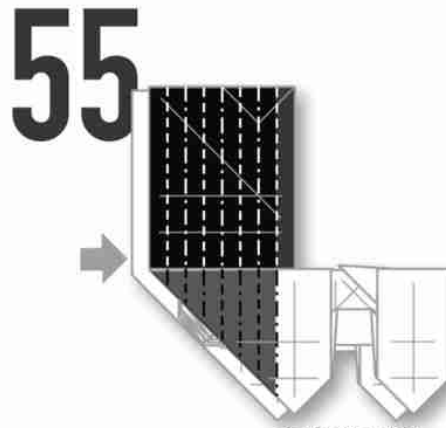
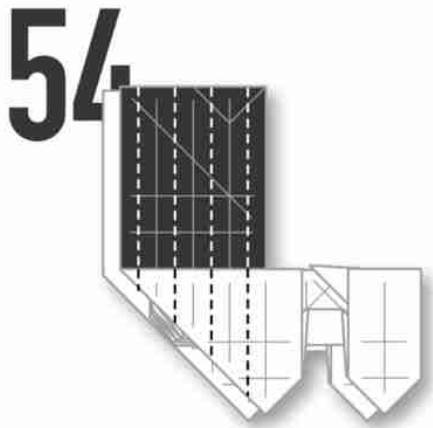

広げて沈め折り
Open sink.

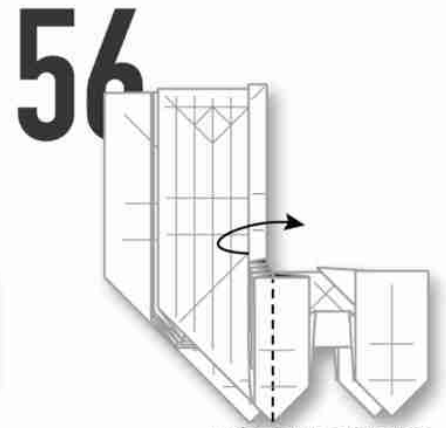

ヒダをまとめて右に折る
Fold the layers to the right.



裏側も 52-56 と同じように折る
Repeat steps 52-56 behind.

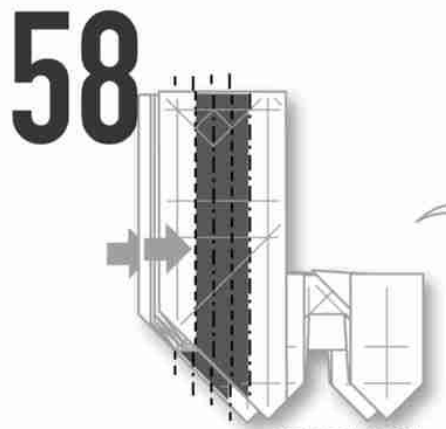

広げて沈め折り
Open sink.

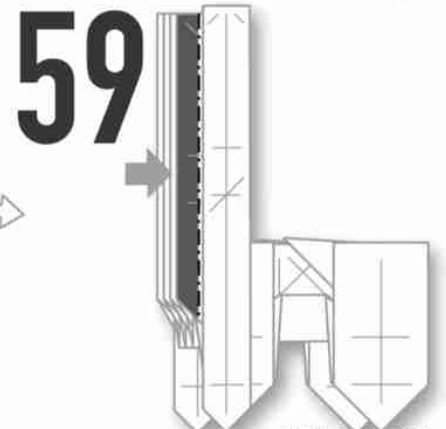

広げて沈め折り
Open sink.

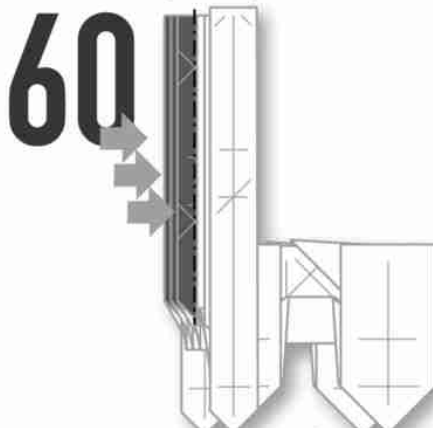

3回広げて沈め折り
Open sink three times.

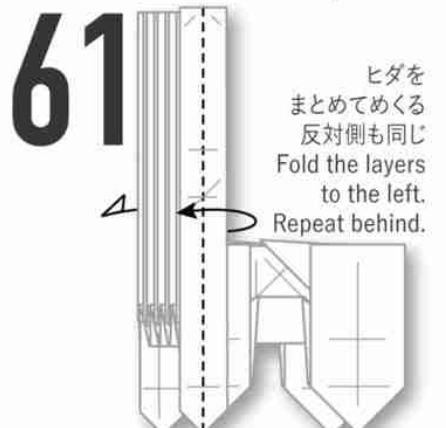

ヒダを
まとめてめくる
反対側も同じ
Fold the layers
to the left.
Repeat behind.

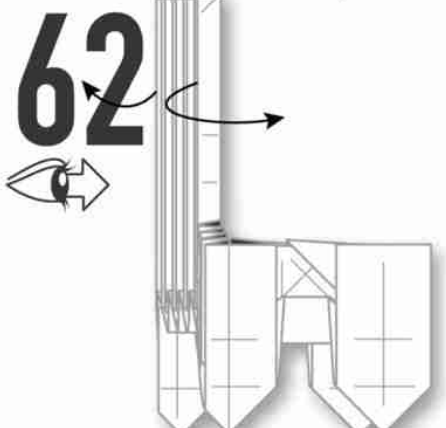

ヒダを広げる
Open the layers.

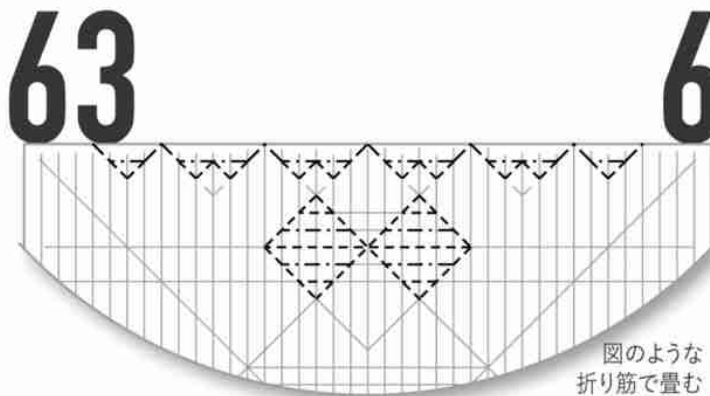

図のような
折り筋で畳む
Box-pleat as shown.

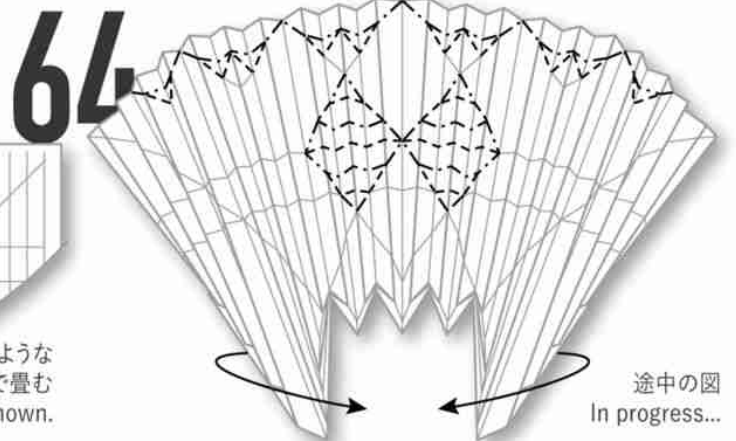

途中の図
In progress...

ZEBRA

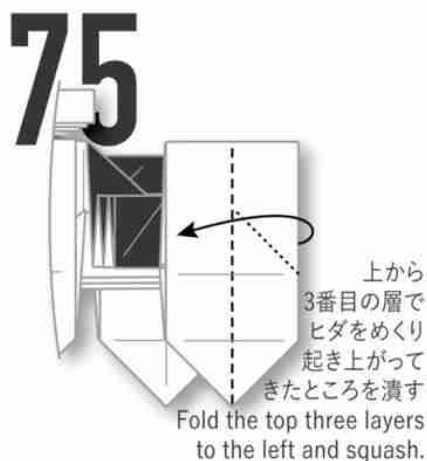
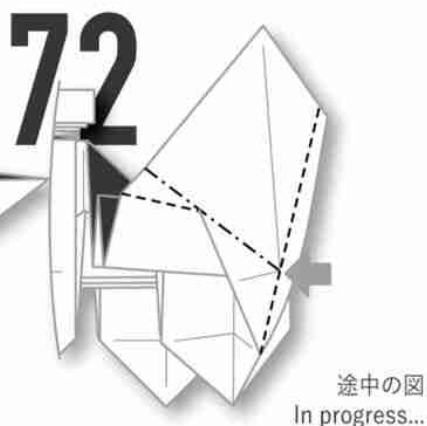
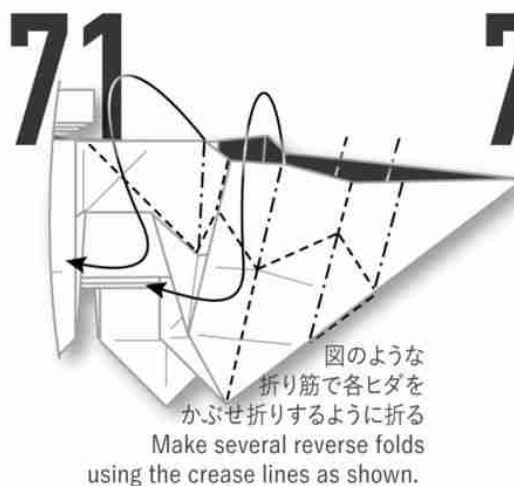
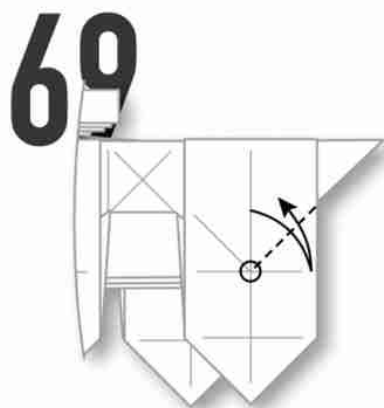
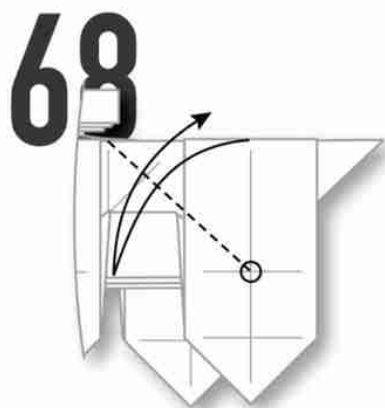
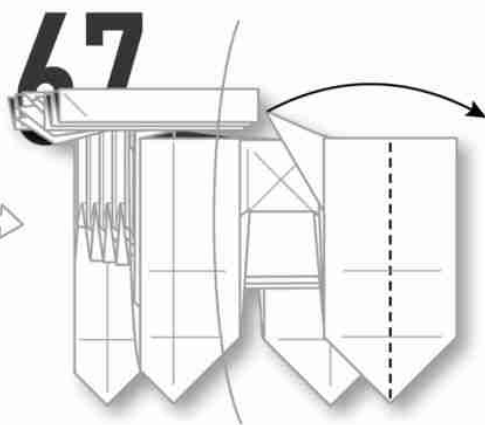
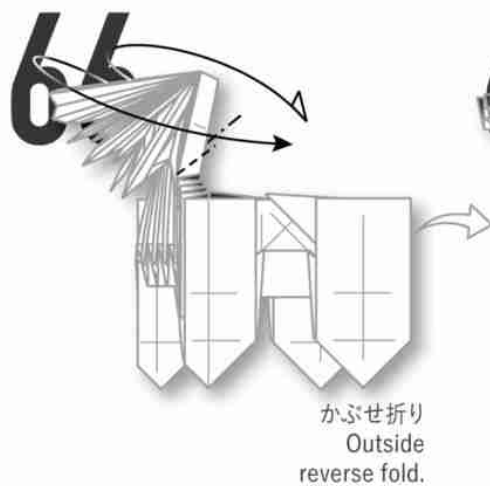
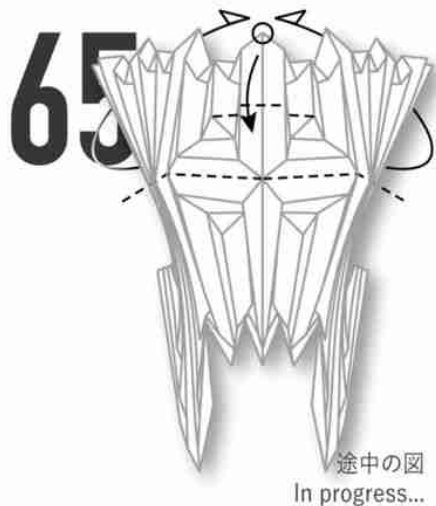

77

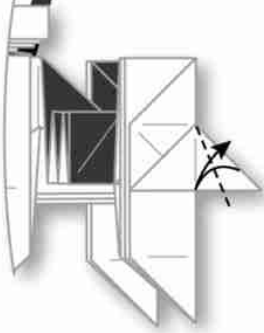

78

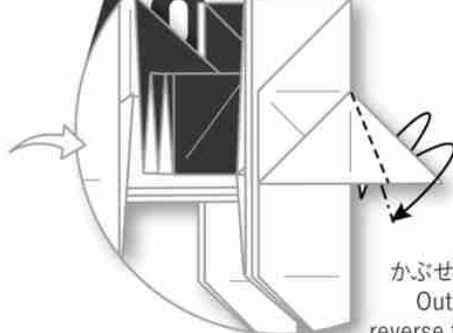

かぶせ折り
Outside
reverse fold.

79

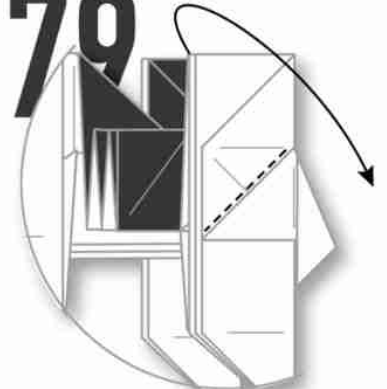

80

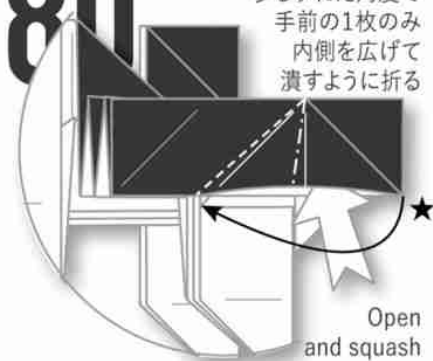

少しずれた角度で
手前の1枚のみ
内側を広げて
潰すように折る
Open
and squash
only the top layer
at a slightly off angle.

81

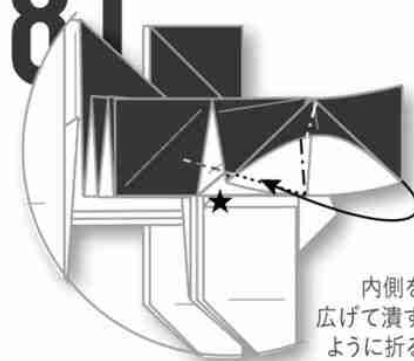

内側を
広げて潰す
ように折る
Open and squash.

82

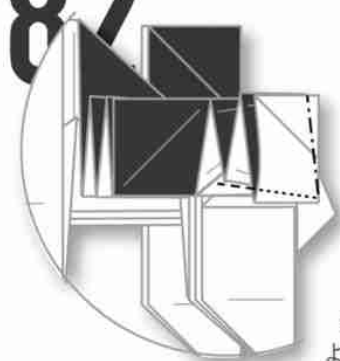

縞を作る
ように折る
Make stripes.

83

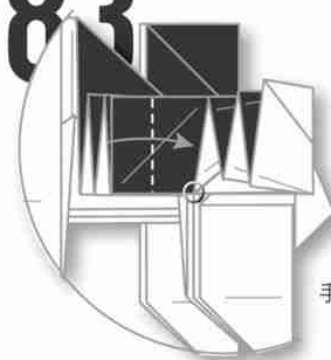

手前の1枚
のみ折る
Fold only
the top layer.

84

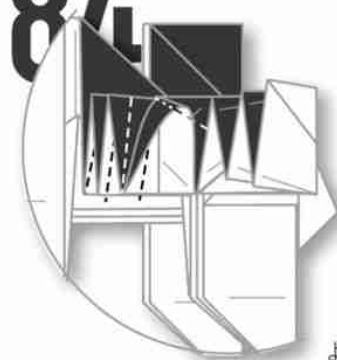

縞を作る
ように折る
Make stripes.

85

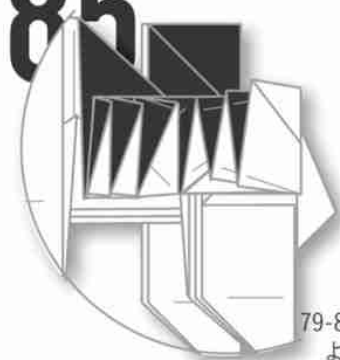

裏側も
79-84と同じ
ように折る
Repeat steps
79-84 behind.

86

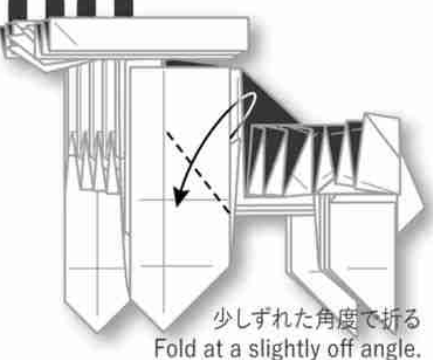

少しずれた角度で折る
Fold at a slightly off angle.

87

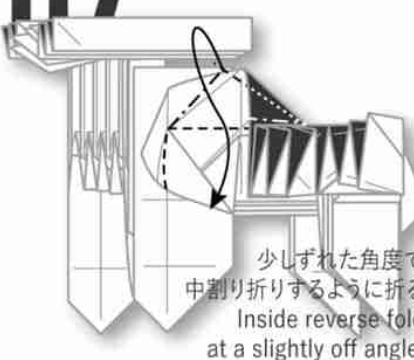

少しずれた角度で
中割り折りするように折る
Inside reverse fold
at a slightly off angle.

88

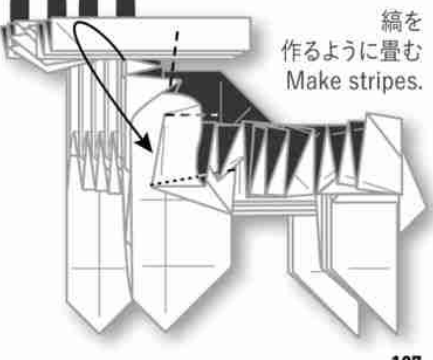

縞を
作るように
重ねる
Make stripes.

ZEBRA

89

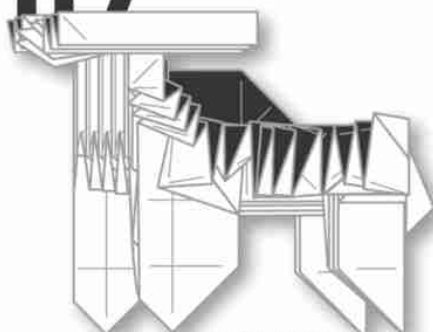

裏側も 86-88 と同じように折る
Repeat steps 86-88 behind.

90

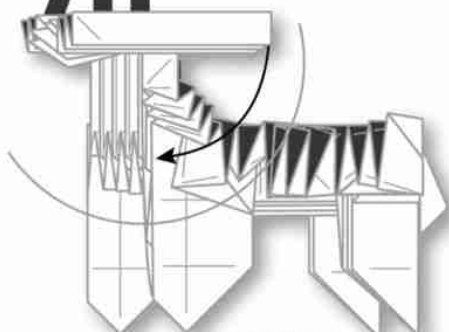

ヒダ6枚を15度ずつずらす
Rotate the six layers by 15 degrees.

91

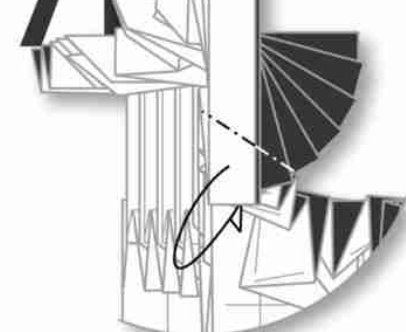

92



手前の
1枚のみめくる
Open only the top edge.

93



縞を作る
ように折る
Make stripes.

94



縞を作る
ように折る
Make stripes.

95

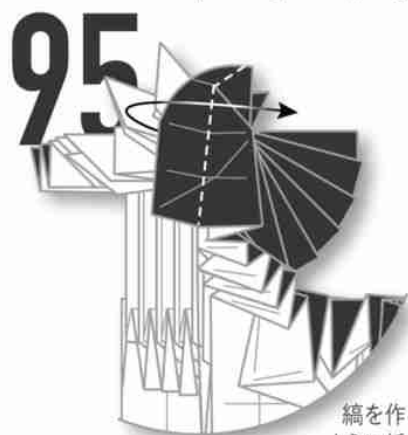

縞を作る
ように折る
Make stripes.

96



内側を
広げて
潰すように折る
Open and squash.

97



98



99



内側を
広げて潰すように折る
Open and squash.

100

