

**Meccanorigami
Tassellazioni
Decorazioni
Poliedri**

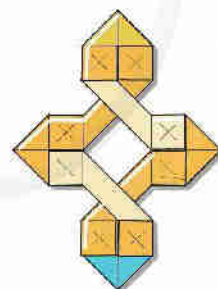

Franco Pavarin

www.aereimaschereorigami.altervista.org

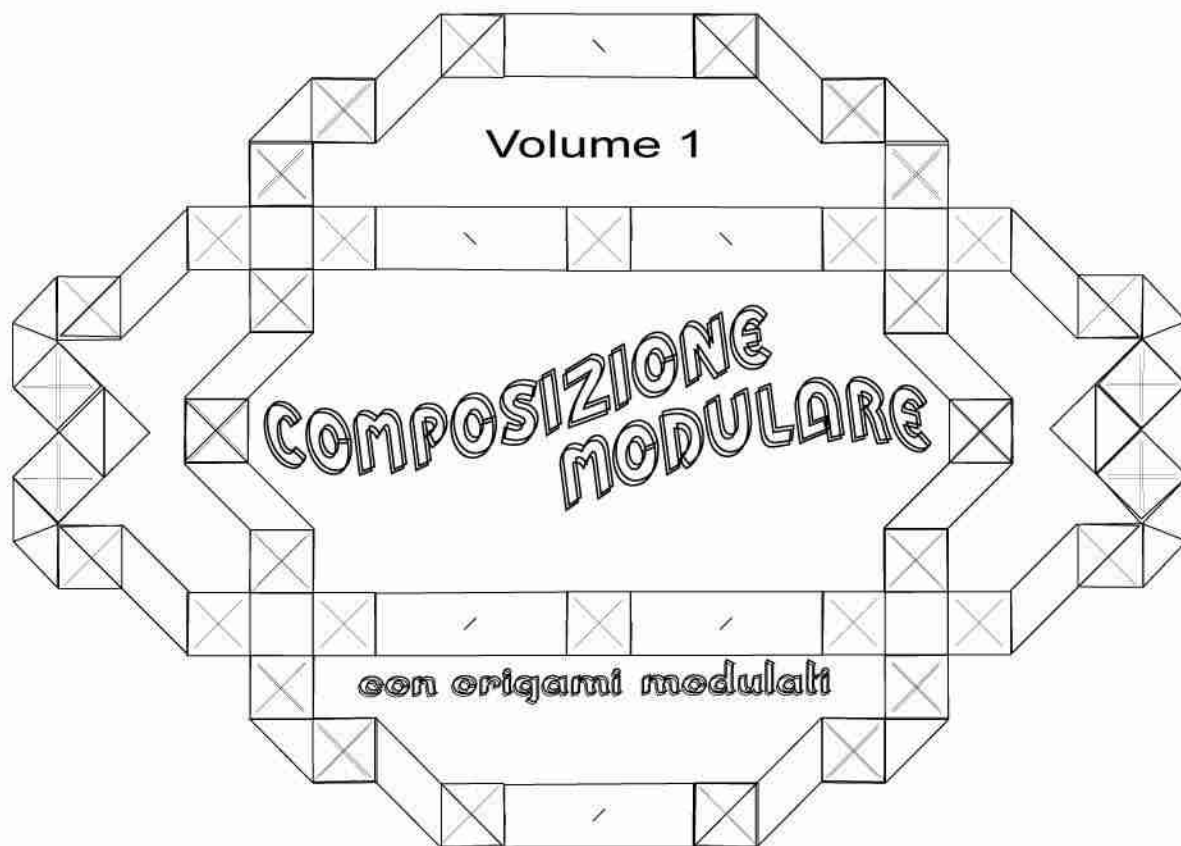

Franco Pavarin

www.aereimaschereorigami.altervista.com

Presentazione

Questo testo tratta di origami modulare, cioè della tecnica costruttiva di unione di moduli tutti uguali o anche di tipo diverso, ottenuti piegando fogli delle medesime dimensioni, per realizzare modelli origami piatti o tridimensionali.

Tale tecnica, sviluppata per prima da Tomoko Fuse diversi anni fa, consente di costruire quasi ogni tipo di modello, con un'incredibile varietà di possibili accostamenti cromatici.

L'origami tradizionale non può dare le opportunità che offre la tecnica modulare per sviluppare la creatività e la fantasia nella scelta del tipo di modulo, della forma della composizione e degli accostamenti di colore.

Questo testo, in gran parte basato su esperienze di diversi anni fa, può essere considerato una continuazione del mio vecchio libro: "Decorazioni modulari con origami modulati", in quanto intende fornire un contributo a coloro che lavorano con più persone organizzabili in gruppi di lavoro.

Gli ultimi due capitoli sono invece adatti per il piegatore più raffinato, puntiglioso e metodico, quello alla ricerca della migliore soluzione di un problema.

Meccanorigami deriva nel nome da un amato gioco della mia infanzia che consisteva nel collegare aste e piastre metalliche con viti e bulloni per realizzare ogni genere di veicoli.

Meccanorigami è un sistema basato su un particolare tipo di incastro, da me presentato ad un convegno CDO molti anni fa, ora ulteriormente perfezionato, che consente ad ogni modulo di unirsi con l'adiacente per mezzo di appendici che possono indifferentemente assumere la forma maschio o femmina. Con questo sistema si possono realizzare elaborate forme 2D come tassellazioni, cornici, nastri e pizzi o modelli tridimensionali di cui quelli presentati sono solo una parte.













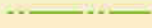













Questo sistema è anche ottimale per la costruzione di gioielli come ciondoli, orecchini e spille; da realizzare in carta metallizzata e da irrigidire con 2 o 3 bagni in liquido cristallizzante bicomponente.

In un testo successivo verranno presentati i risultati di un ulteriore sviluppo di "Meccanorigami", più altri sistemi di costruzione modulare 2D e 3D: "Ancora", "Cubotto" e "Intreccio".

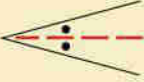
Aprile 2016

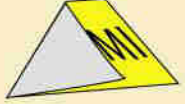
Franco Pavarin

Simbologia origami

		Indicazione	Risultato 3D
	Piega a valle (piega bassa)		
	Piega a monte (piega alta)		
	Ruotate e piegate		
	Ruotate, piegate e riportate alla posizione iniziale		
	Ribaltate sull'asse verticale		
	Ribaltate sull'asse orizzontale		
	Ruotate di 180°		
	Piega bisettrice a valle		
	Figura ingrandita		

Realizzazione delle pieghe rovesce

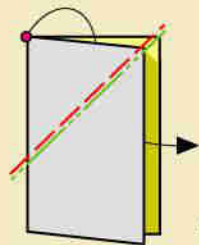

1

Eseguite una piega rovescia interna

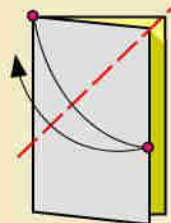

2

Una piega a valle

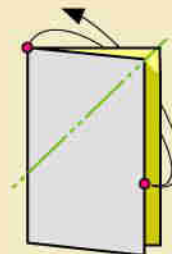

3

Ripiegate con piega a monte sulla medesima traccia

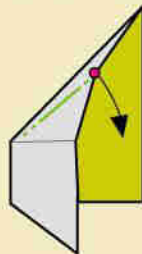

4

Aprite e rovesciate il verso della piega

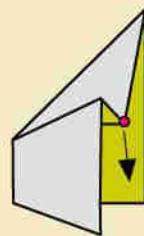

5

Inserite all'interno il vertice indicato

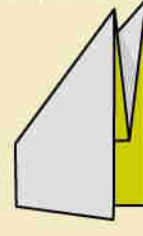

6

Piega rovescia interna ultimata

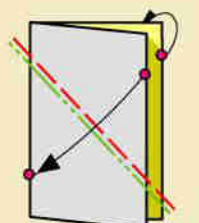

1

Eseguite una piega rovescia esterna

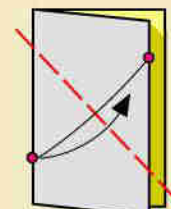

2

Una piega a valle

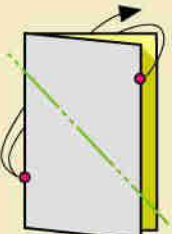

3

Ripiegate con piega a monte sulla medesima traccia

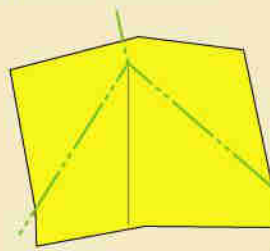

4

Aprite e rovesciate il verso della piega

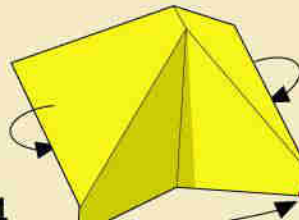

5

Richiudete

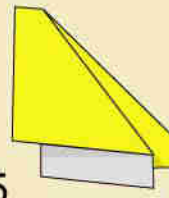

6

Piega rovescia esterna ultimata

TASSELLAZIONE MODULARE MULTIFORME

CLASSIFICAZIONE TIPOLOGICA



A

pg

8

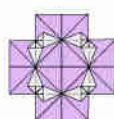

H

pg

16

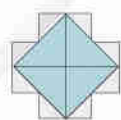

B

10

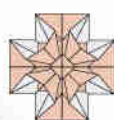

I

17

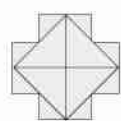

C

11

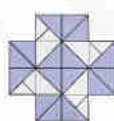

L

19

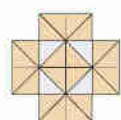

D

12

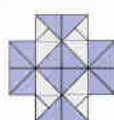

M

19

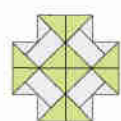

E

13

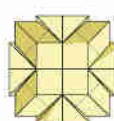

N-3D

20

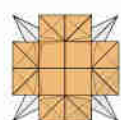

F

14

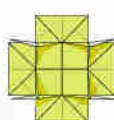

O-3D

21

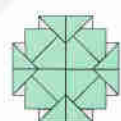

G

15

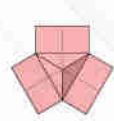

P-3D

22

TASSELLAZIONE MODULARE MULTIFORME

...è un sistema costruttivo per la realizzazione di tassellazioni con origami modulati che permette centinaia di combinazioni.

I 52 moduli presentati sono tutti collegabili tra loro e cambiando il tipo di sovrapposizione è possibile creare moltissime trame differenti.

Le 18 composizioni riportate in fotografia, da me realizzate una ventina d'anni fa, sono state ottenute unendo moduli solamente di tipo A, B e C.

Una volta ultimata la tassellazione, piegate tutti gli angolini sottostanti dei moduli perimetrali.

Può essere adoperata carta di qualunque tipo; consiglio l'uso del ferro da stiro per spianare adeguatamente la composizione ultimata.

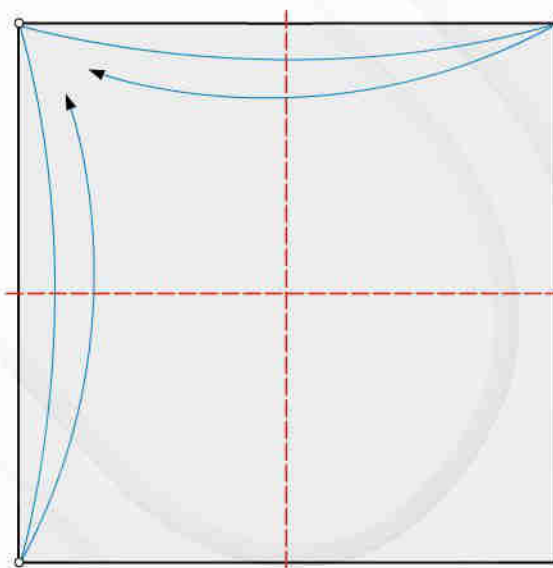

2 pieghe a valle

1

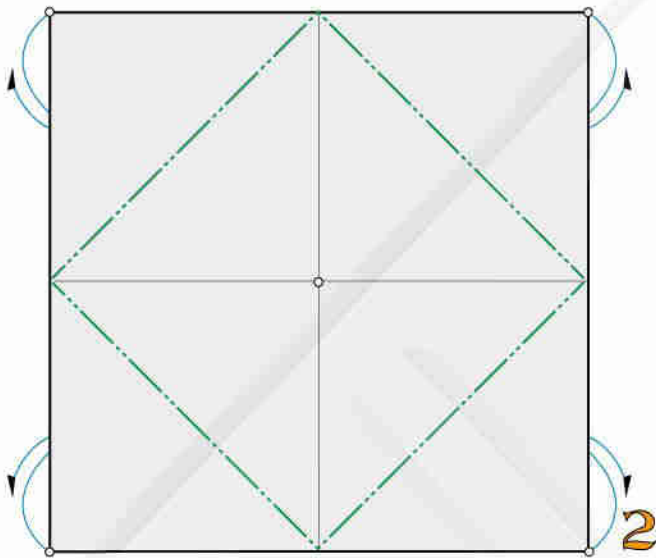

4 pieghe a monte

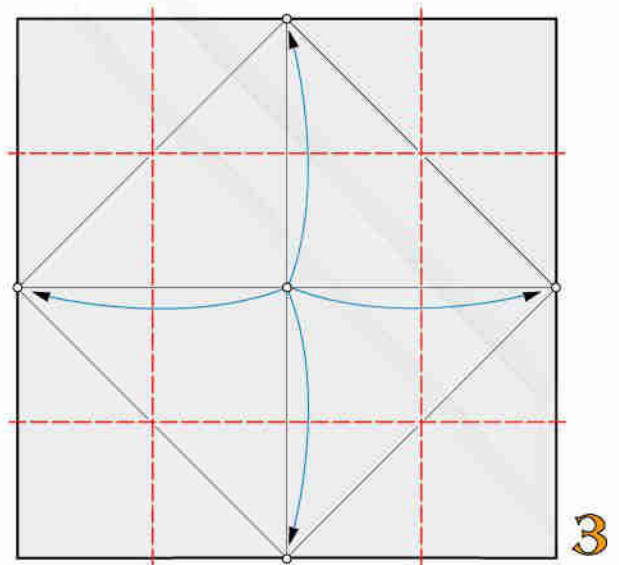

4 pieghe a valle e ruotate portando al centro i punti medi

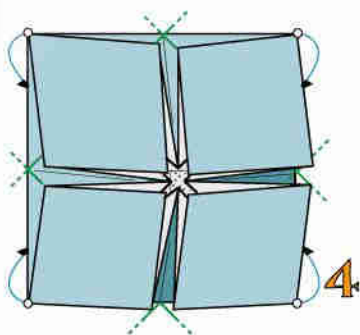

4 pieghe a monte e ruotate portando posteriormente i vertici al centro

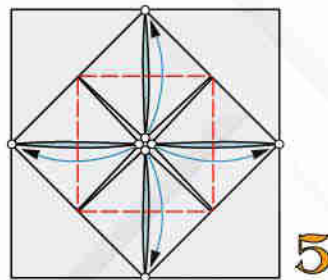

4 pieghe a valle e ruotate i vertici centrali

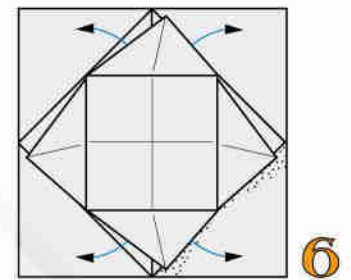

Estraete le superfici triangolari sottostanti ai vertici

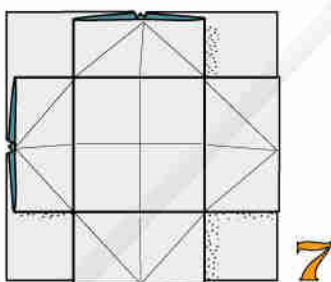

Ribaltate

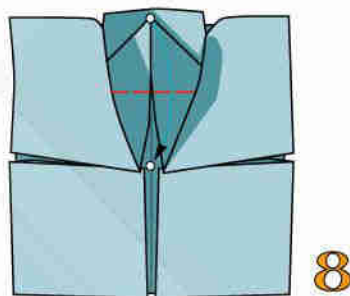

4 pieghe a valle nascoste e ruotate portando al centro i 4 vertici centrali

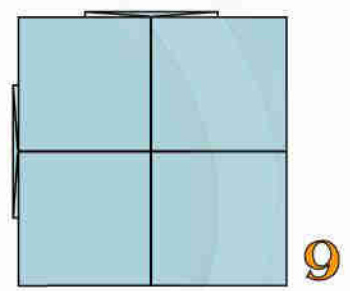

Modulo base ultimato

A

MODULI ULTIMATI

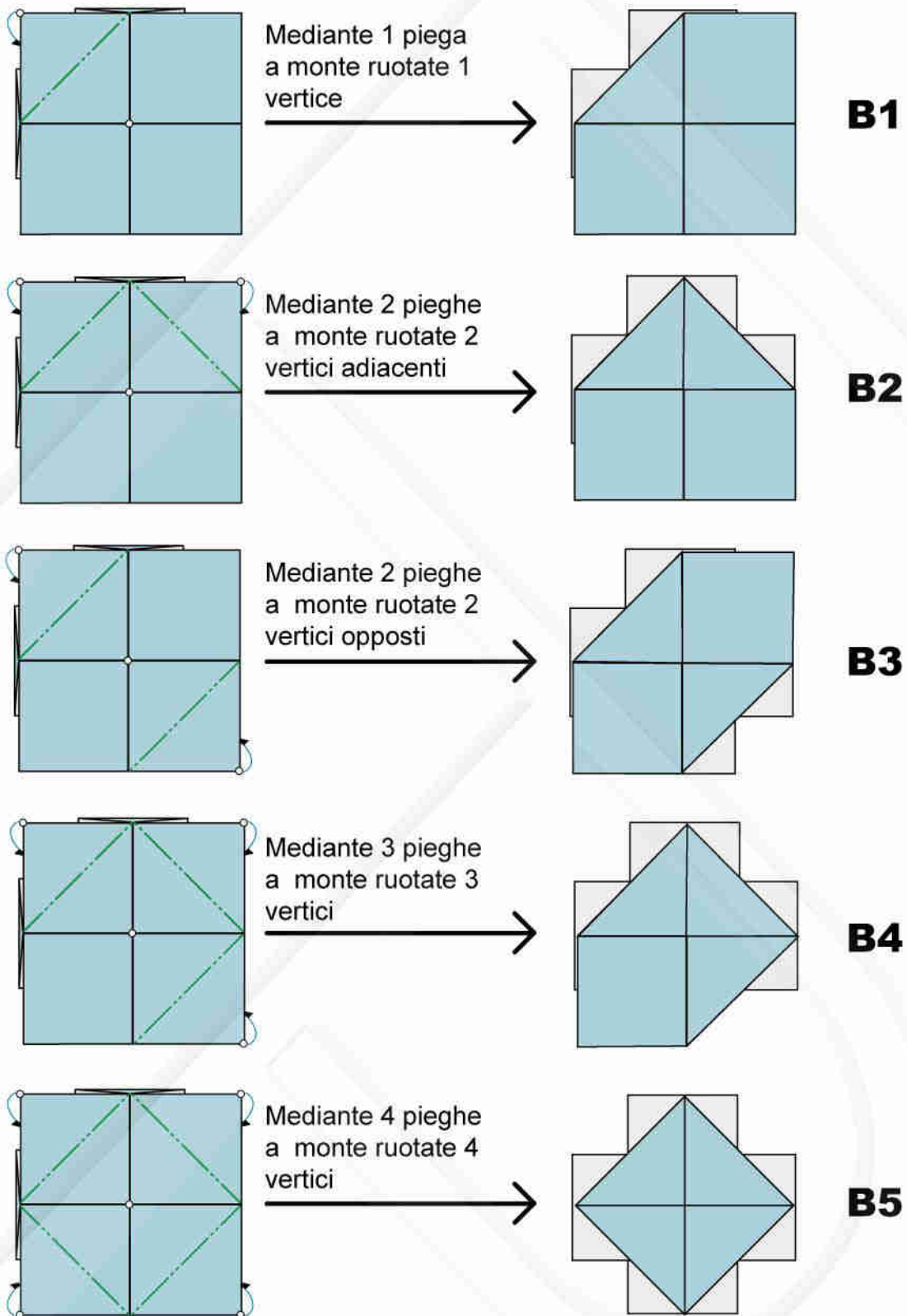

MODULI ULTIMATI

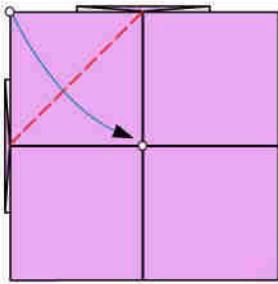

Mediante 1 piega
a valle ruotate 1
vertice

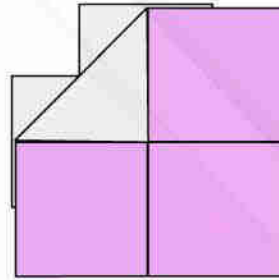

C1

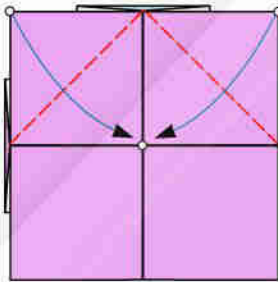

Mediante 2 pieghe
a valle ruotate 2
vertici adiacenti

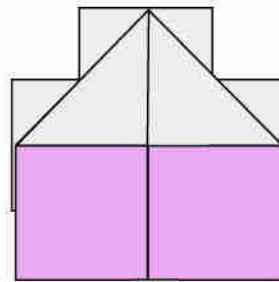

C2

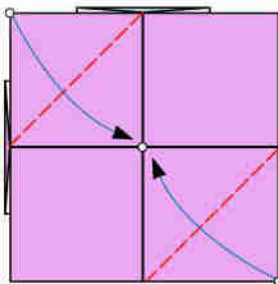

Mediante 2 pieghe
a valle ruotate 2
vertici opposti

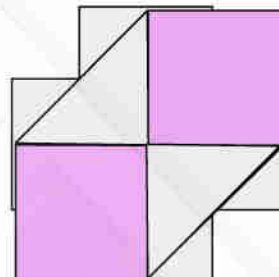

C3

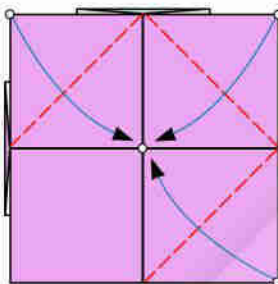

Mediante 3 pieghe
a valle ruotate 3
vertici

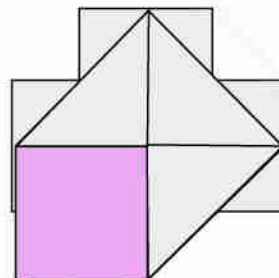

C4

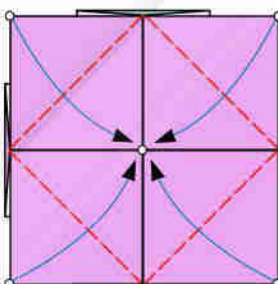

Mediante 4 pieghe
a valle ruotate 4
vertici

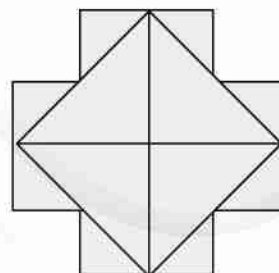

C5

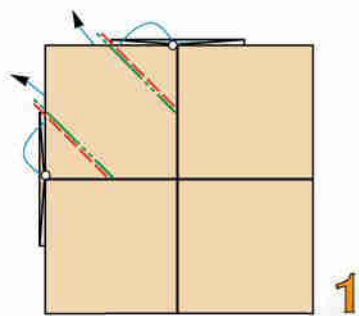

2 pieghe rovesce interne

1

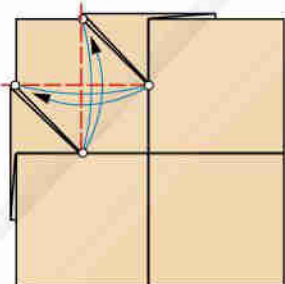

2 pieghe a valle

2

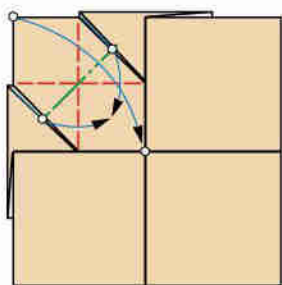

1 piega a monte e ruotate ripiegando a valle

3

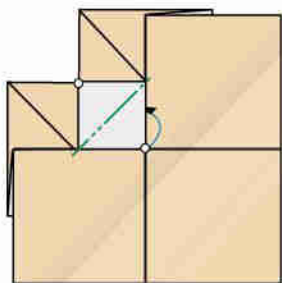

1 piega a monte e ruotate intascando

4

MODULI ULTIMATI

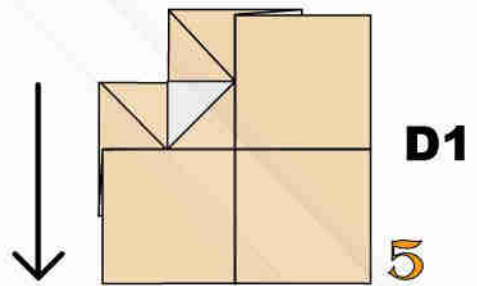

D1

5

Ripetete la sequenza di pieghe per 2 vertici adiacenti

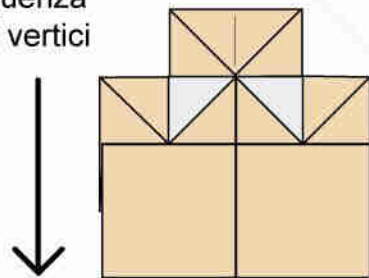

D2

Ripetete la sequenza di pieghe per 2 vertici opposti

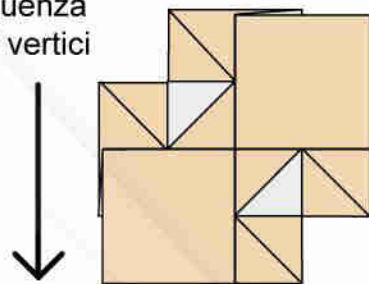

D3

Ripetete la sequenza di pieghe per 3 vertici

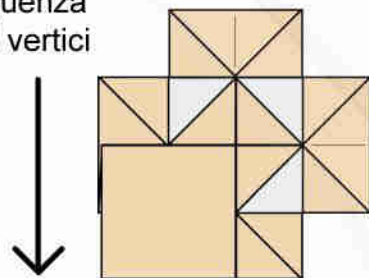

D4

Ripetete la sequenza di pieghe per 4 vertici

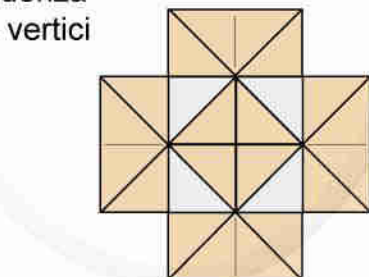

D5

MODULI ULTIMATI

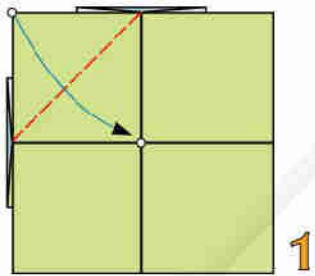

1 piega a valle e ruotate

1

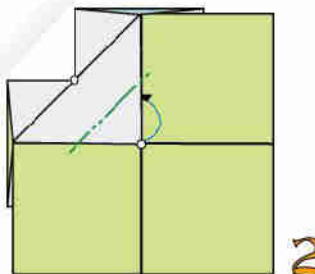

1 piega a monte e ruotate

2

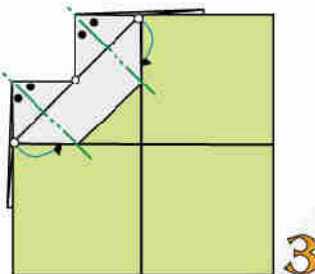

2 pieghe bisettrici a monte e ruotate

3

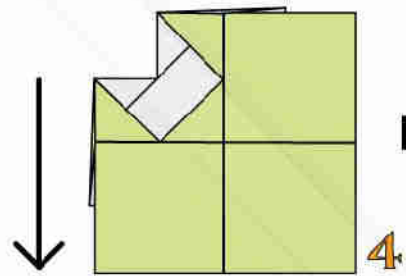

E1

4

Ripetete la sequenza di pieghe per 2 vertici adiacenti

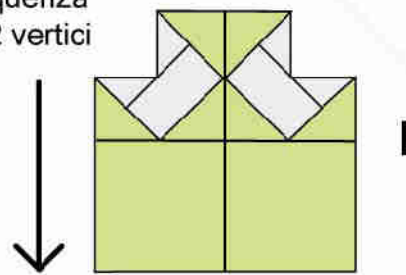

E2

Ripetete la sequenza di pieghe per 2 vertici opposti

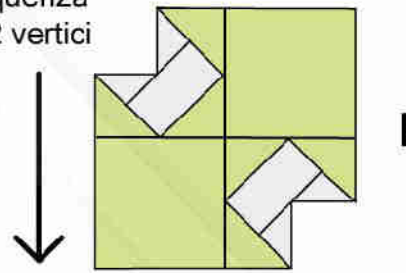

E3

Ripetete la sequenza di pieghe per 3 vertici

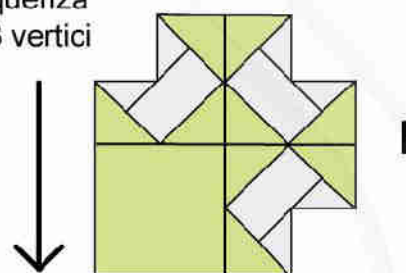

E4

Ripetete la sequenza di pieghe per 4 vertici

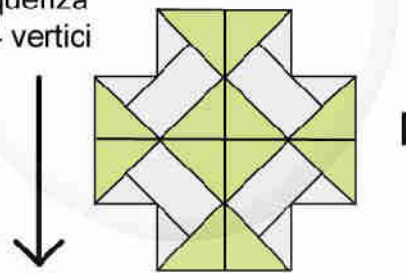

E5

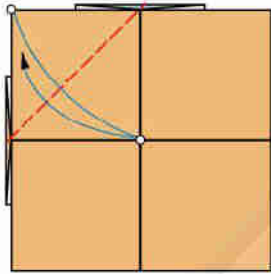

1

1 piega a valle e ruotate

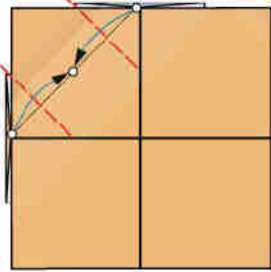

2

2 pieghe a valle e ruotate

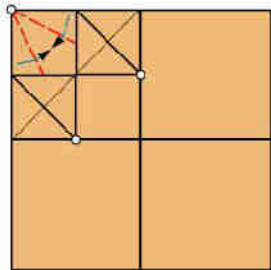

3

2 pieghe a valle (parzialmente nascoste) e ruotate

MODULI ULTIMATI

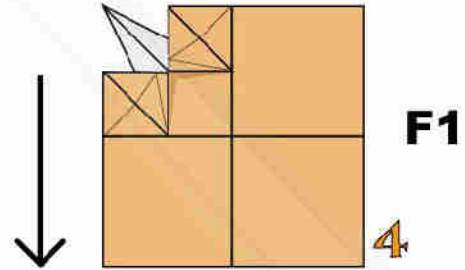

F1

4

Ripetete la sequenza di pieghe per 2 vertici adiacenti

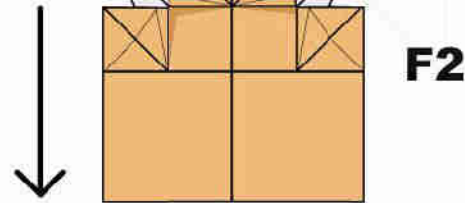

F2

Ripetete la sequenza di pieghe per 2 vertici opposti

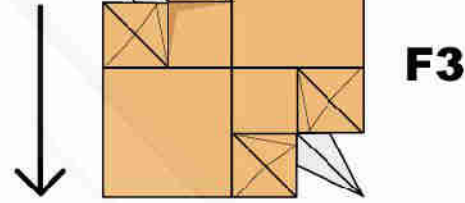

F3

Ripetete la sequenza di pieghe per 3 vertici

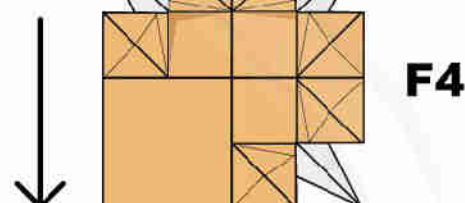

F4

Ripetete la sequenza di pieghe per 4 vertici

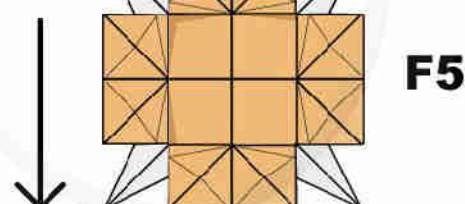

F5

MODULI ULTIMATI

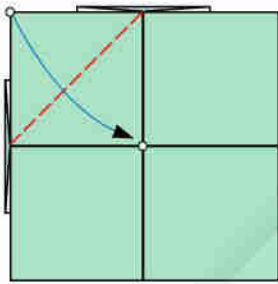

1

1 piega a valle
e ruotate

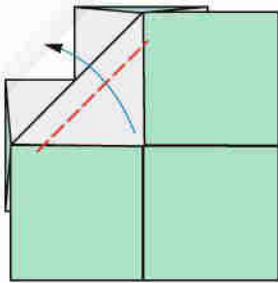

2

1 piega a valle
e ruotate

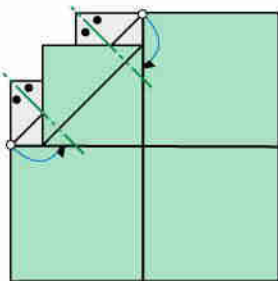

3

2 pieghe a monte
e ruotate

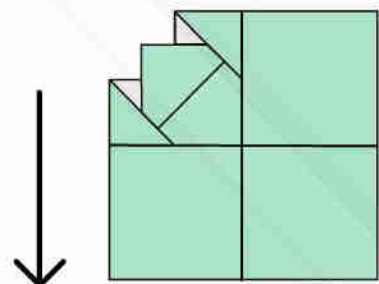

G1

4

Ripetete la sequenza
di pieghe per 2 vertici
adiacenti

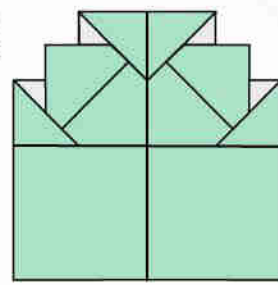

G2

Ripetete la sequenza
di pieghe per 2 vertici
opposti

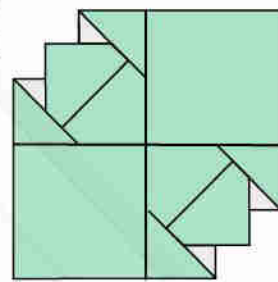

G3

Ripetete la sequenza
di pieghe per 3 vertici

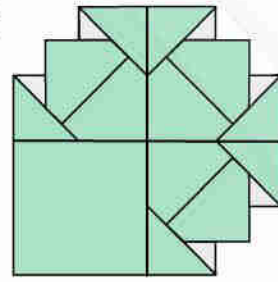

G4

Ripetete la sequenza
di pieghe per 4 vertici

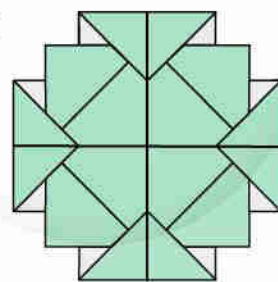

G5

MODULI ULTIMATI

1 piega a valle e ruotate

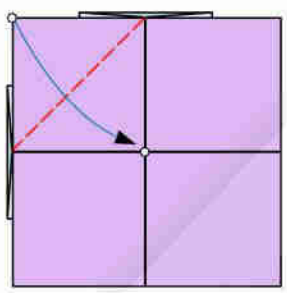

1

1 piega a valle e ruotate

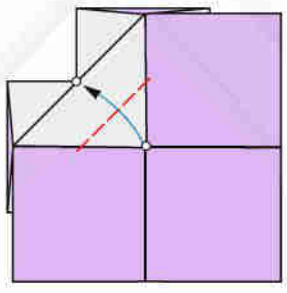

2

4 pieghe a valle, 2 a monte e ruotate

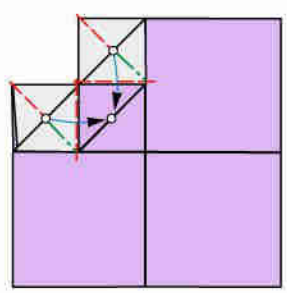

3

4 pieghe bisettrici a valle

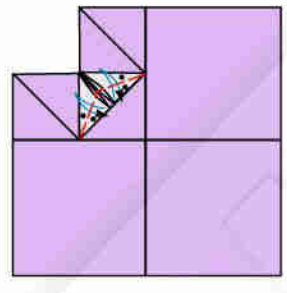

4

Ripiegando a valle ed a monte aprite i 2 triangoli

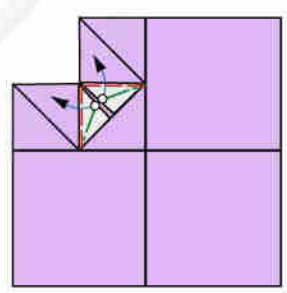

5

Ripetete la sequenza di pieghe per 2 vertici adiacenti

Ripetete la sequenza di pieghe per 2 vertici opposti

Ripetete la sequenza di pieghe per 3 vertici

Ripetete la sequenza di pieghe per 4 vertici

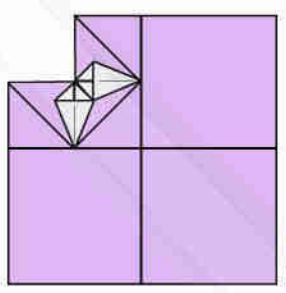

6

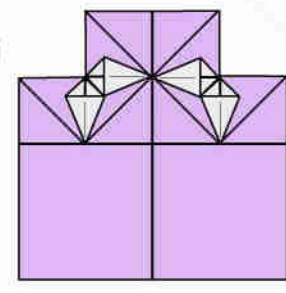

H2

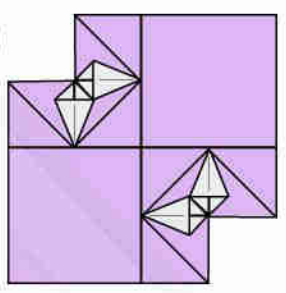

H3

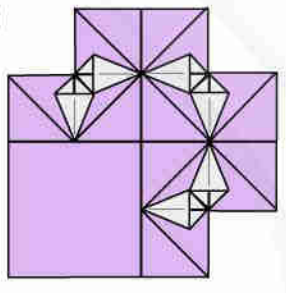

H4

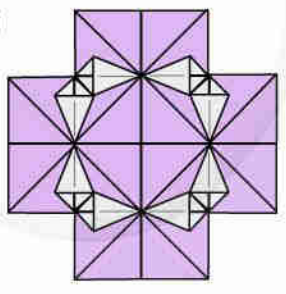

H5

MODULI ULTIMATI

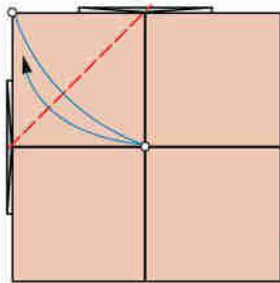

1 piega a valle

1

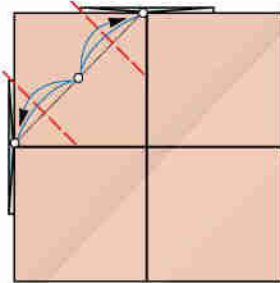

2 pieghe a valle

2

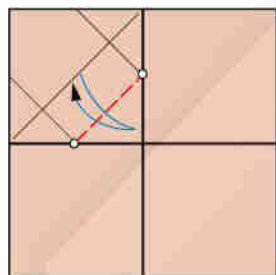

1 piega a valle

3

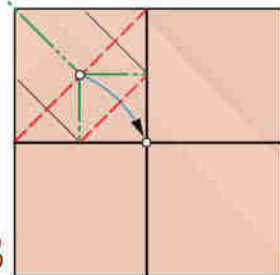

3 pieghe a monte e ruotate 3D ripiegando a valle

4

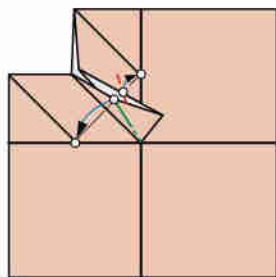

Mediante 2 pieghe a monte appiattite il triangolo verticale

5

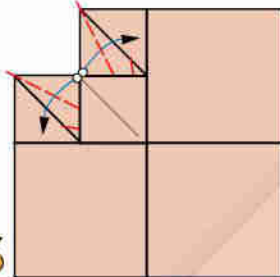

4 pieghe a valle solo sulla sup. in vista ed aprite

6

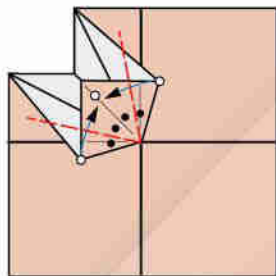

2 pieghe bisettrici a valle e ruotate

7

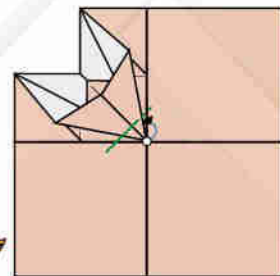

1 piega a monte e ruotate

8

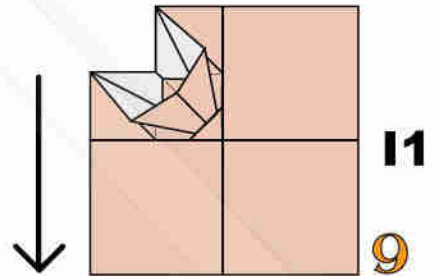

I1

9

Ripetete la sequenza di pieghe per 2 vertici adiacenti

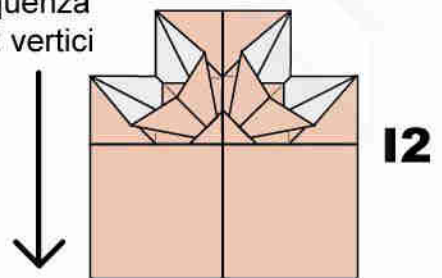

I2

Ripetete la sequenza di pieghe per 2 vertici opposti

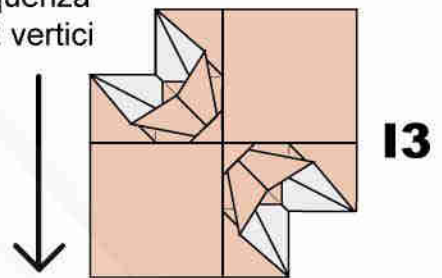

I3

Ripetete la sequenza di pieghe per 3 vertici

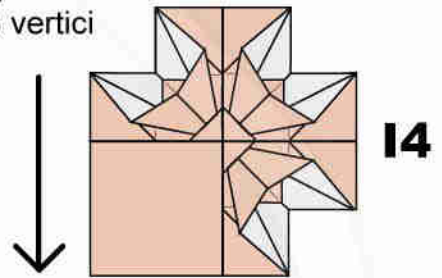

I4

Ripetete la sequenza di pieghe per 4 vertici

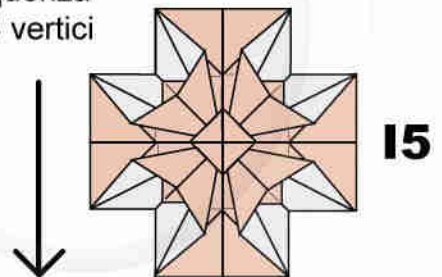

I5

1 piega
a valle

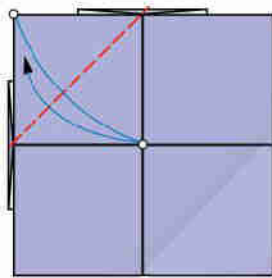

1

1 piega
a valle

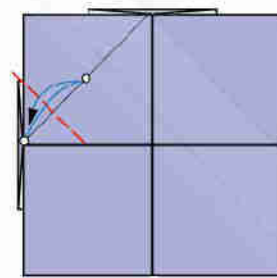

2

1 piega
rovescia
interna

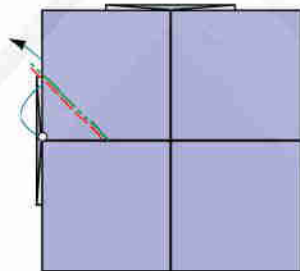

3

1 piega
a valle e
ruotate

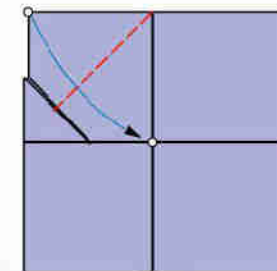

4

1 piega
rovescia
interna

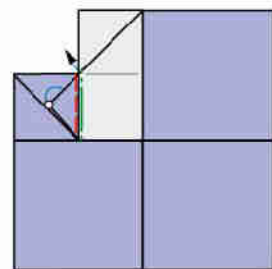

5

1 piega a
monte e
ruotate
intascando

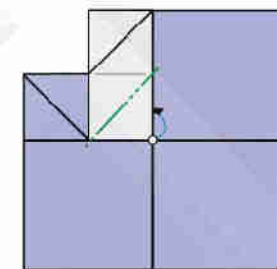

6

1 piega a
monte e
ruotate

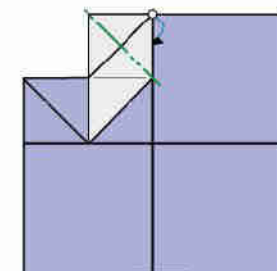

7

MODULI ULTIMATI

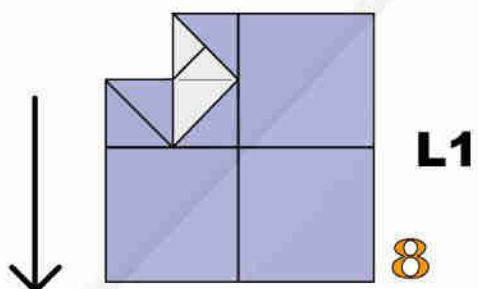

Ripetete la sequenza di pieghe per 2 vertici adiacenti

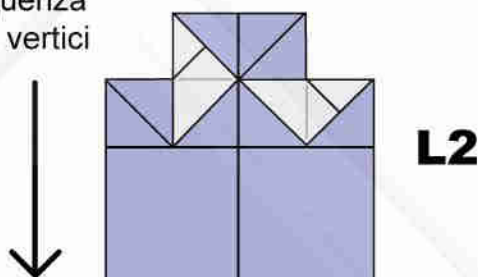

Ripetete la sequenza di pieghe per 2 vertici opposti

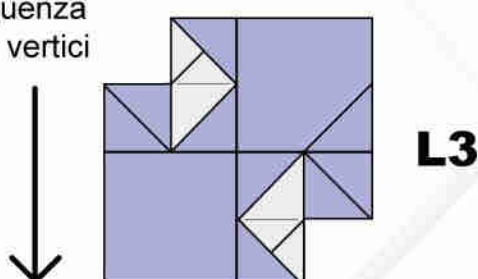

Ripetete la sequenza di pieghe per 3 vertici

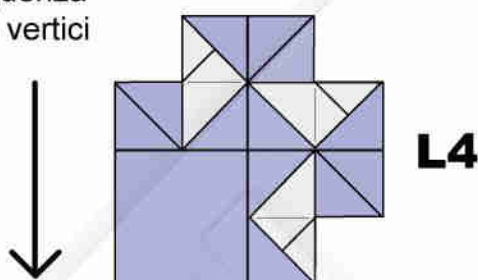

Ripetete la sequenza di pieghe per 4 vertici

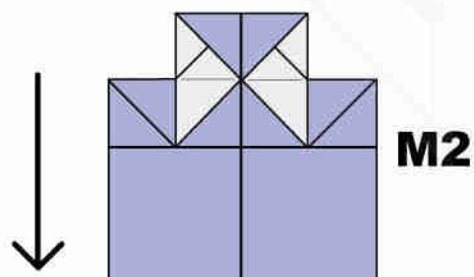
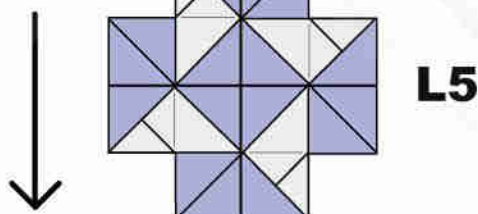

Ripetete simmetricamente la sequenza di pieghe per 2 vertici adiacenti

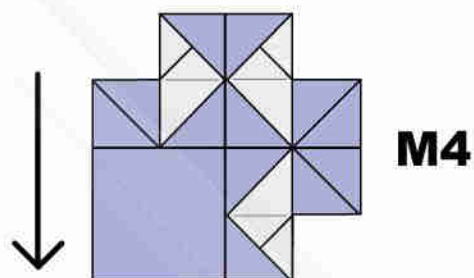

Ripetete simmetricamente la sequenza di pieghe per 3 vertici

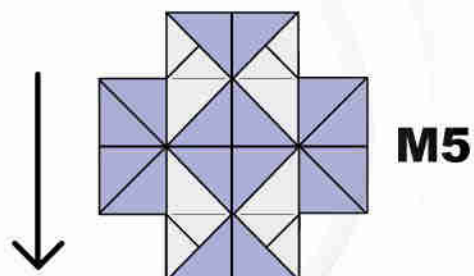

Ripetete simmetricamente la sequenza di pieghe per 4 vertici

MODULI 3D

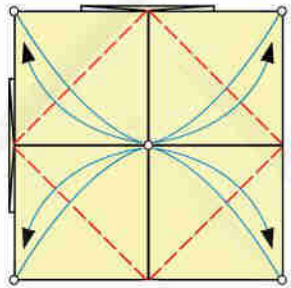

1

4 pieghe a valle

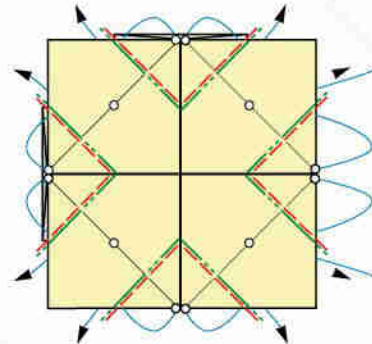

2

4 pieghe rovesce interne

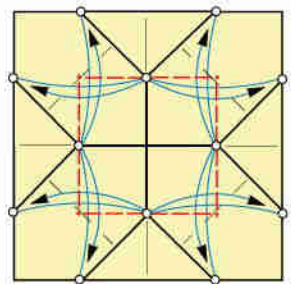

3

4 pieghe a valle

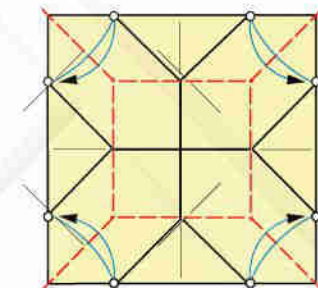

4

4 pieghe diagonali a valle e, ripiegando, modellate 3D

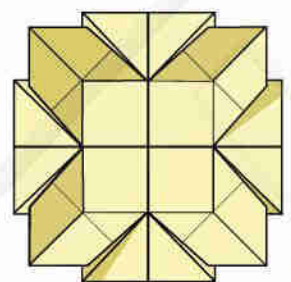

5

Modulo **N** ultimato

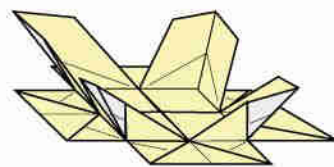

Assonometria

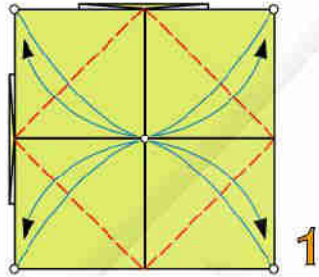

4 pieghe a valle

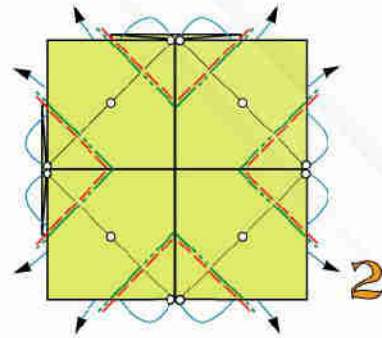

4 pieghe rovesce interne

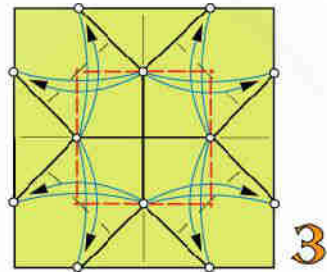

4 pieghe a valle

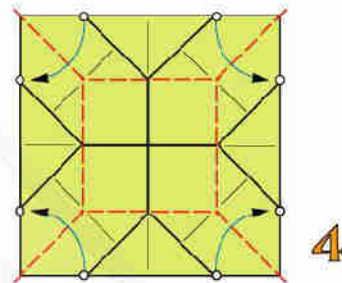

4 pieghe diagonali a valle e, ripiegando, modellate 3D congiungendo i punti indicati

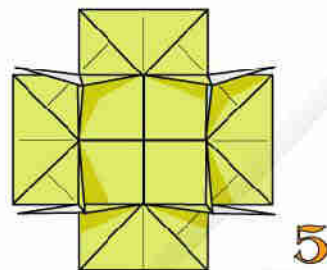

5

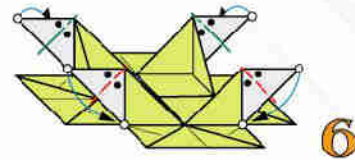

Assonometria: 4 pieghe bisettrici a valle, 2 per lato

6

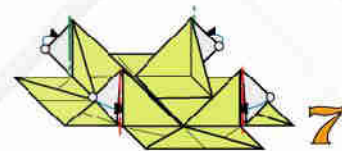

4 pieghe bisettrici a valle, 2 per lato e intascate

7

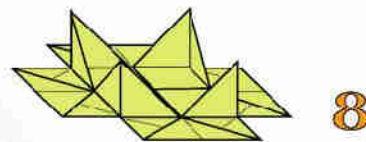

Modulo **O** ultimato

8

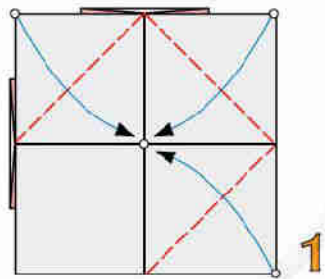

Adoperate carta leggera.
3 pieghe a valle e ruotate

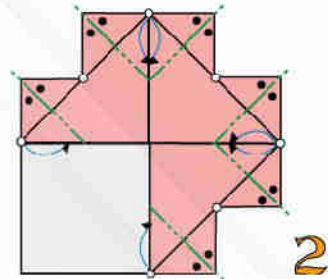

6 pieghe bisettrici a monte e ruotate

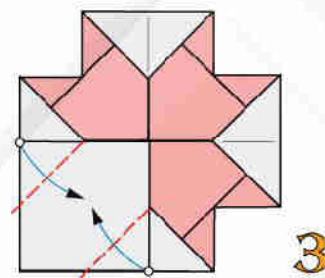

2 pieghe a valle e ruotate

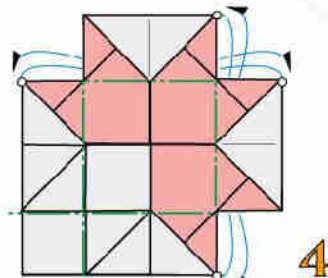

4 pieghe a monte

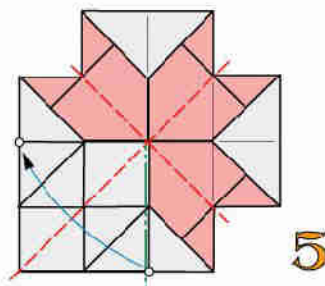

2 pieghe a valle, 1 a monte e ruotate 3D

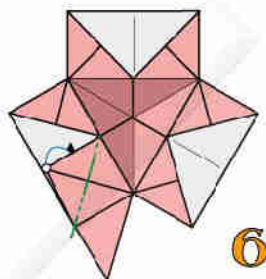

1 piega a monte e ruotate

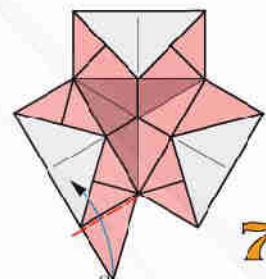

1 piega a valle e ruotate

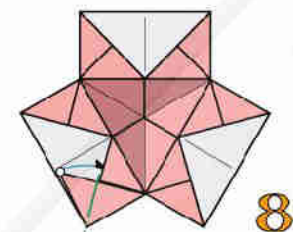

1 piega a monte e intascate

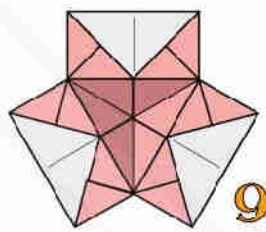

Ribaltate

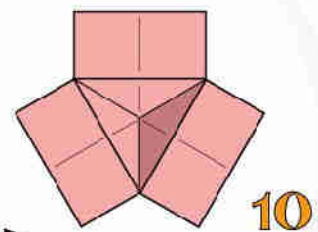

Modulo **P** ultimato

ESEMPIO DI TASSELLAZIONE ESEGUITA CON MODULI P

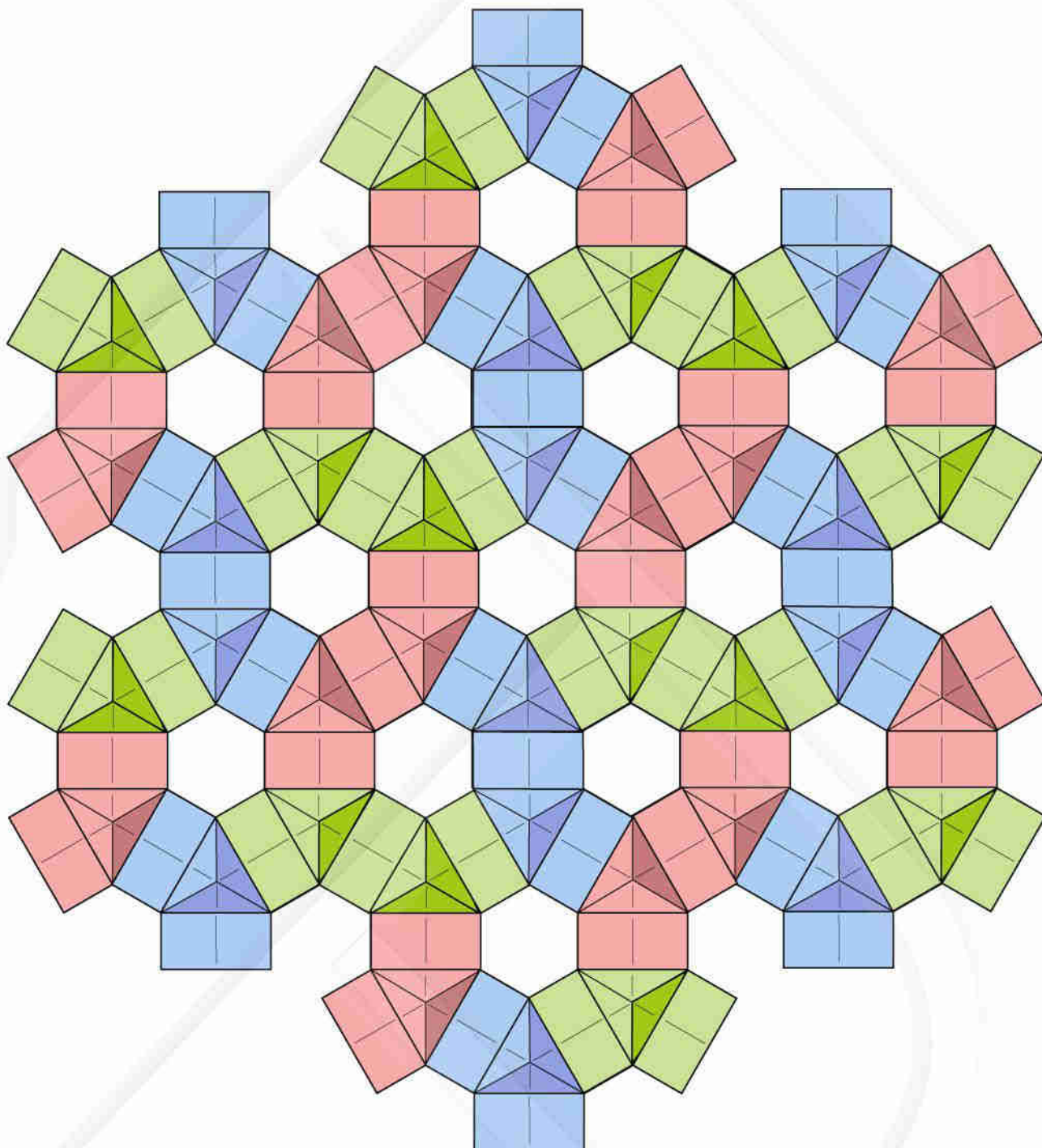

TIPOLOGIE DI UNIONE DEI MODULI

Si presentano solamente alcuni tipi di aggregazioni, in quanto le combinazioni possono essere molte. Se poi si variano i moduli, le combinazioni diventano innumerevoli.

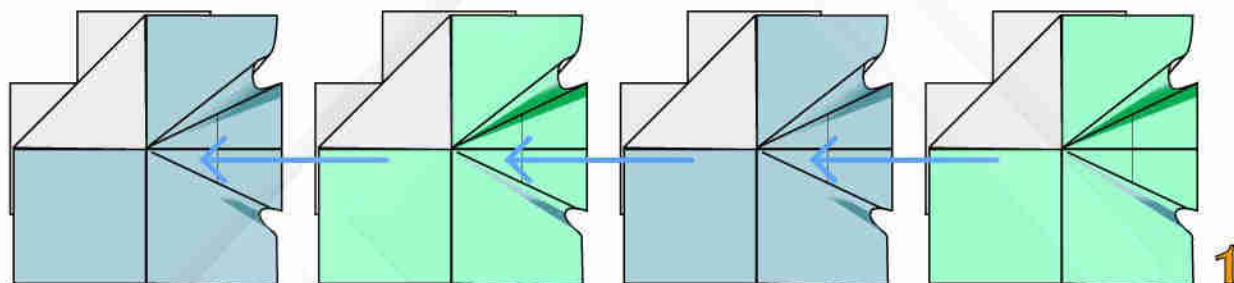

Riga con unione in successione- **X**

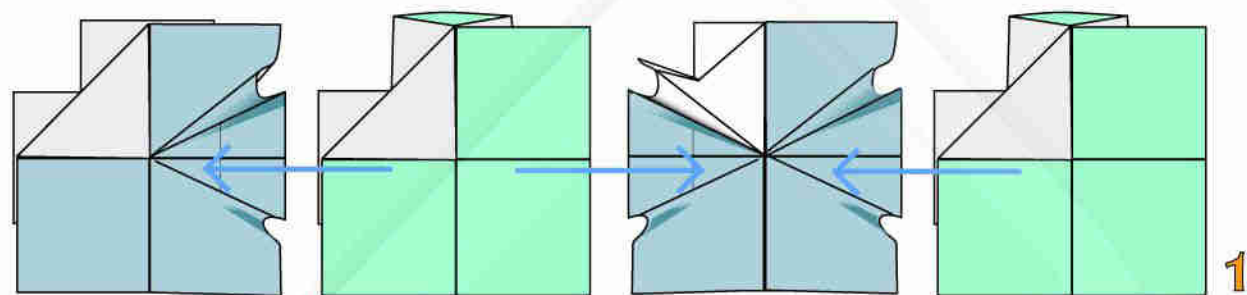
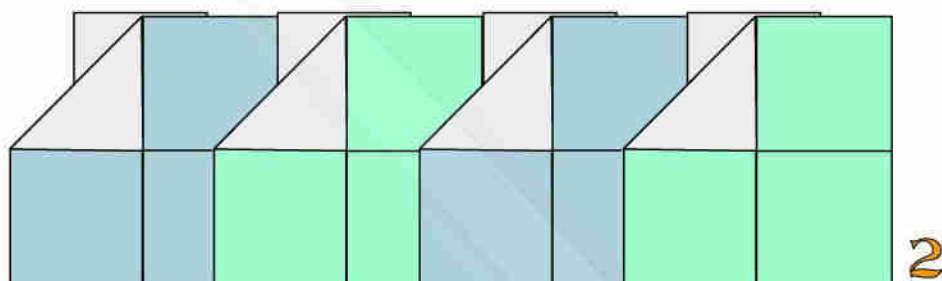

Riga con sovrapposizione alternata- **Y**

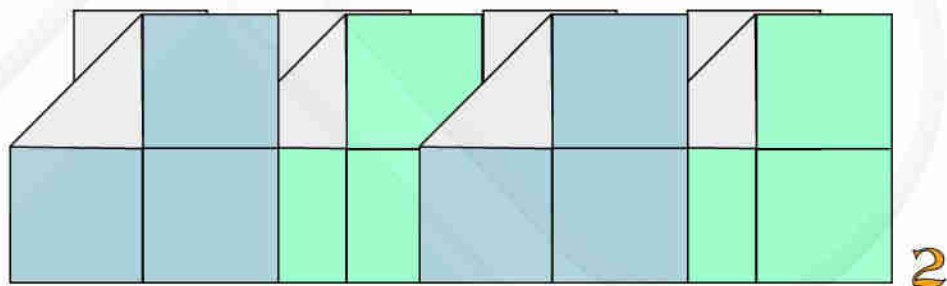

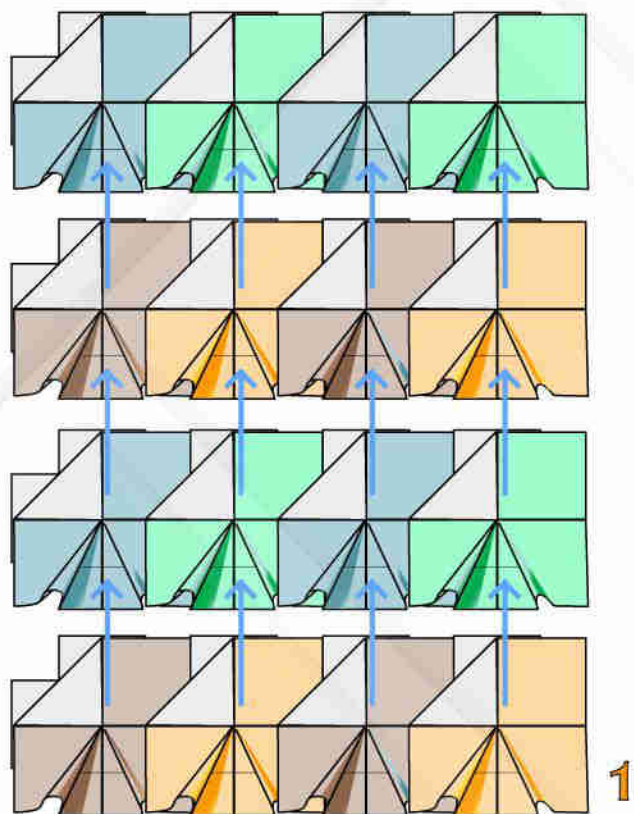

1

Righe **X** unite verticalmente in successione

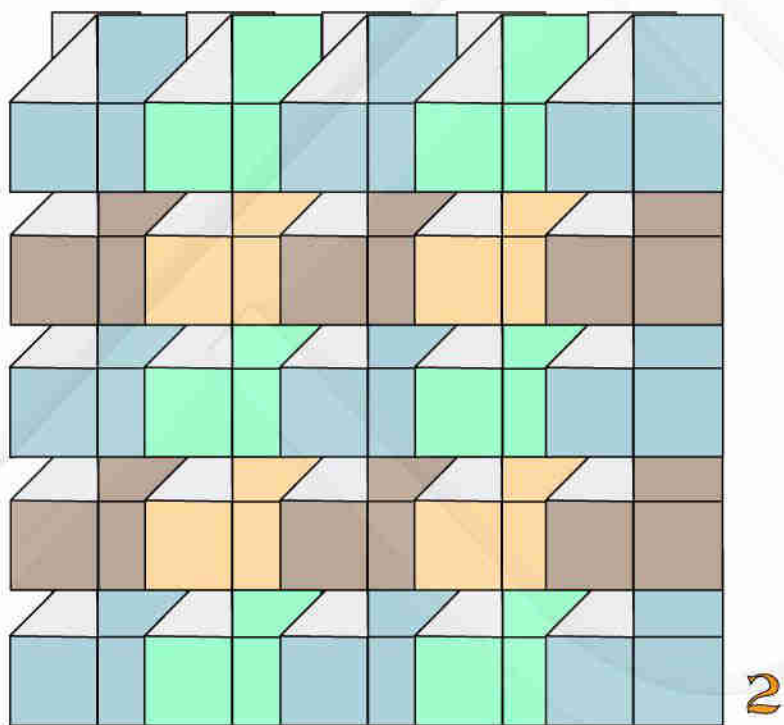

2

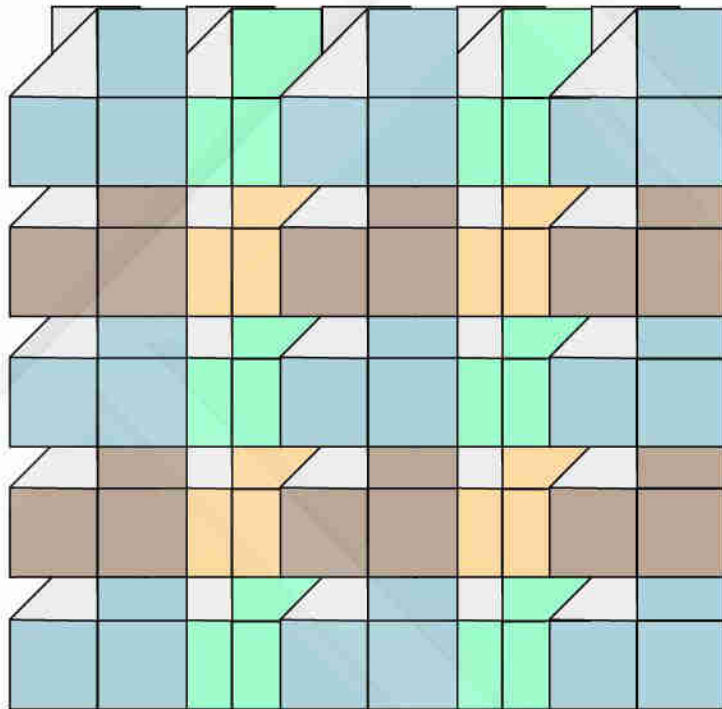

Righe **Y** unite verticalmente in successione

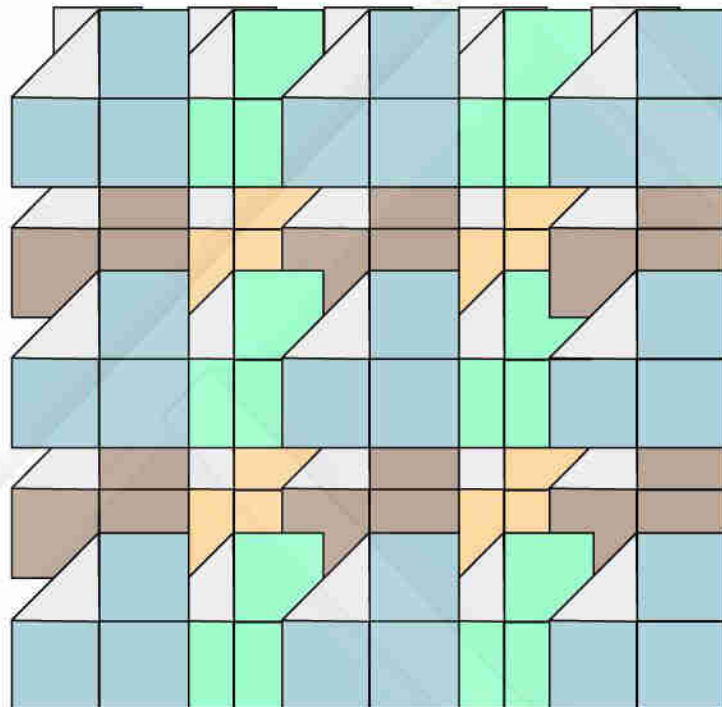

Righe **Y** unite verticalmente con sovrapposizione alternata

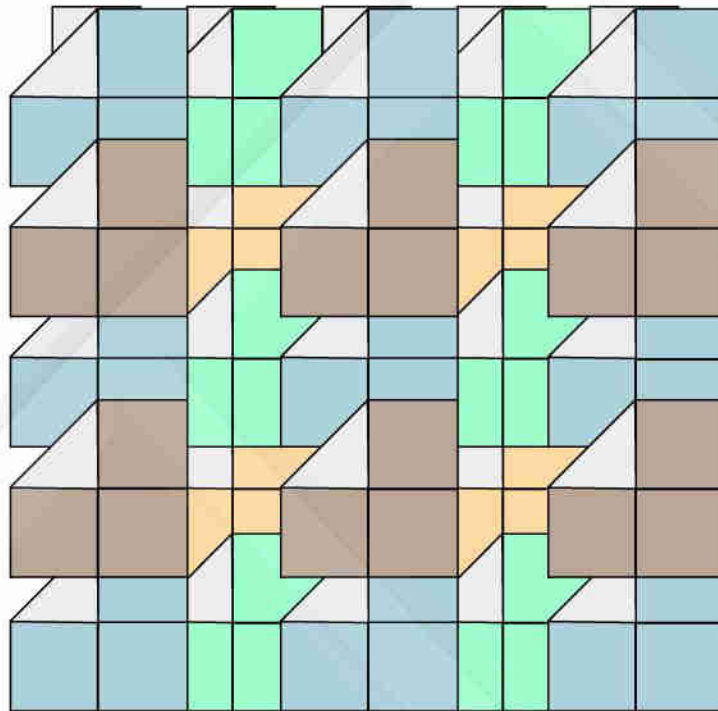

Righe **Y** unite verticalmente con sovrapposizione alternata

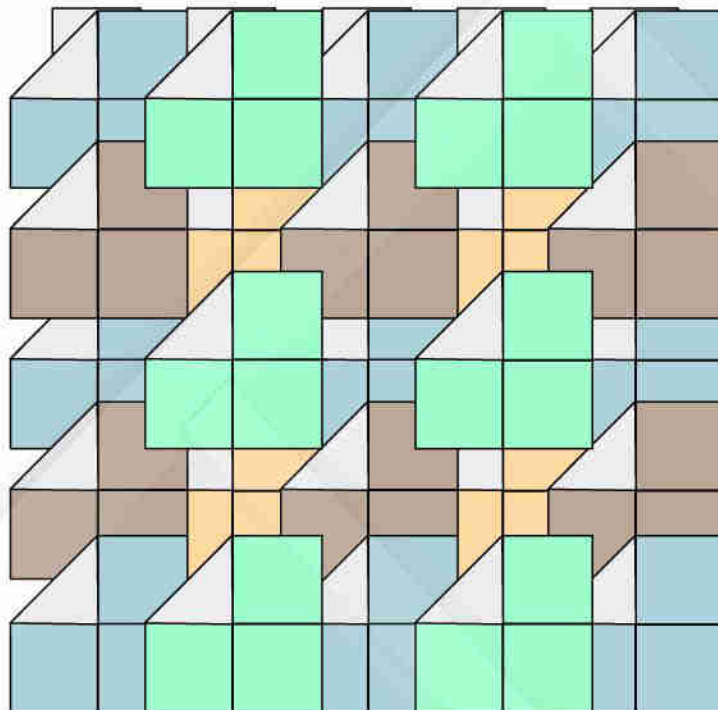

Righe **Y** unite verticalmente con sovrapposizione alternata scalata

ESEMPI DI TASSELLAZIONI CON MODULI A, B_n e C_n

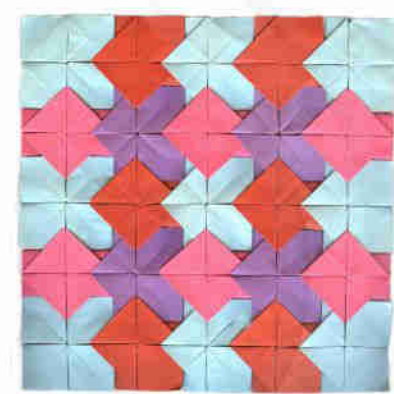
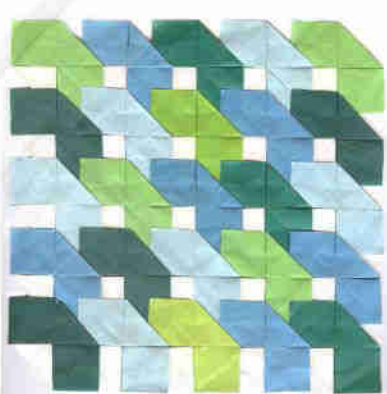
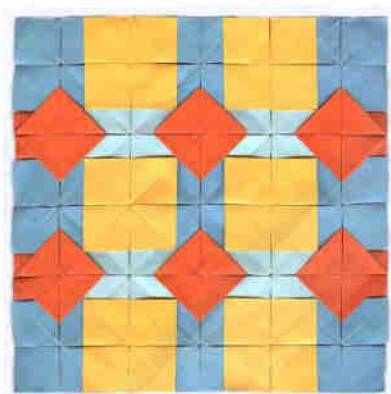

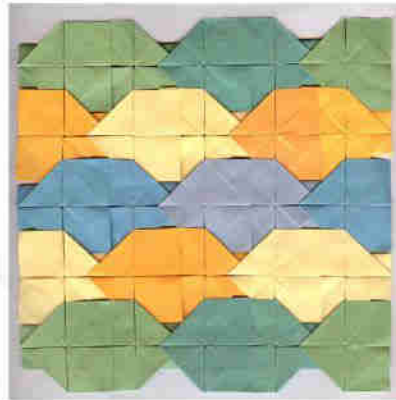

TASSELLAZIONE A GRATICCIO

Il modulo "graticcio" serve per realizzare trame verticali e, data la sua grande robustezza, è adatto per la costruzione di graticci verticali a cui appendere oggettini vari, come animaletti, decorazioni o regali per le feste. Si realizza unendo moduli R con moduli graticcio.

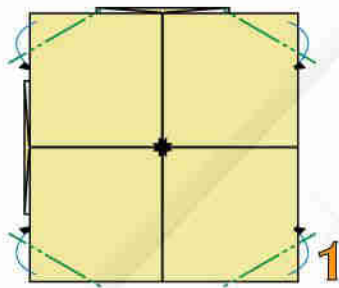

Partite dal modulo base A.
4 pieghe a monte e ruotate

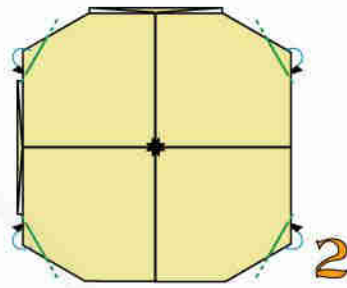

4 pieghe a monte e ruotate

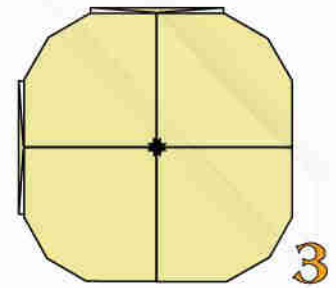

Modulo **R** ultimato

MODULO GRATICCIO

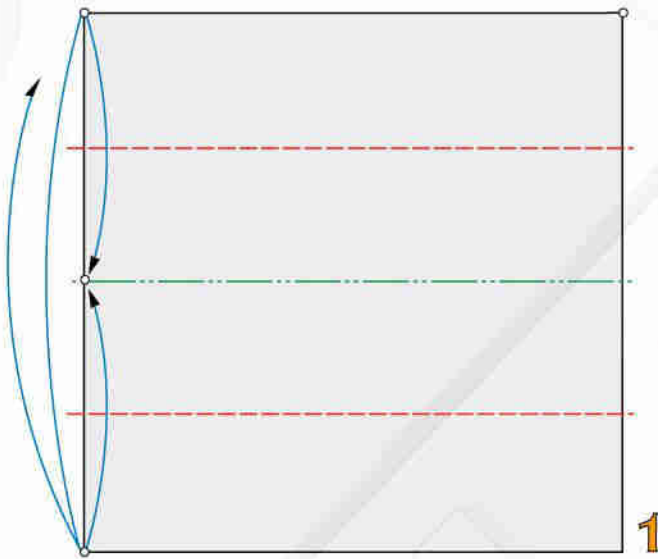

1 piega a monte, 2 a valle e ruotate



2 pieghe a monte sottostanti e ruotate



4 pieghe rovesce interne



2 pieghe a monte sottostanti,
ruotate e ribaltate

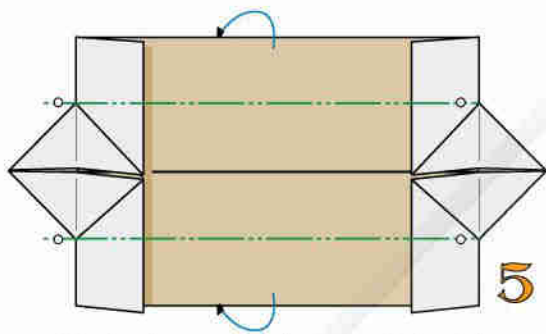

2 pieghe a monte e ruotate intascando

5



4 pieghe a monte e ruotate intascando

6

Modulo
GRATICCIO
ultimato

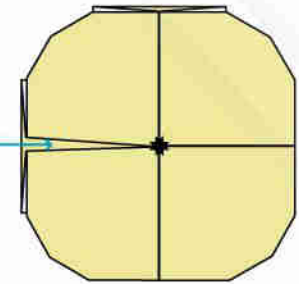

1

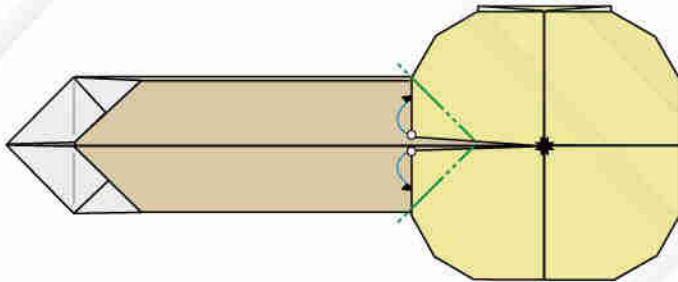

Bloccate l'unione agganciando a monte i 2 vertici indicati

2

UNIONE DI UN MODULO
GRATICCIO CON UN
MODULO **R**

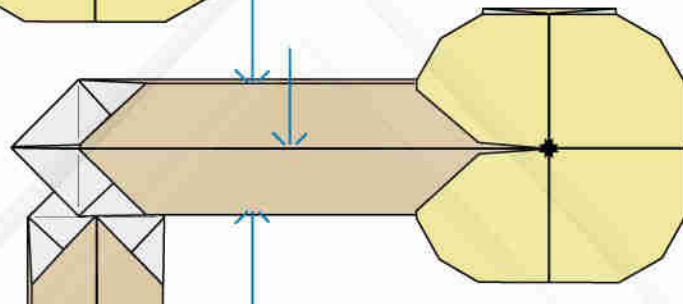

3

Unione completata.
Ora potete collegare altri 3 moduli.
Potete notare che il modulo
Graticcio dispone di 3 tasche
utili per agganciare altri oggetti

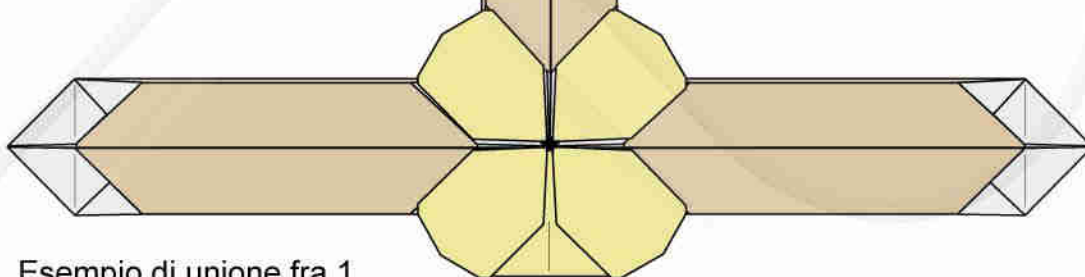

Esempio di unione fra 1
modulo R e 3 moduli Graticcio

MODULO FOGLIA PER GRATICCIO

Si parte da mezzo foglio quadrato e si ottiene una foglia che si può inserire nella tasca centrale del modulo graticcio. In questo si possono posizionare fino a 3 foglie.

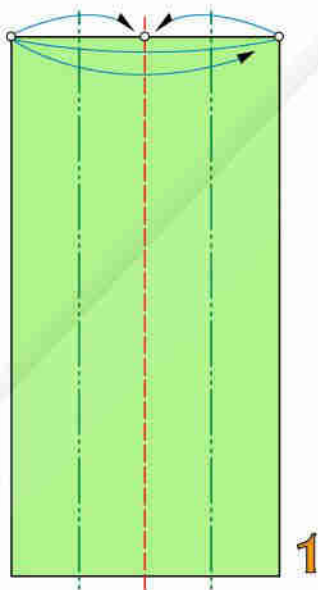

1 piega a valle,
2 a monte e ruotate

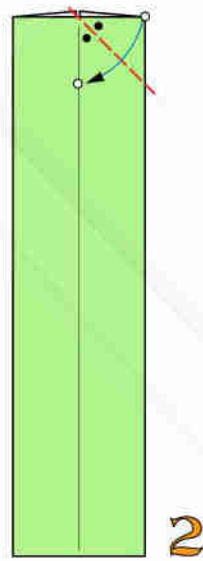

1 piega bisettrice
a valle e ruotate

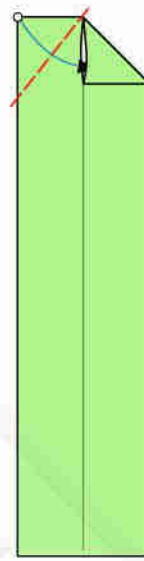

1 piega a valle e
ruotate intascando

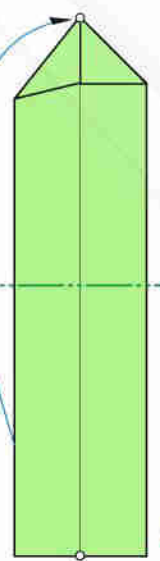

1 piega a monte
e ruotate

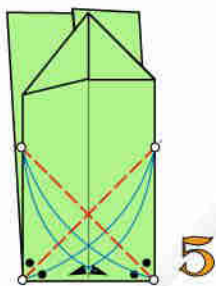

2 pieghe bisettrici
a valle solo sulla
sup. in vista e
ruotate

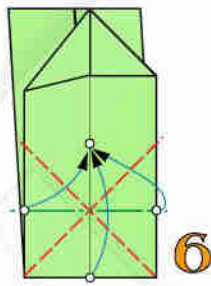

1 piega a monte e
ruotate ripiegando
a valle

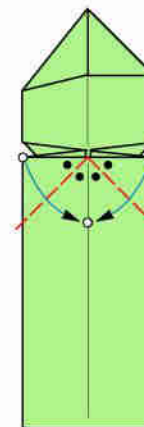

2 pieghe bisettrici
a valle e ruotate

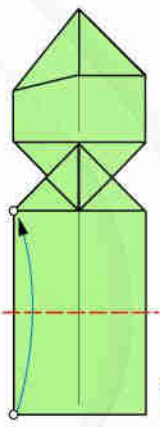

1 piega a valle
e ruotate

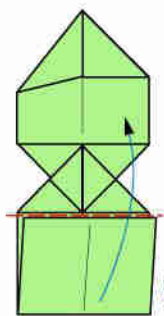

9

1 piega a valle,
ruotate e ribaltate

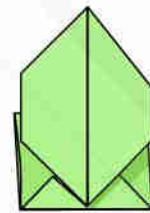

10

Modulo foglia ultimato

INSERIMENTO DEL MODULO FOGLIA NEL MODULO GRATICCIO

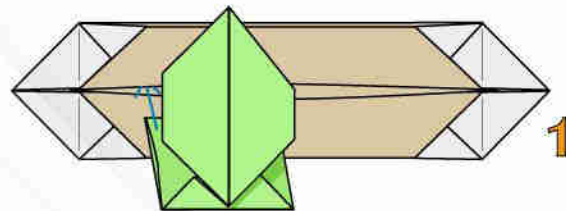

1

Intascate il bordo indicato nella tasca centrale del graticcio

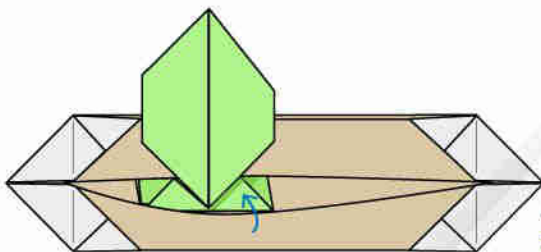

2

Intascate anche il bordo inferiore della foglia

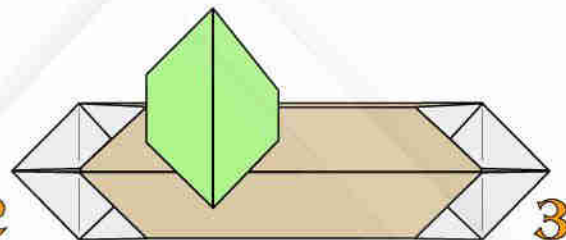

3

Bloccaggio ultimato

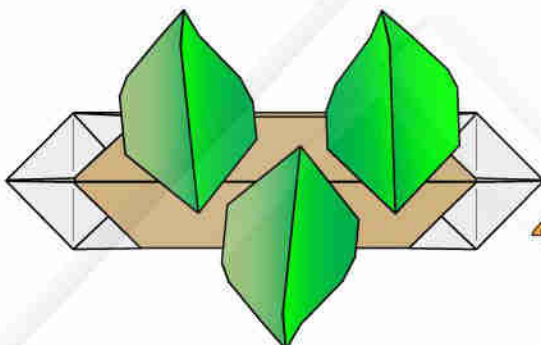

4

Si possono inserire fino a 3 foglie

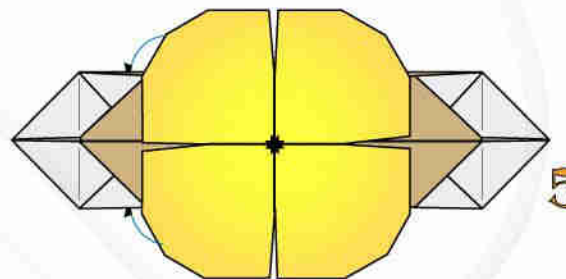

5

Si può inserire un fiore derivato dal modulo 1 intascando 2 vertici posteriori nelle tasche superiore ed inferiore del graticcio

ESEMPIO DI GRATICCIO

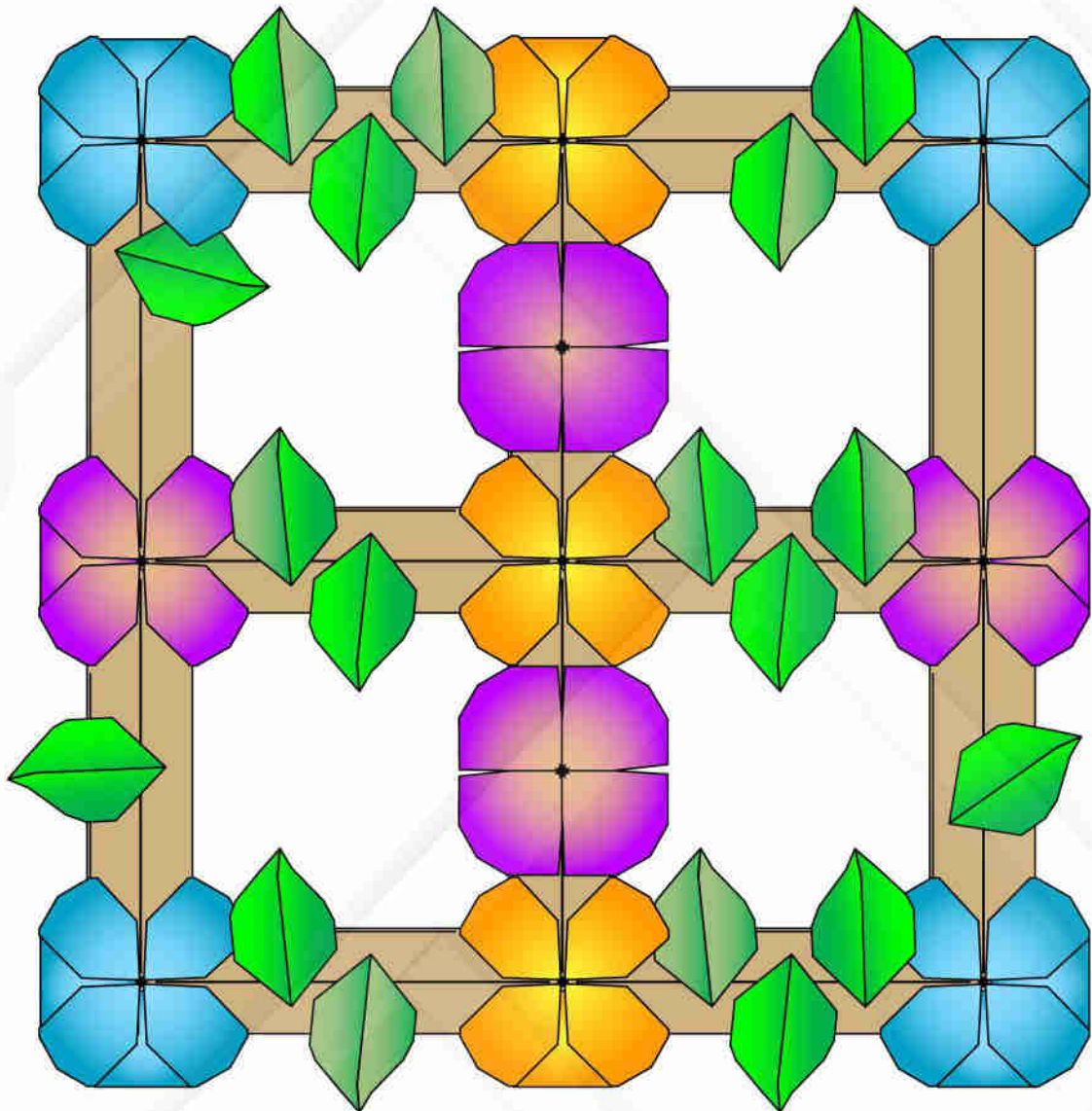

TASSELLAZIONI MODULARI COMPATIBILI

Queste tassellazioni costituiscono la naturale evoluzione di quelle presentate in un mio vecchio libro del 1989.

I moduli, abbastanza semplici, sono compatibili fra loro poichè le unioni avvengono nello stesso modo.

Sostituendo del tessuto alla carta, si può pensare ad un loro utilizzo nel campo della moda.



MODULO "A"

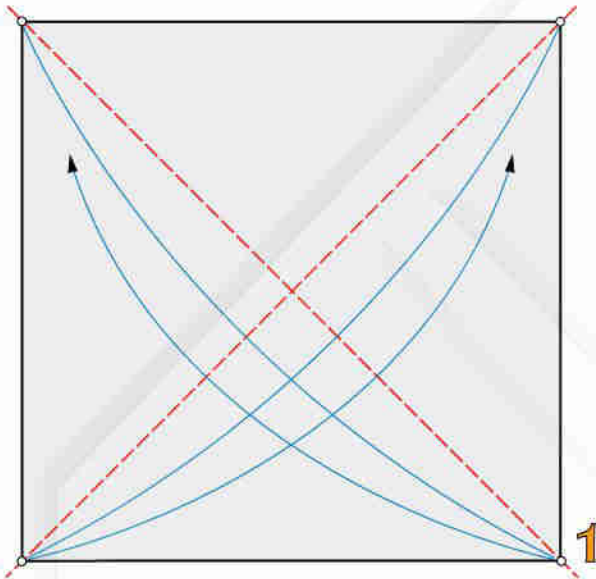

2 pieghe diagonali a valle

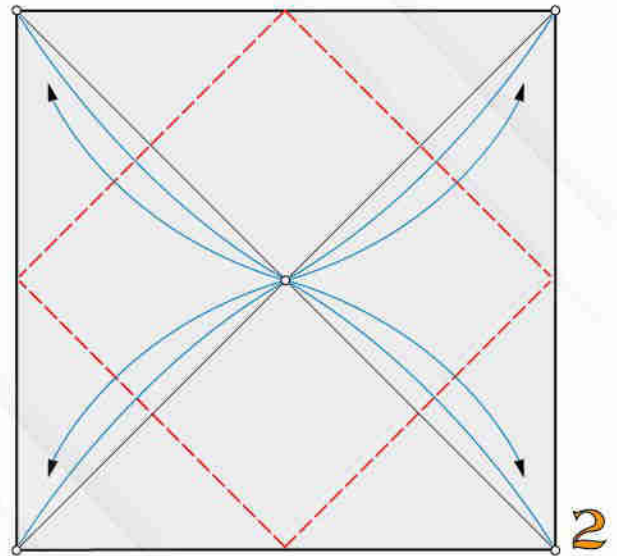

4 pieghe a valle

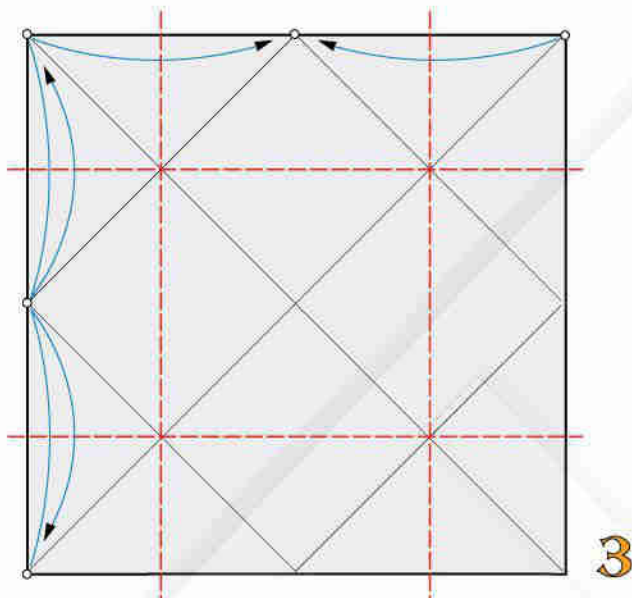

4 pieghe a valle e ruotate i bordi laterali

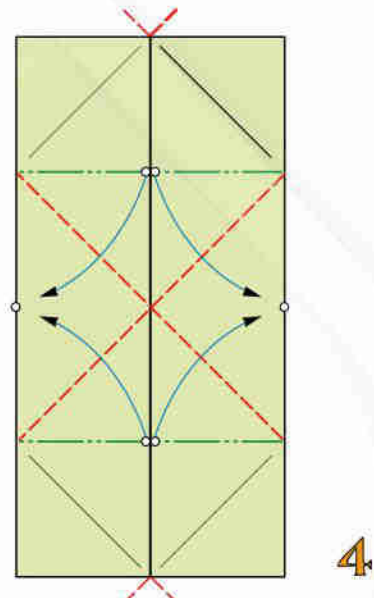

Ruotate ripiegando 4 volte a valle ed a monte sulla sup. in vista e 4 volte a valle su quella sottostante

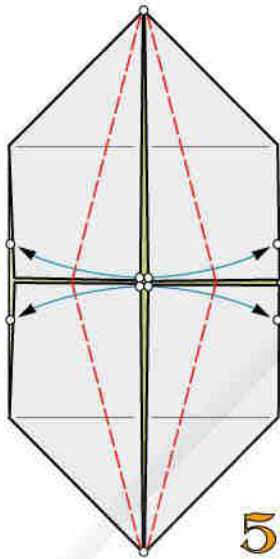

5

4 pieghe a valle e ruotate

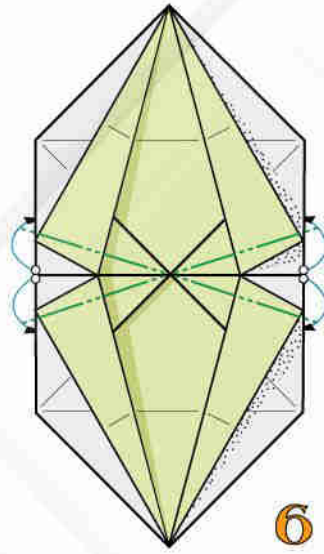

6

4 pieghe a monte e ruotate

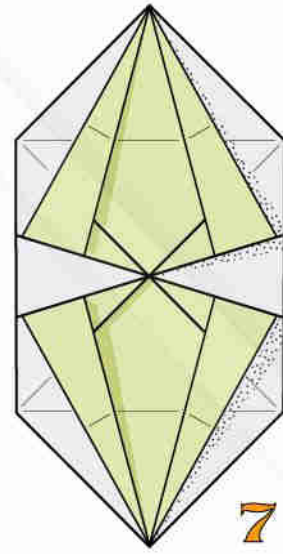

7

Modulo "A" ultimato

UNIONE DI 2 MODULI

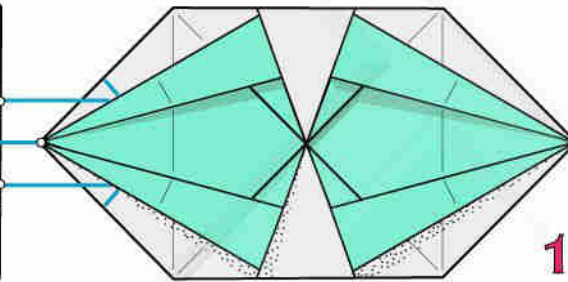
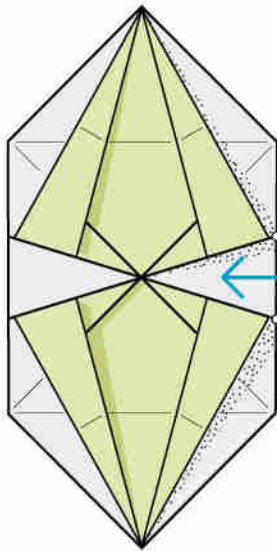

1

Intascate i 2 vertici del modulo di sinistra sotto i bordi del modulo di destra e quello centrale del modulo di destra entro il modulo di sinistra

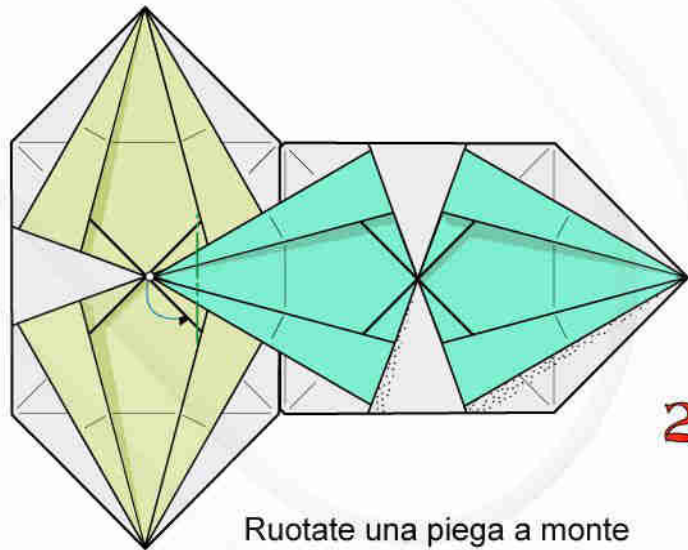

2

Ruotate una piega a monte bloccando l' unione

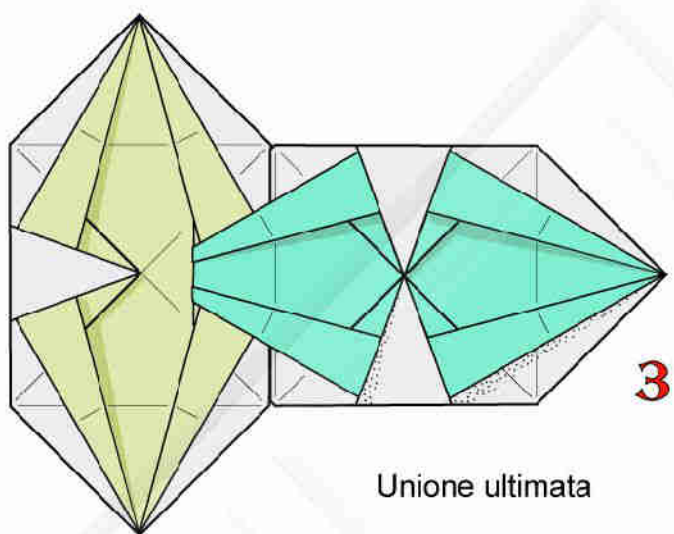

Unione ultimata

ESEMPIO DI TASSELLAZIONE ESEGUITA CON 16 MODULI "A"

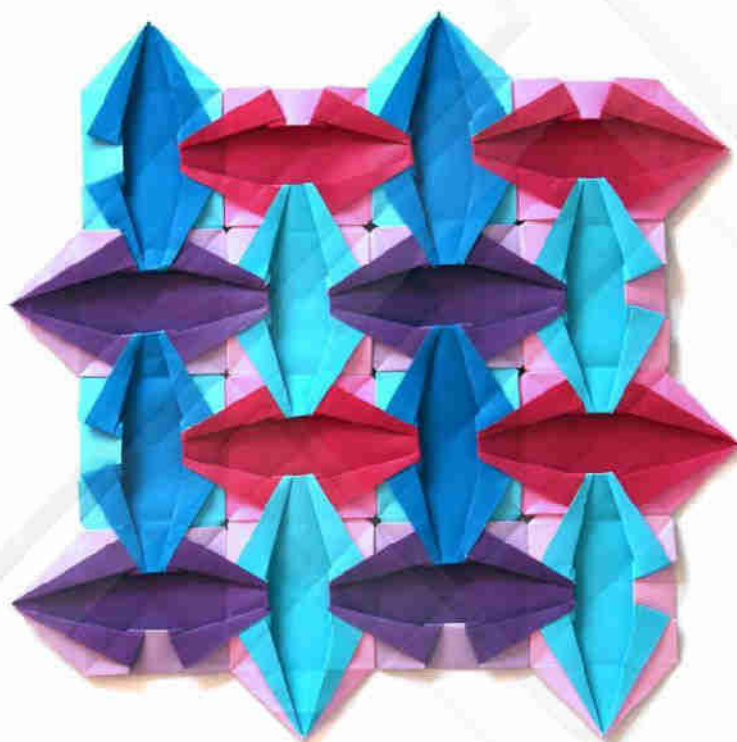

MODULO "B"

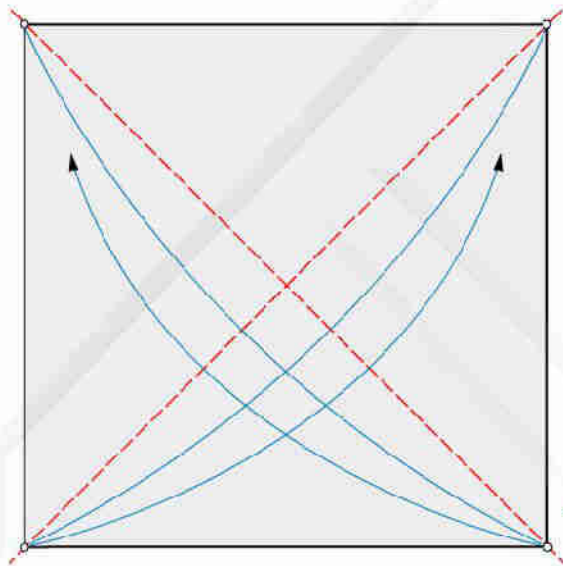

2 pieghe diagonali a valle

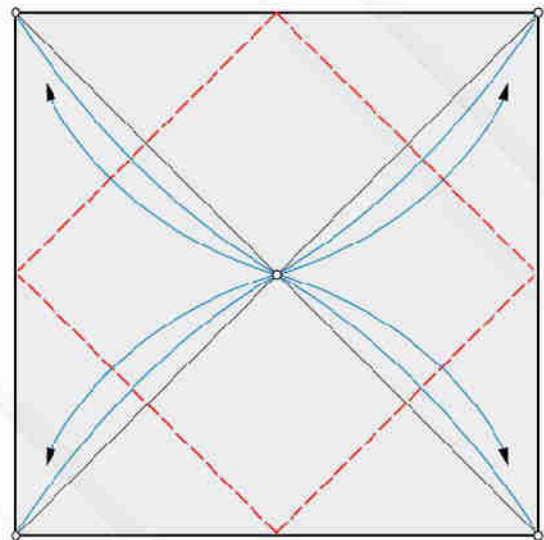

4 pieghe a valle

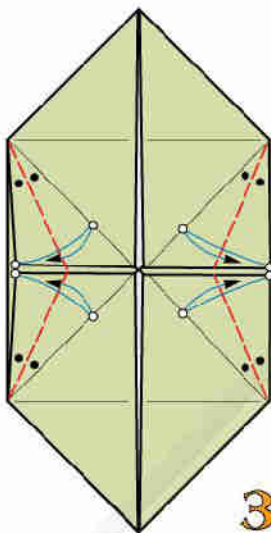

4 pieghe bisettrici a valle

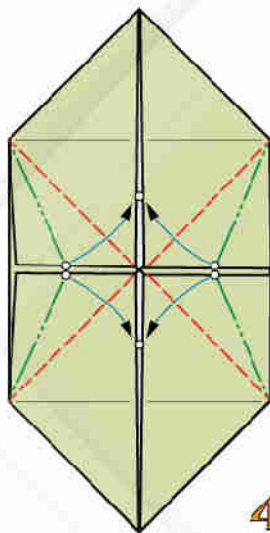

Ruotate ripiegando 4 volte a valle e 4 volte a monte

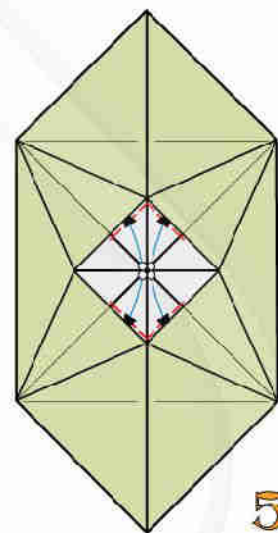

Mediante 4 pieghe a valle, intascate i 2 vertici superiori ed i 2 vertici inferiori

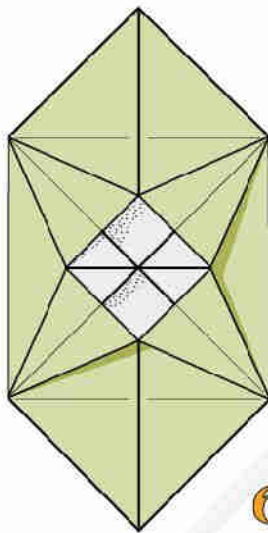

6

Modulo "B" ultimato

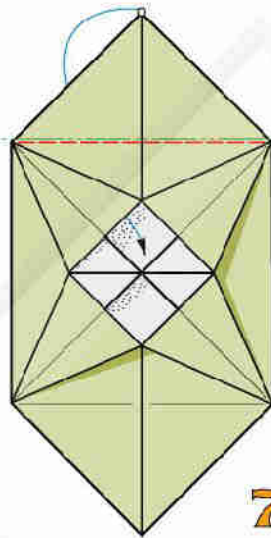

7

Modulo "B" di bordo:
eseguite una piega
rovescia interna

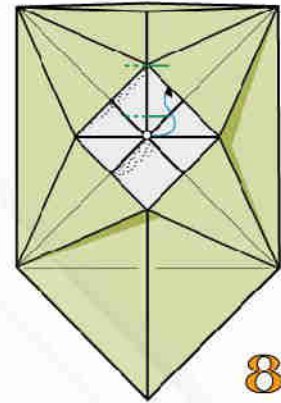

8

Mediante 2 pieghe a monte
(quella interna non visibile)
ruotate all'interno il vertice
superiore

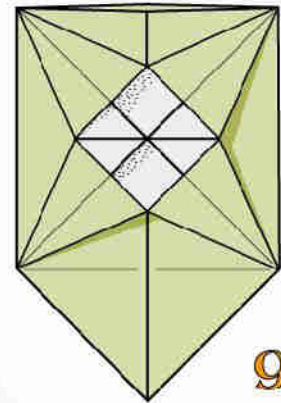

9

Modulo "B" di bordo
ultimato

UNIONE DI 2 MODULI

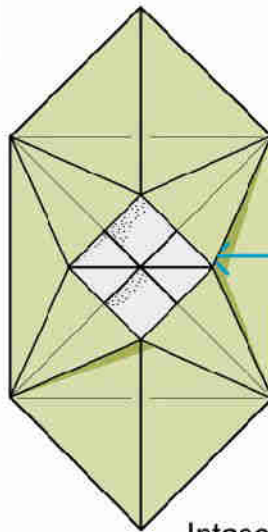

Intascate un modulo
nell'altro

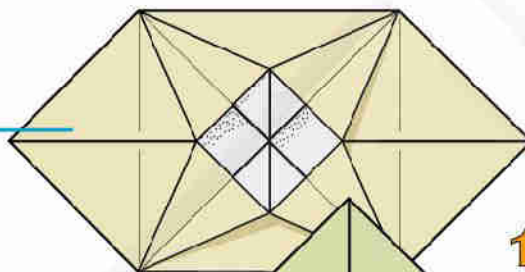

1

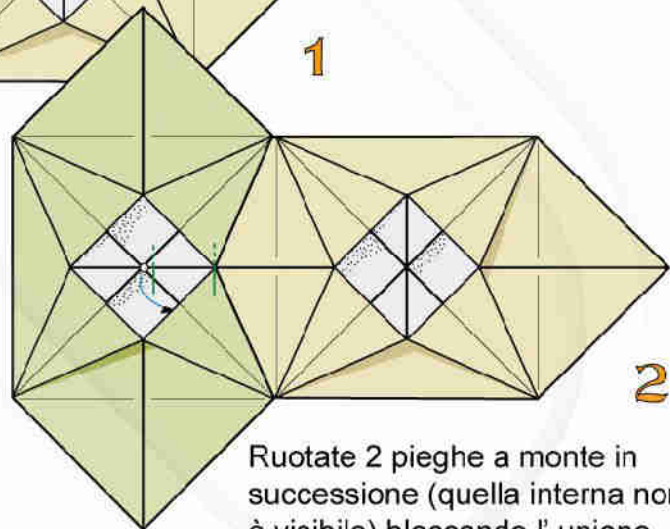

2

Ruotate 2 pieghe a monte in
successione (quella interna non
è visibile) bloccando l' unione

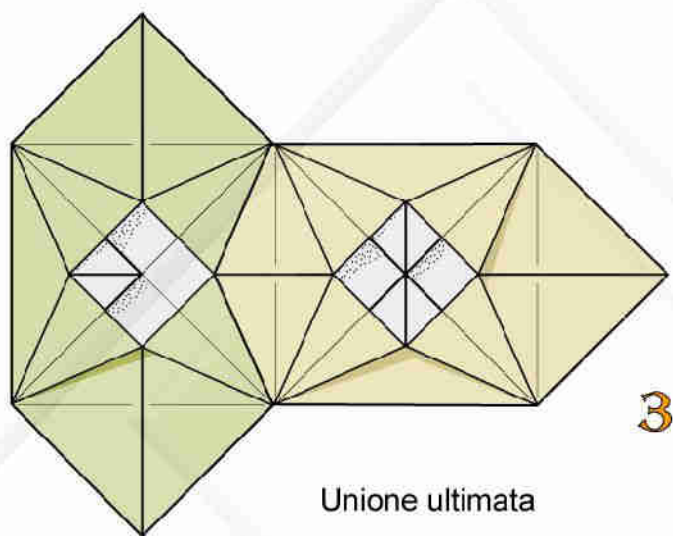

ESEMPIO DI TASSELLAZIONE ESEGUITA CON 16 MODULI "B"



MODULO "C"

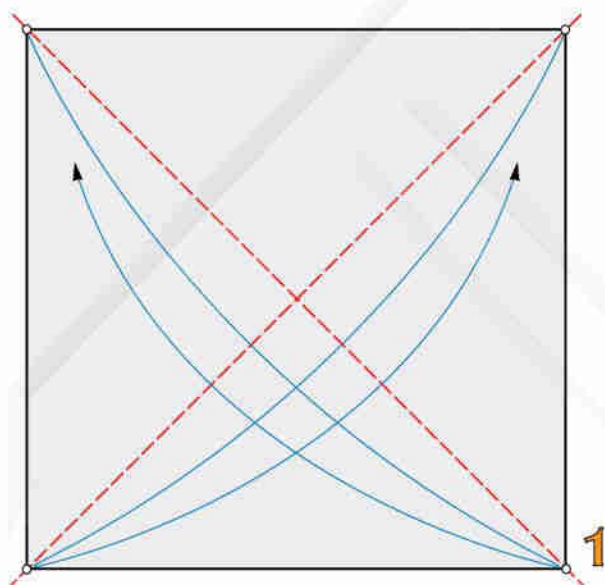

2 pieghe diagonali a valle

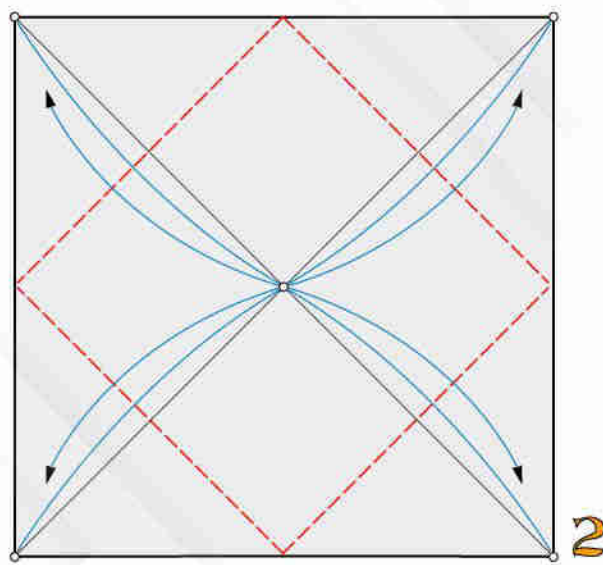

4 pieghe a valle

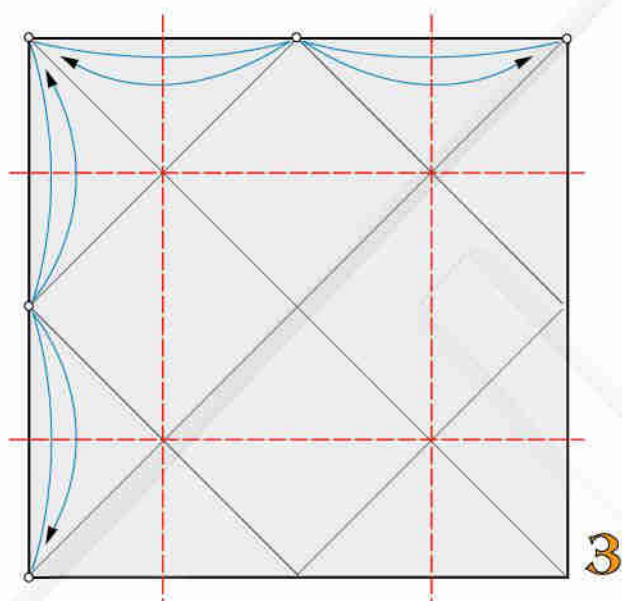

4 pieghe a valle

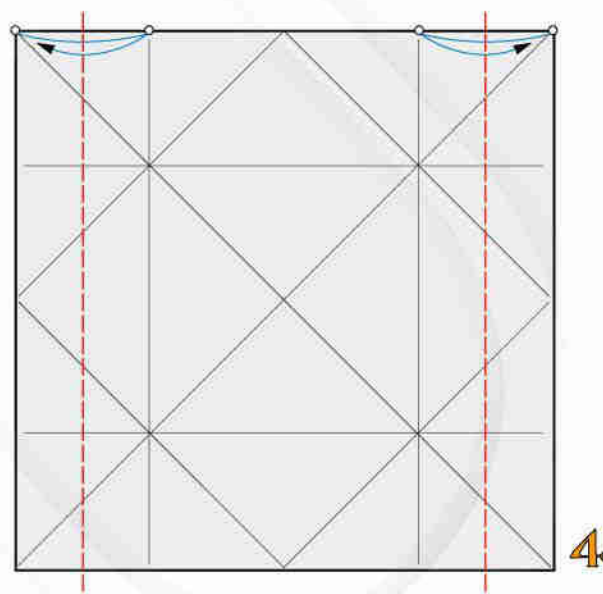

2 pieghe a valle

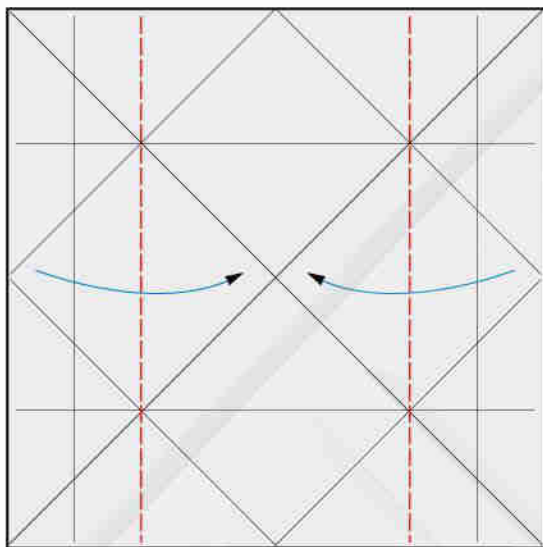

5

Ruotate ripiegando
4 volte a valle ed a
monte sulla sup. in
vista e 4 volte a valle
su quella sottostante

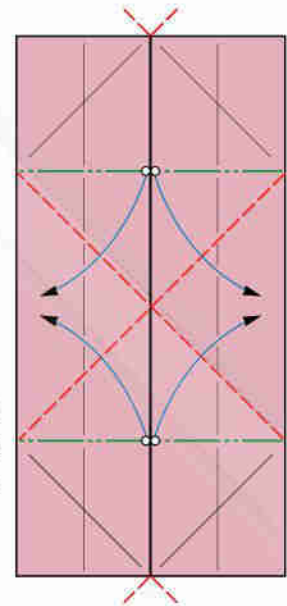

6

Ruotate ripiegando
a valle

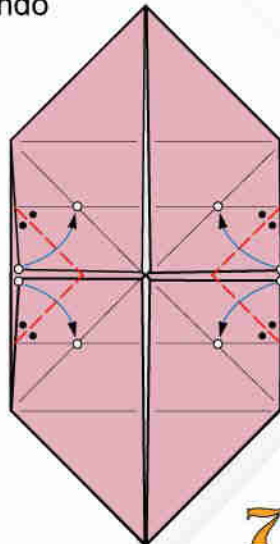

4 pieghe bisettrici
a valle e ruotate

7

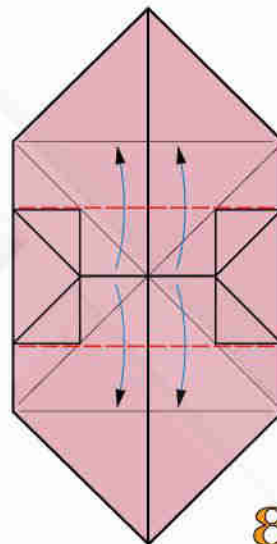

4 pieghe a
valle e ruotate

8

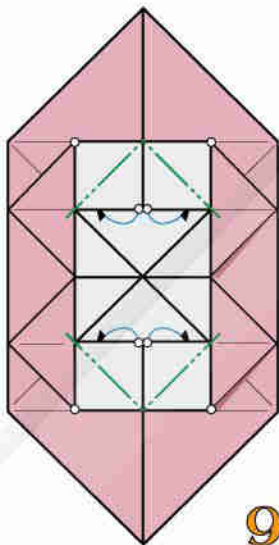

9

4 pieghe a monte e ruotate

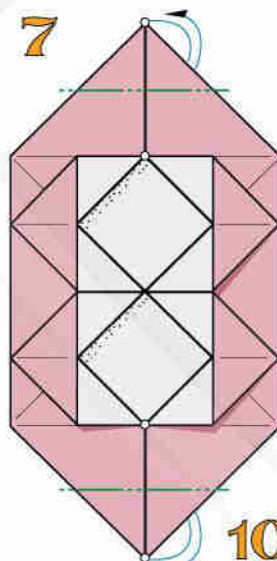

10

2 pieghe a monte

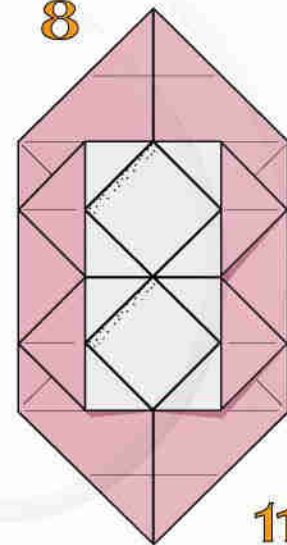

11

Modulo "C" ultimato

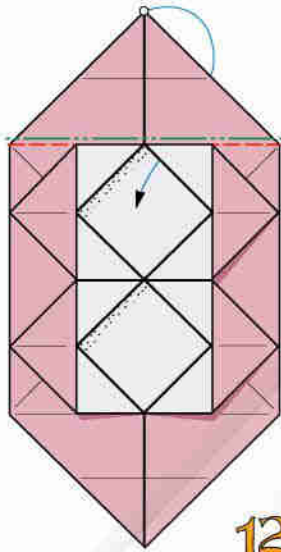

12

Modulo "E" di bordo:
eseguite una piega
rovescia interna

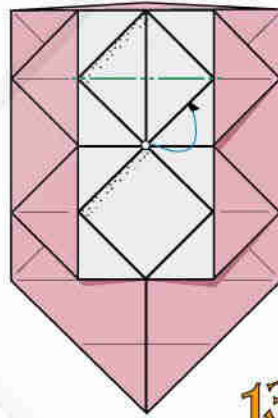

13

Mediante 1 piega a monte
ruotate all'interno il vertice
superiore

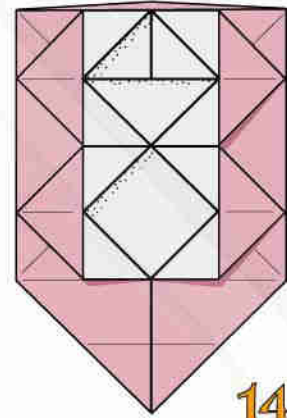

14

Modulo "E" di bordo
ultimato

UNIONE DI 2 MODULI

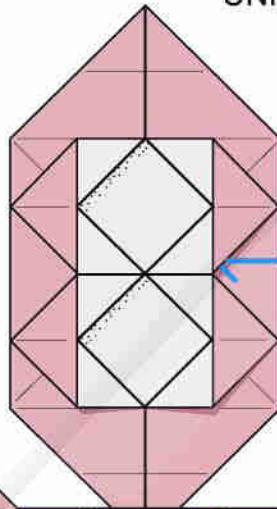

1

Intascate un modulo
nell'altro

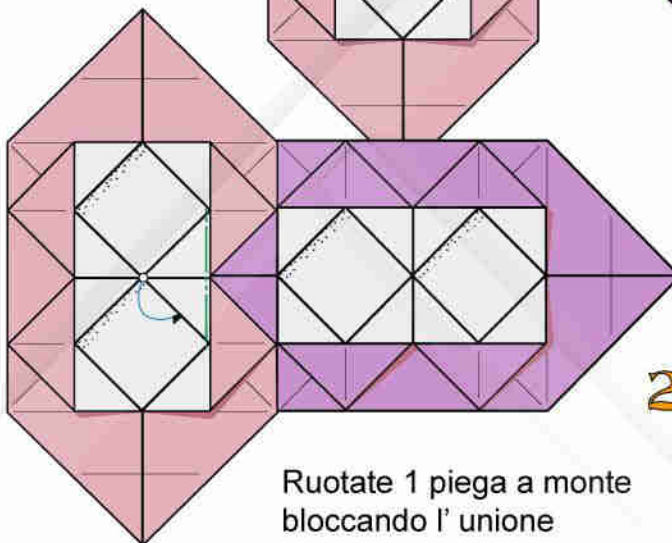

2

Ruotate 1 piega a monte
bloccando l'unione

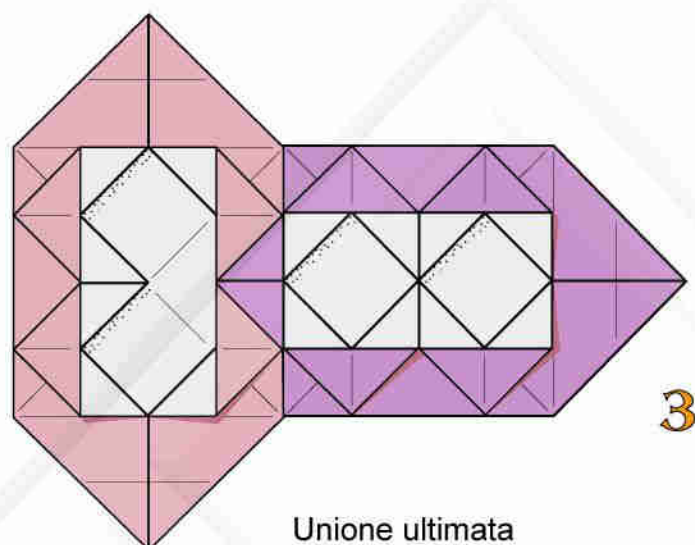

Unione ultimata

ESEMPIO DI TASSELLAZIONE ESEGUITA CON 16 MODULI "C"

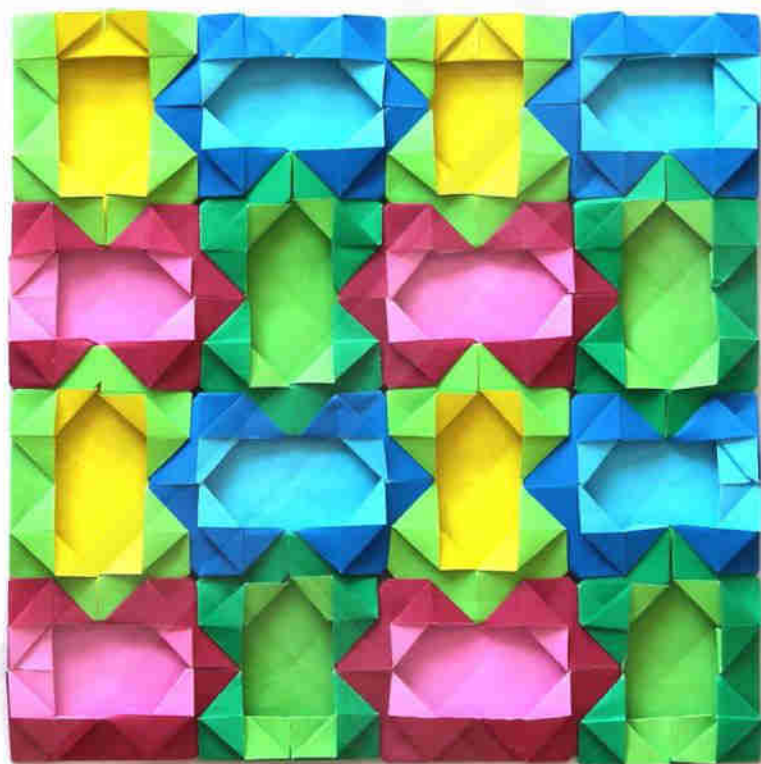

MODULO "D"

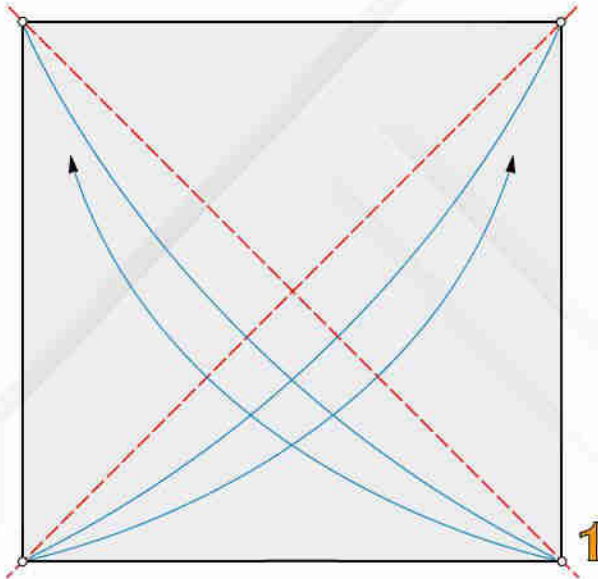

2 pieghe diagonali a valle

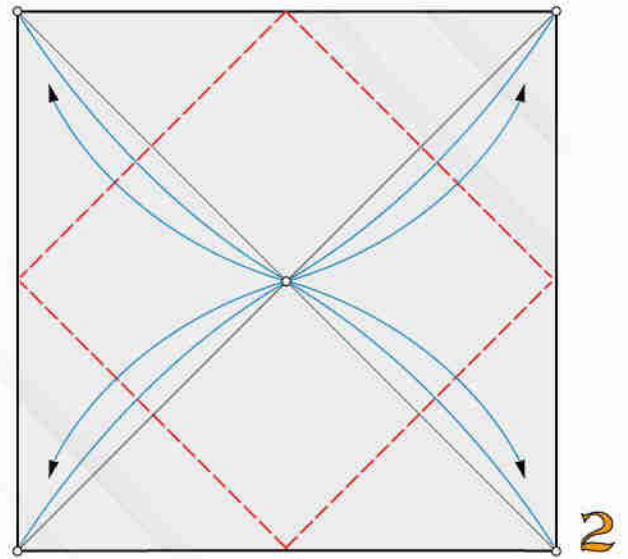

4 pieghe a valle

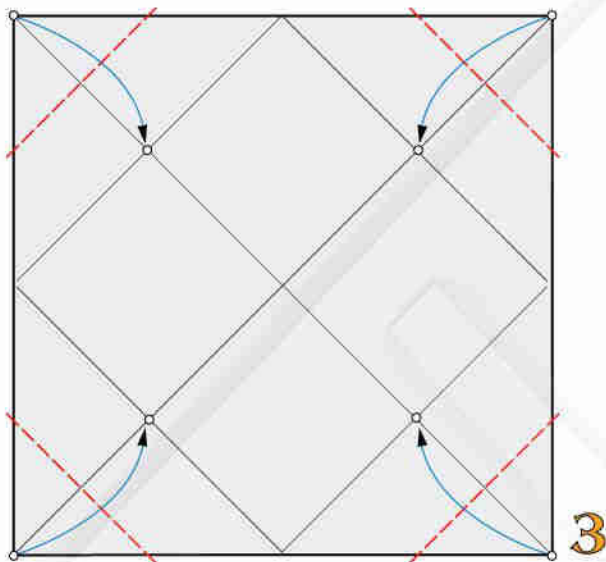

4 pieghe a valle e ruotate

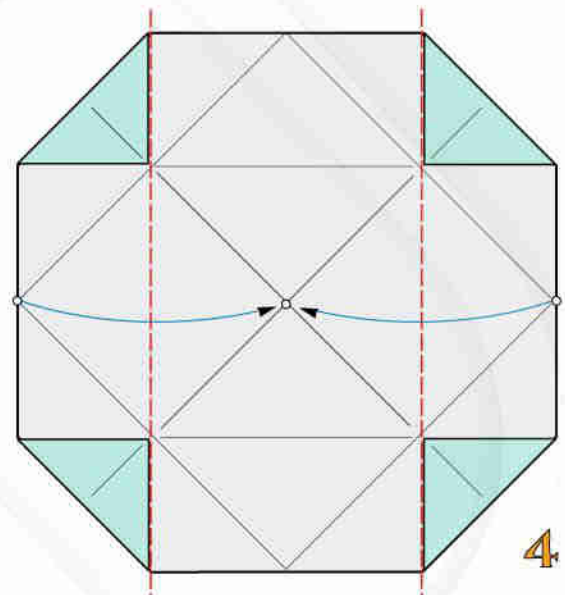

2 pieghe a valle e ruotate

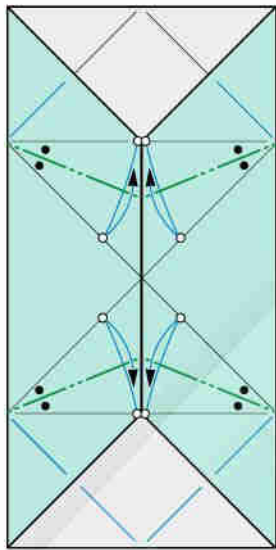

5

2 pieghe bisettrici a monte solo sulla sup. in vista

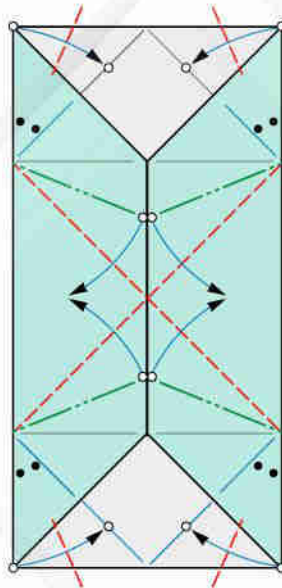

6

4 pieghe bisettrici a valle e ruotate ripiegando a valle ed a monte

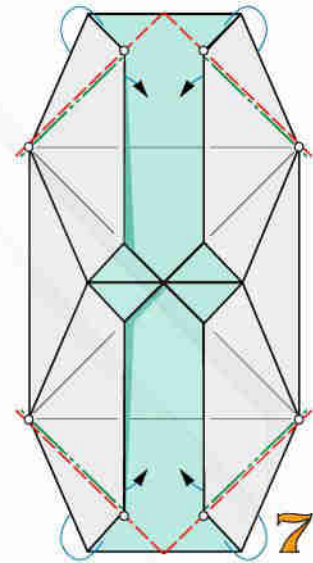

7

4 pieghe rovesce interne

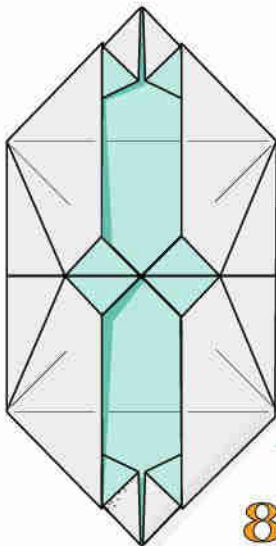

8

Modulo "D" ultimato. Ribaltate

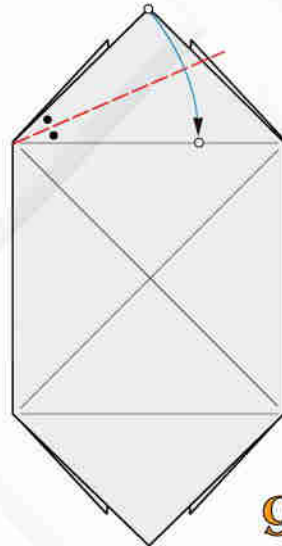

9

Modulo "D" di bordo: eseguite 1 piega a valle e ruotate

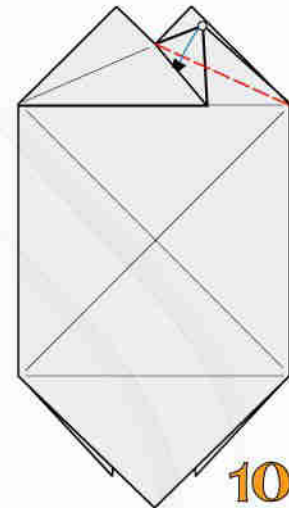

10

Eseguite 1 piega a valle ed intascate

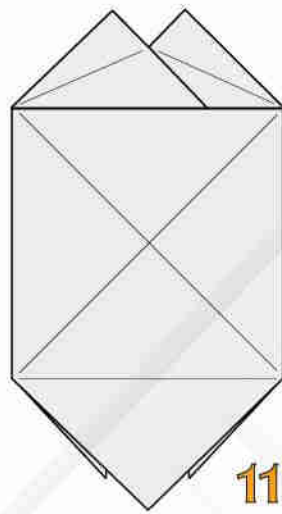

Ribaltate

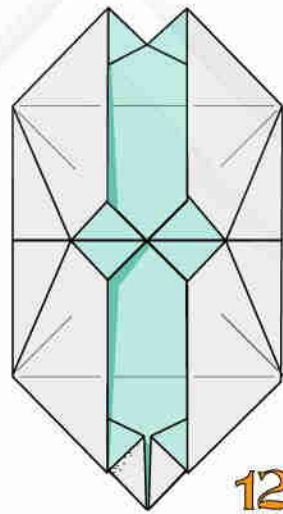

Modulo "D" di bordo ultimato.

UNIONE DI 2 MODULI

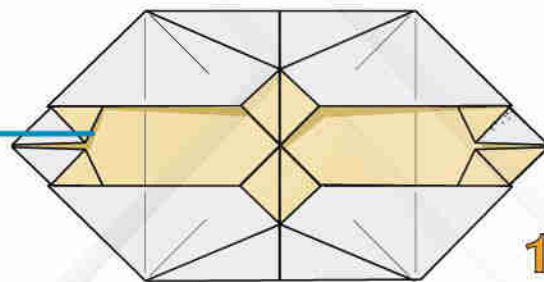
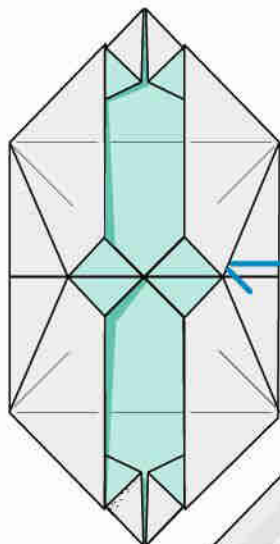

Intascate un modulo nell'altro

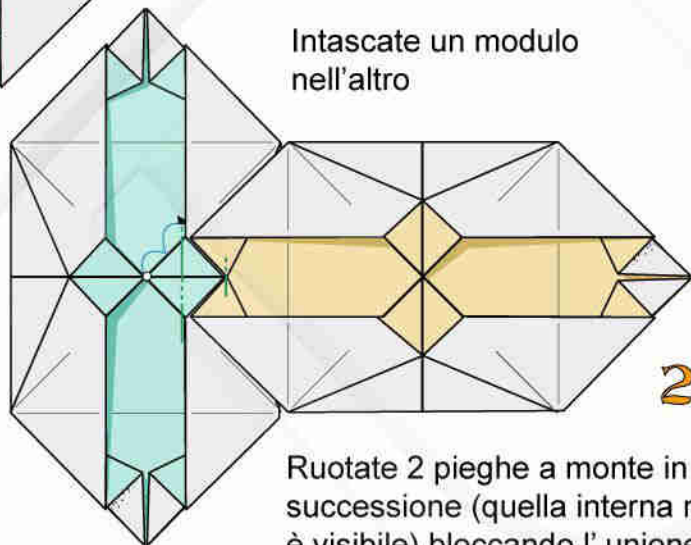

Ruotate 2 pieghe a monte in successione (quella interna non è visibile) bloccando l'unione

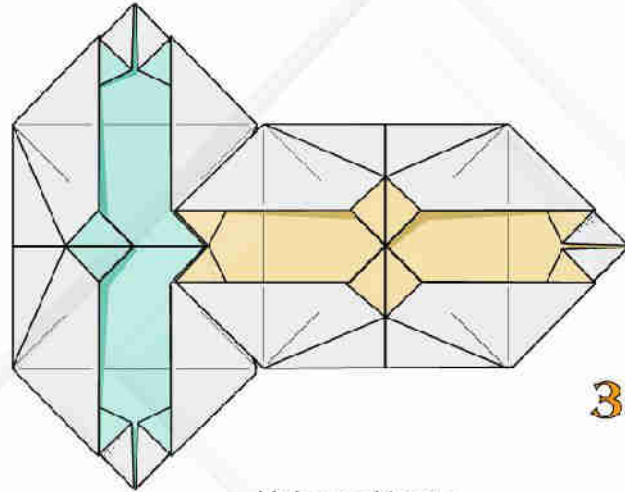

3

Unione ultimata

ESEMPIO DI TASSELLAZIONE ESEGUITA CON 16 MODULI "D"

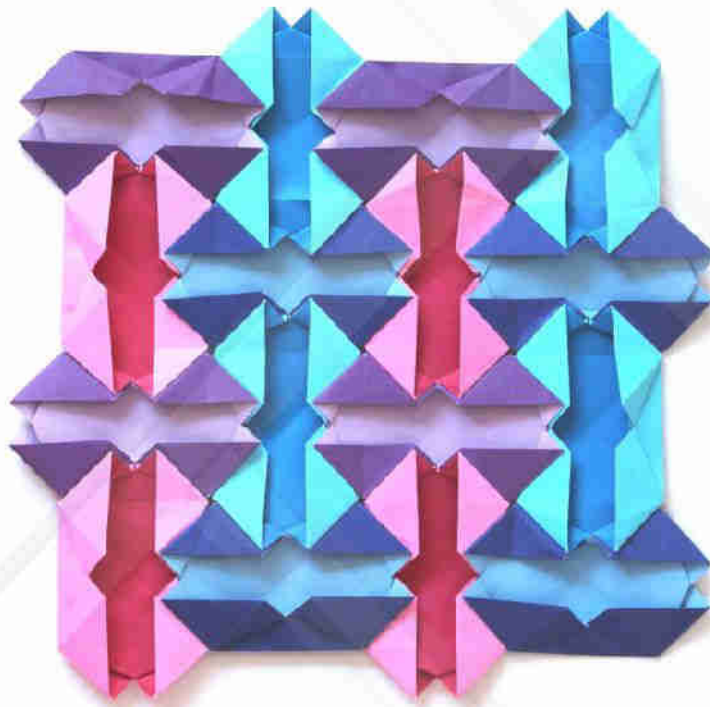

49

MODULO "FIORE"

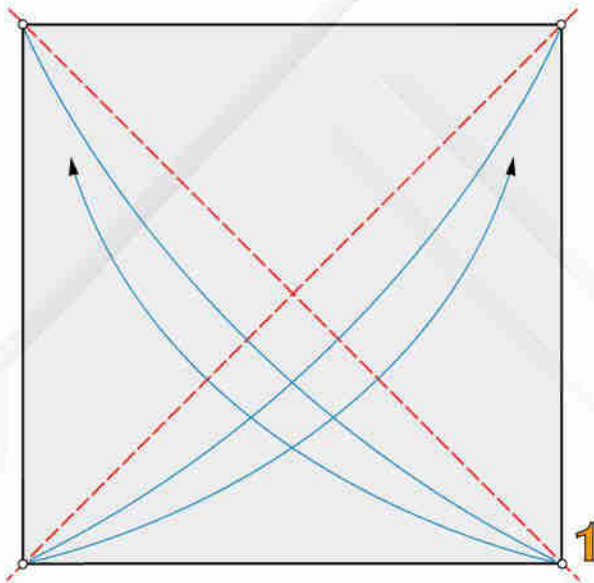

2 pieghe diagonali a valle

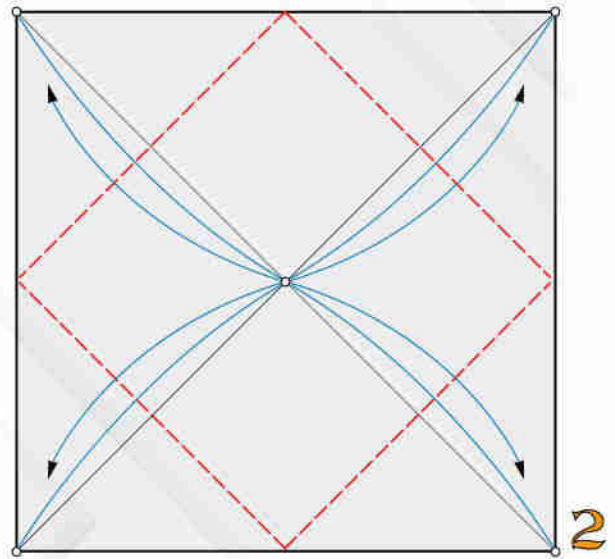

4 pieghe a valle

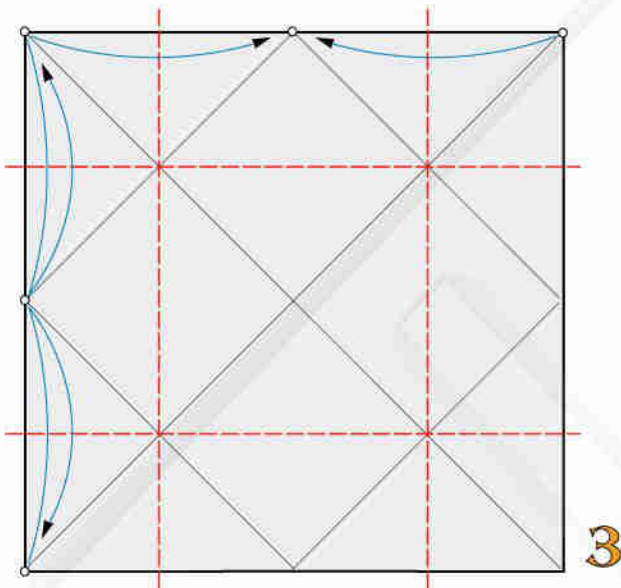

4 pieghe a valle e ruotate i bordi laterali

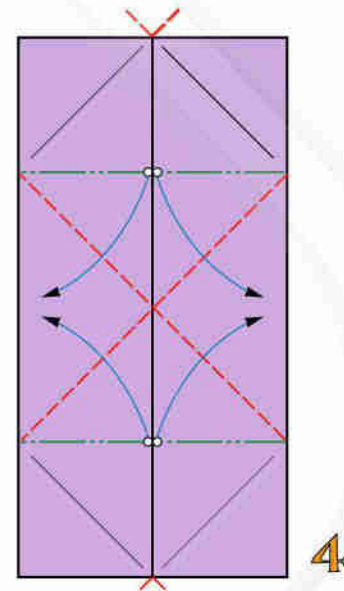

Ruotate ripiegando 4 volte a valle ed a monte sulla sup. in vista e 4 volte a valle su quella sottostante

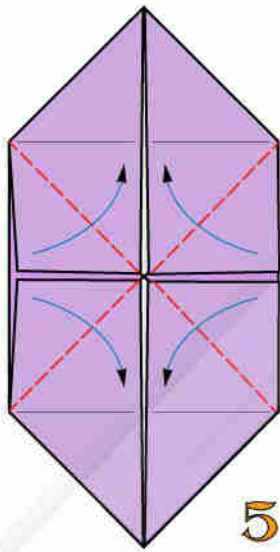

5

4 pieghe a valle e ruotate

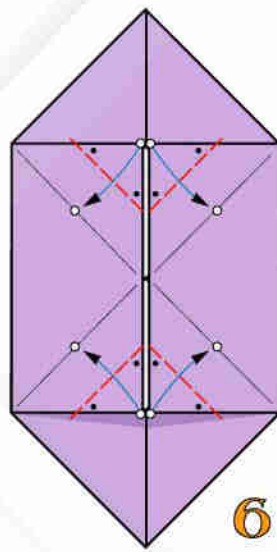

6

4 pieghe a valle e ruotate

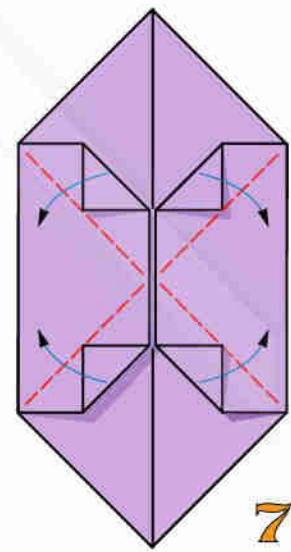

7

Ripiegando a valle, ruotate

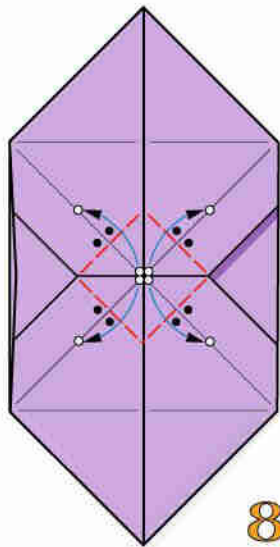

8

4 pieghe a valle e ruotate

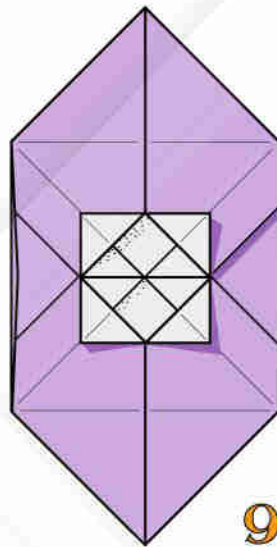

9

Modulo "Fiore" ultimato.

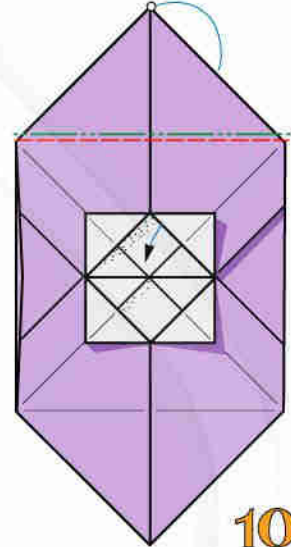

10

Modulo "Fiore" di bordo:
eseguite una piega
rovescia interna

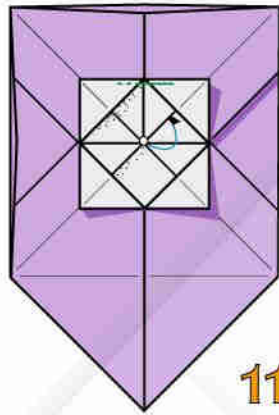

11

Mediante 1 piega a monte ruotate all'interno il vertice superiore

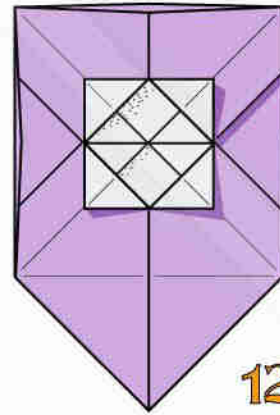

12

Modulo "Fiore" di bordo ultimato

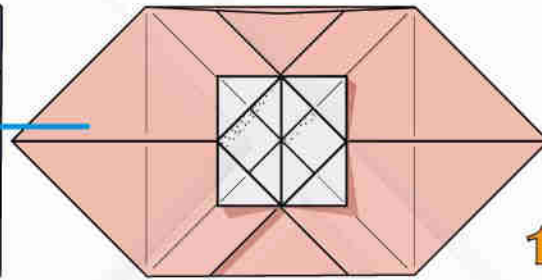
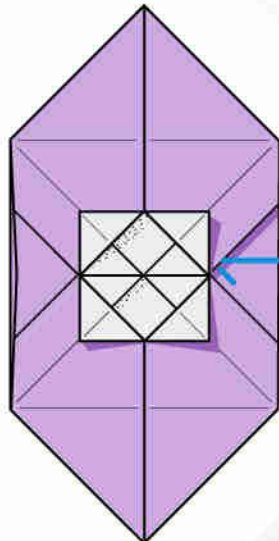

1

Intascate un modulo nell'altro

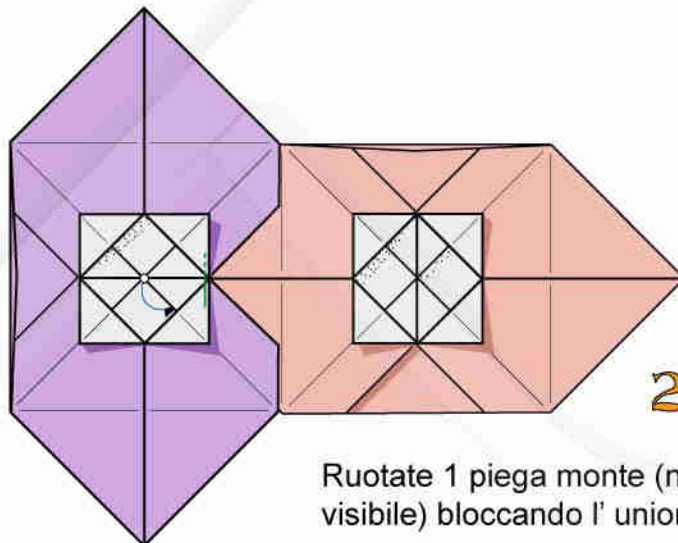

2

Ruotate 1 piega monte (non visibile) bloccando l'unione

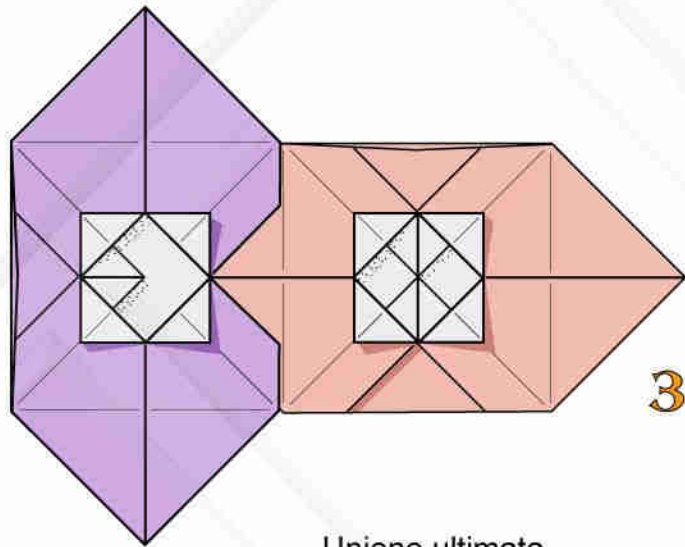

Unione ultimata

ESEMPIO DI TASSELLAZIONE ESEGUITA CON 16 MODULI "FIORE"

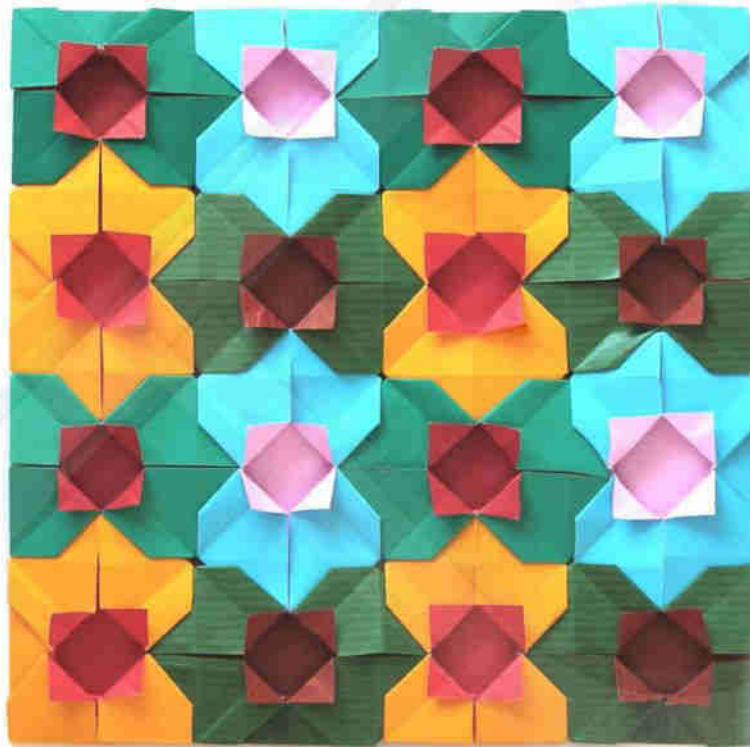

MODULO "€"

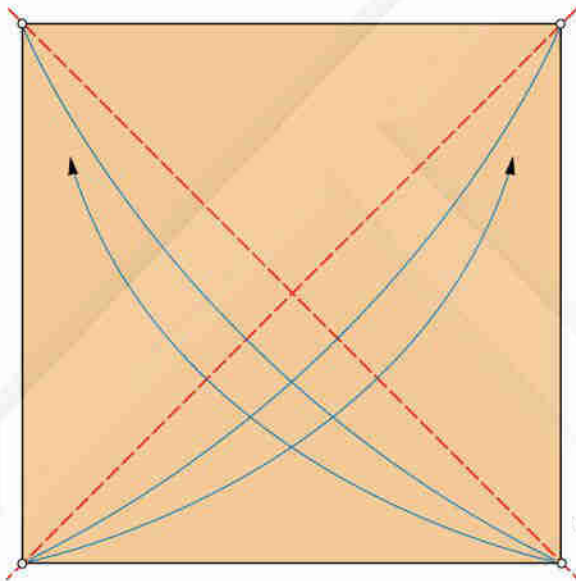

2 pieghe diagonali a valle

1

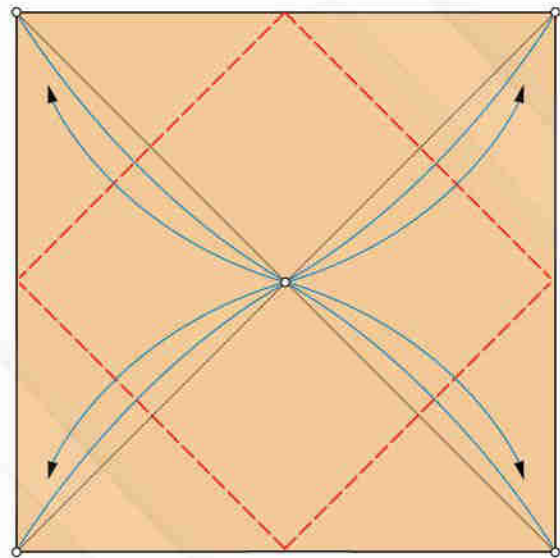

4 pieghe a valle

2

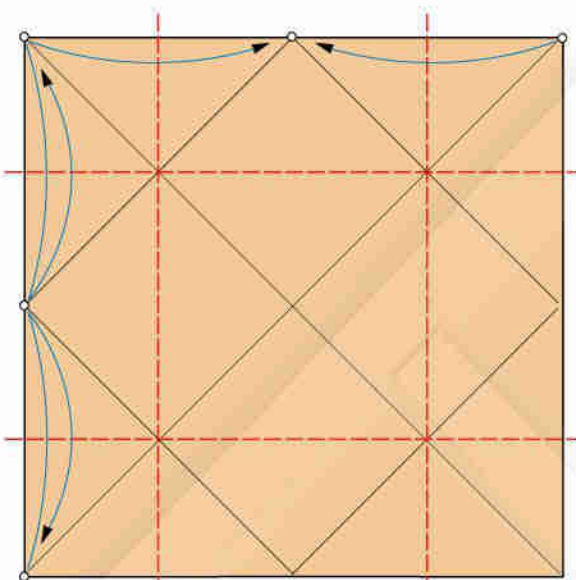

4 pieghe a valle e ruotate i bordi laterali

3

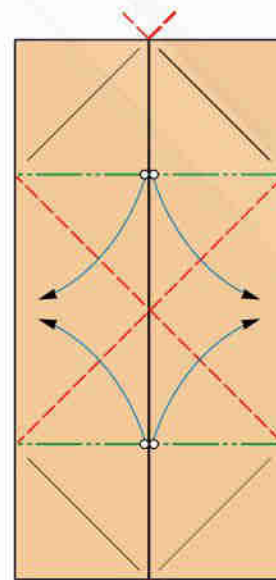

Ruotate ripiegando 4 volte a valle ed a monte sulla sup. in vista e 4 volte a valle su quella sottostante

4

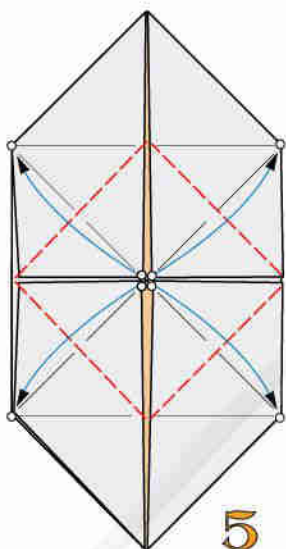

4 pieghe a valle e ruotate

5

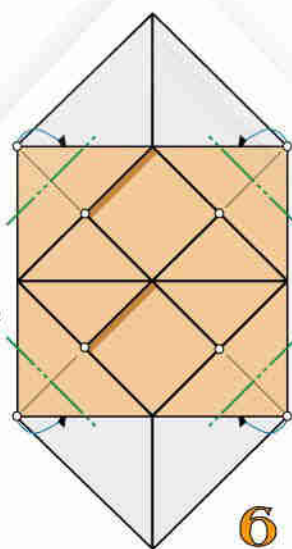

4 pieghe a monte e ruotate

6

4 pieghe a monte e ruotate

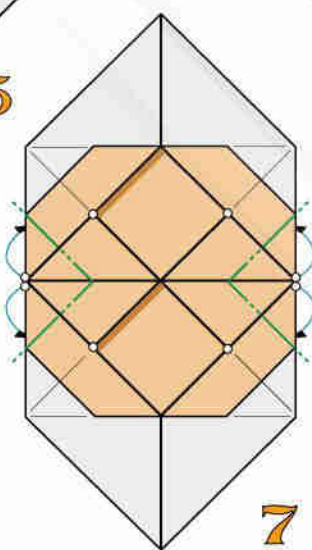

Modulo "E" ultimato

7

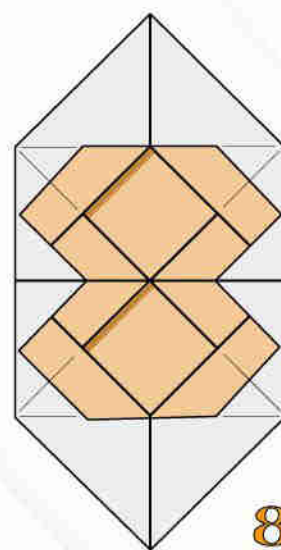

8

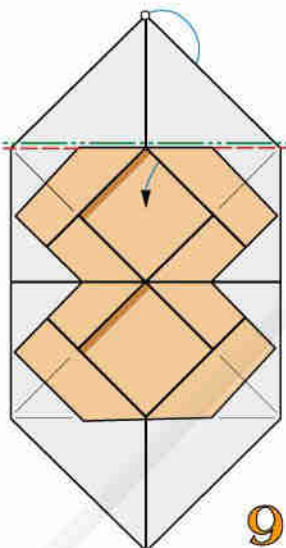

Modulo "E" di bordo: eseguite una piega rovescia interna

9

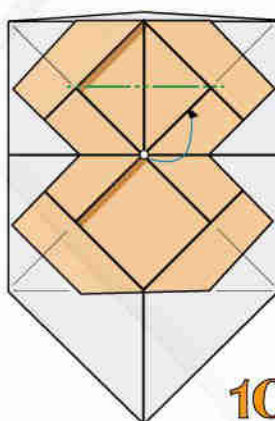

Mediante 1 piega a monte ruotate all'interno il vertice superiore

10

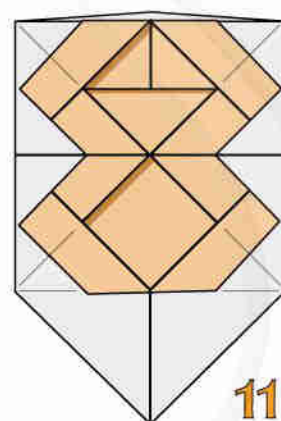

Modulo "E" di bordo ultimato

11

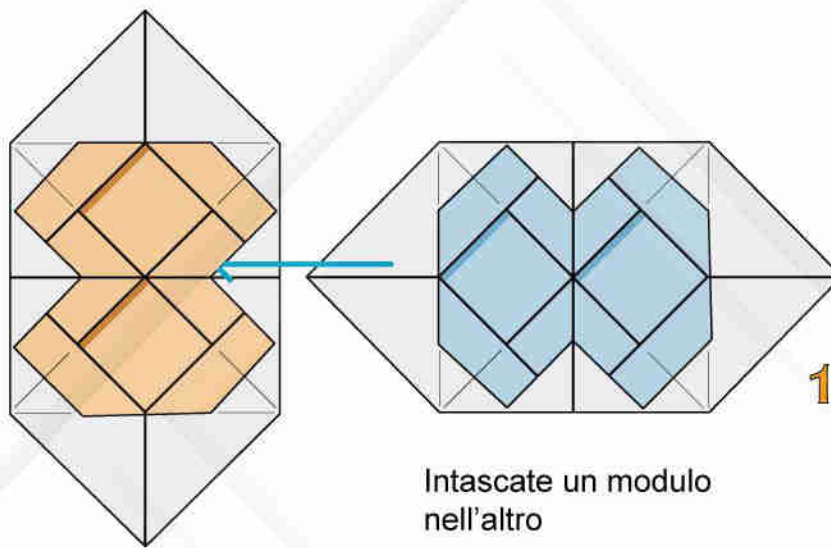

Intascate un modulo nell'altro

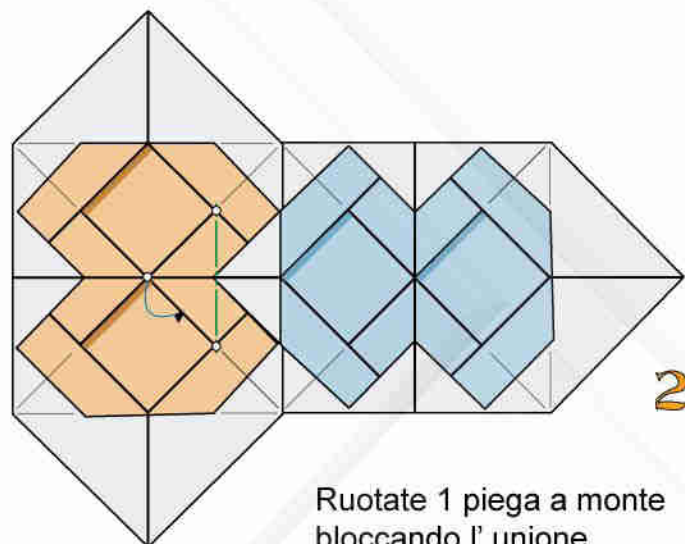

Ruotate 1 piega a monte bloccando l'unione

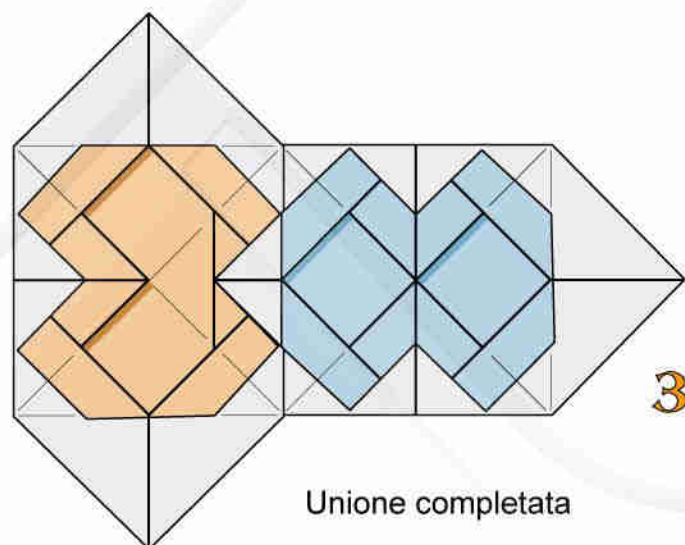

Unione completata

ESEMPIO DI TASSELLAZIONE ESEGUITA CON 16 MODULI "D"

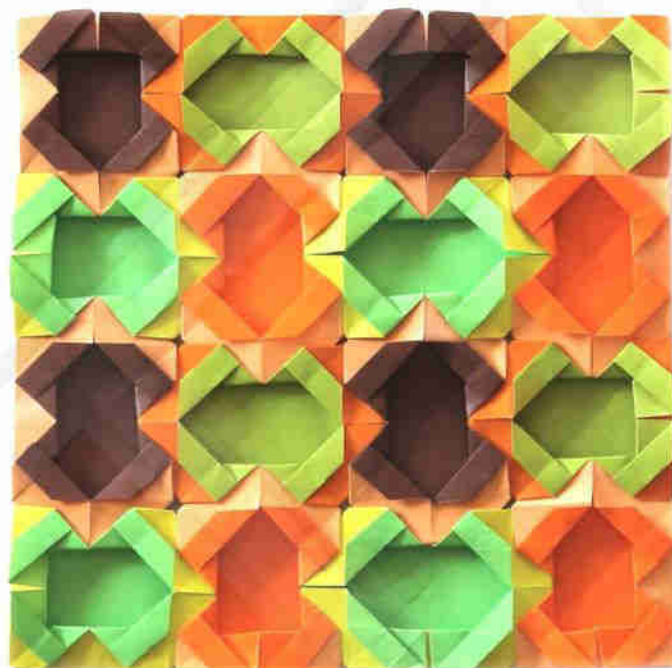

ESEMPIO DI TASSELLAZIONE MISTA, ESEGUITA CON 8 MODULI "FIORE", 4 MODULI "A" E 4 MODULI "E"



MODULI RETTANGOLARI VARIABILI

Si presentano 2 moduli, compatibili tra loro, estremamente flessibili, tanto da permettere quasi ogni possibile trama ortogonale.

Ambedue si realizzano partendo da fogli rettangolari 2x1.

Il modulo "A" è asimmetrico, con un'estremità a gancio e all'altra estremità 3 ganci o 3 tasche; il modulo "B" può avere indifferentemente 6 ganci o 6 tasche equamente ripartiti nel perimetro.



Modulo rettangolare "A"

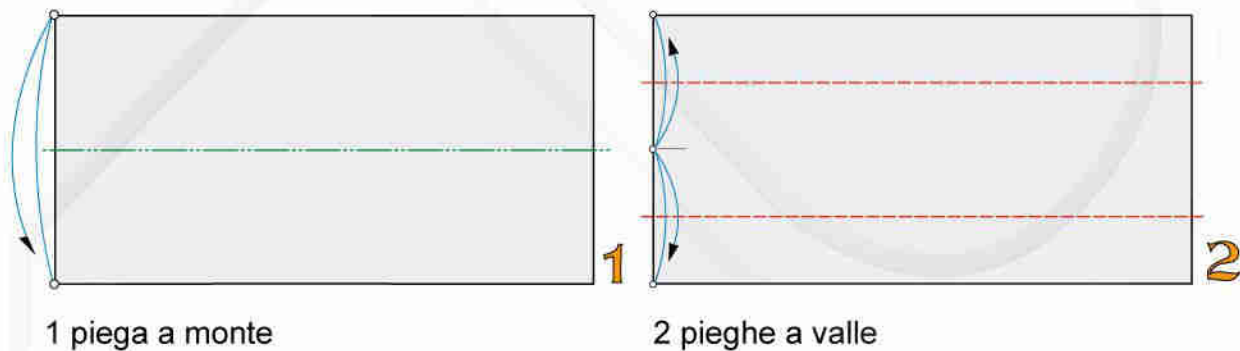

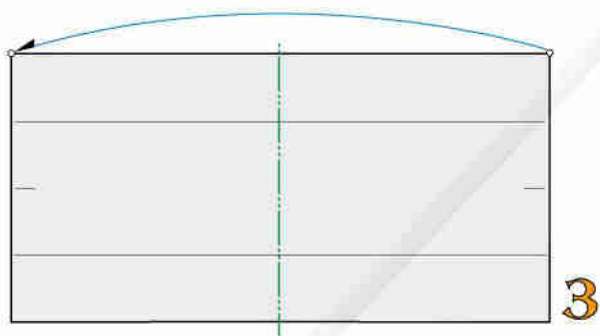

1 piega a monte

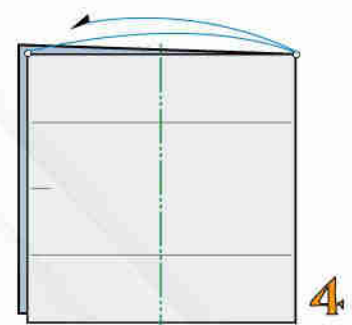

1 piega a monte solo sulla sup. in vista

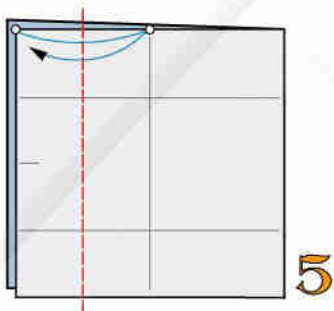

1 piega a valle solo sulla sup. in vista

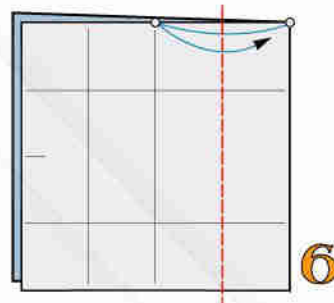

1 piega a valle solo sulla sup. in vista

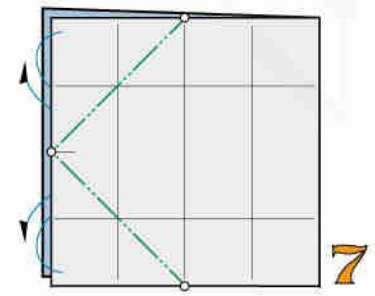

2 pieghe a monte solo sulla sup. in vista

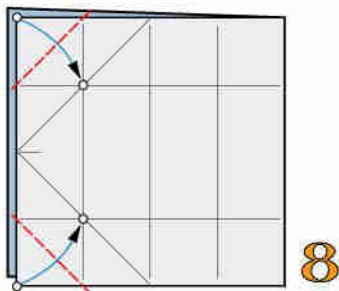

2 pieghe a valle e ruotate

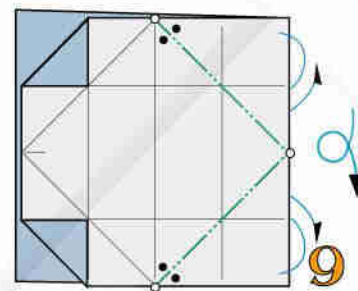

2 pieghe bisettrici a monte e ribaltate

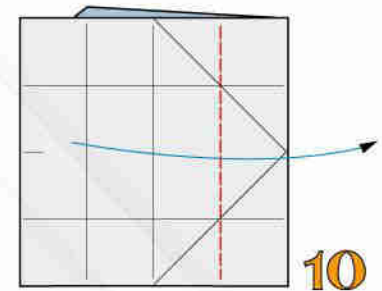

Ruotate ripiegando a valle

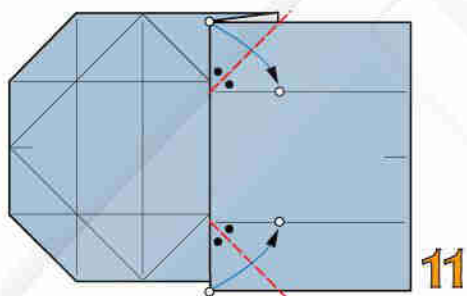

2 pieghe bisettrice valle e ruotate

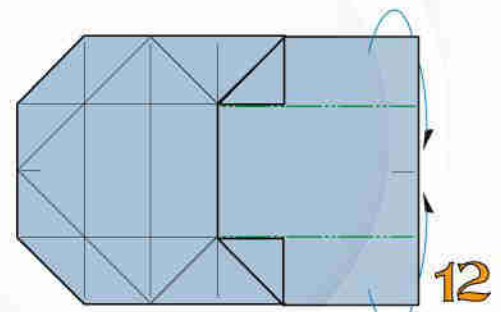

2 pieghe a monte e ruotate

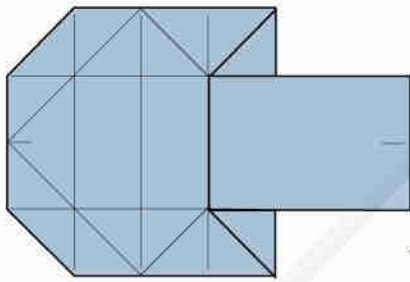

13

Ribaltate

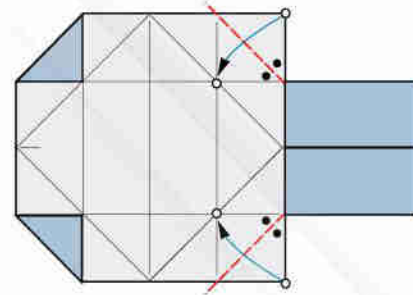

14

2 pieghe a valle e ruotate

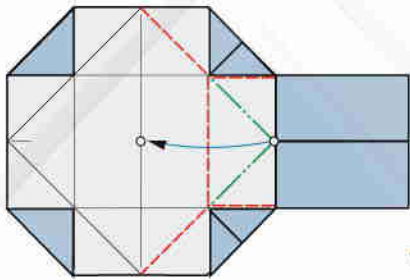

15

Ruotate ripiegando a valle ed a monte

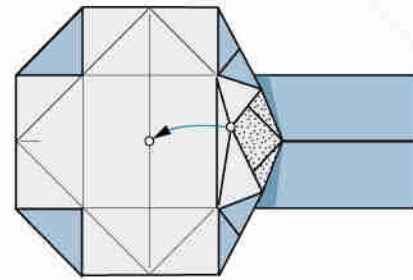

16

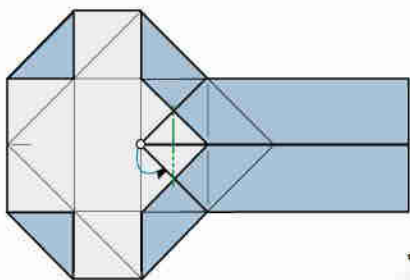

17

1 piega a monte e ruotate bloccando il modello

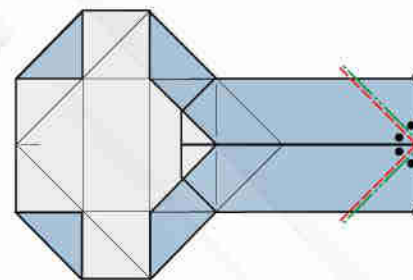

18

2 pieghe rovesce interne

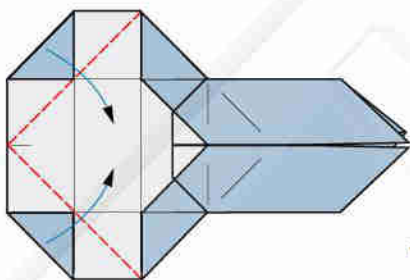

19

Ruotate ripiegando a valle

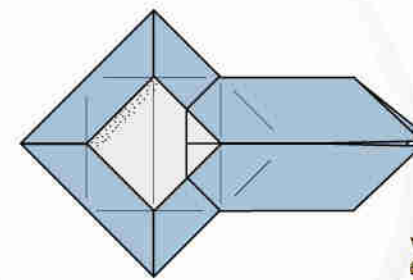

20

Modulo rettangolare A ultimato con 4 ganci

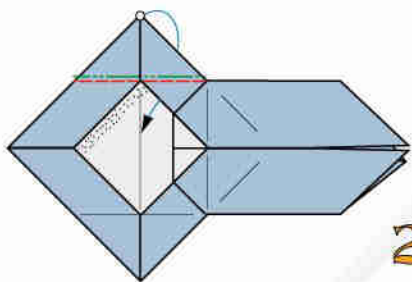

21

Eseguite 1 piega rovescia interna

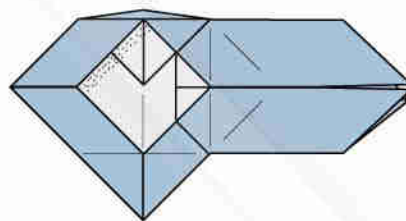

MODULO "A1" ultimato
con 3 ganci e 1 tasca

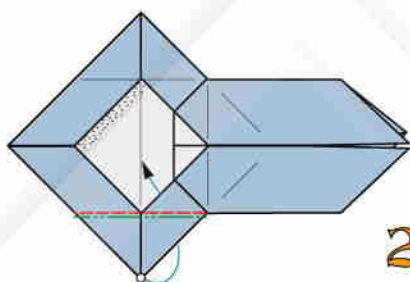

22

Eseguite 1 piega rovescia interna

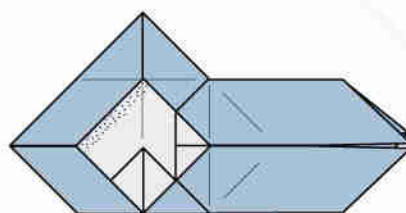

MODULO "A2" ultimato
con 3 ganci e 1 tasca

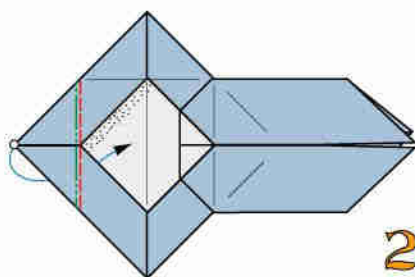

23

Eseguite 1 piega rovescia interna

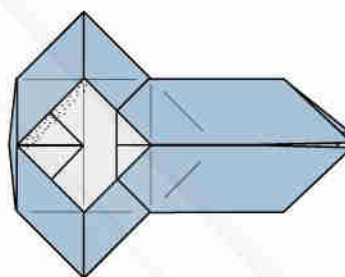

MODULO "A3" ultimato
con 3 ganci e 1 tasca

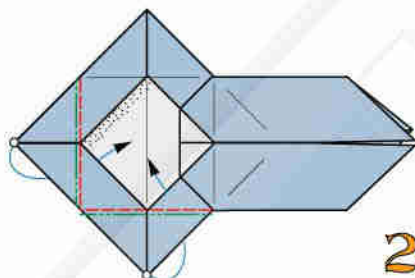

24

Eseguite 2 pieghe rovesce interne

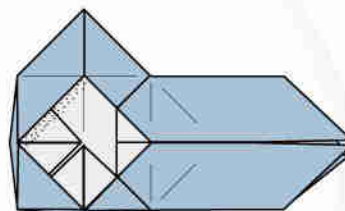

MODULO "A4" ultimato
con 2 ganci e 2 tasche

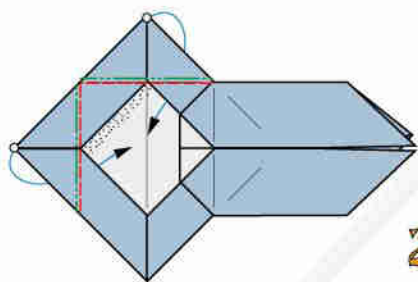

25

Eseguite 2 pieghe rovesce interne

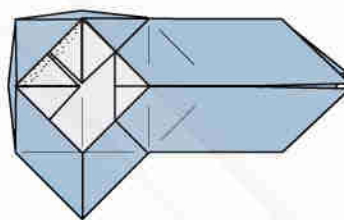

MODULO "A5" ultimato
con 2 ganci e 2 tasche

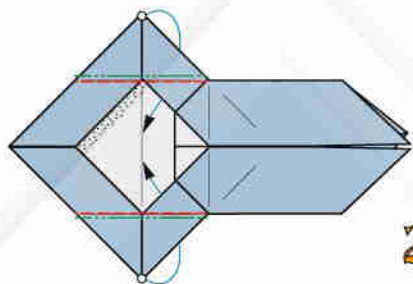

26

Eseguite 2 pieghe rovesce interne

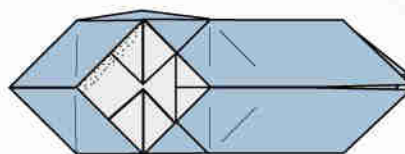

MODULO "A6" ultimato
con 2 ganci e 2 tasche

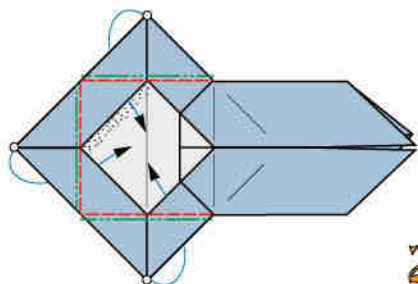

27

Eseguite 3 pieghe rovesce interne

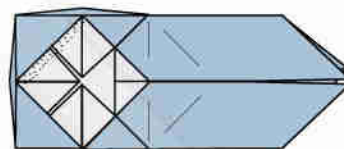

MODULO "A7" ultimato
con 1 gancio e 3 tasche

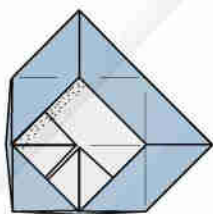

A volte può essere utile disporre di un mezzo modulo, ottenuto dividendo a metà il foglio rettangolare base.
MEZZO MODULO "A4" ultimato con 2 ganci e 2 tasche.

UNIONE DI MODULI A4

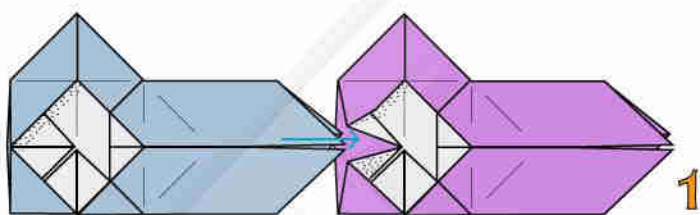

Inserite tutti i 3 vertici del modulo di sinistra nella tasca del modulo di destra

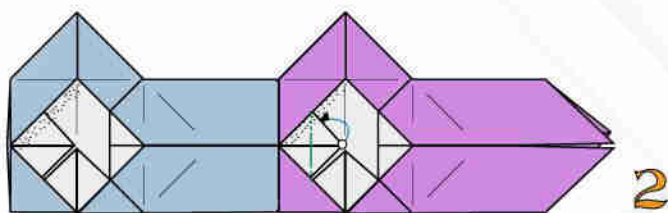

Ruotate una piega a monte bloccando l'unione

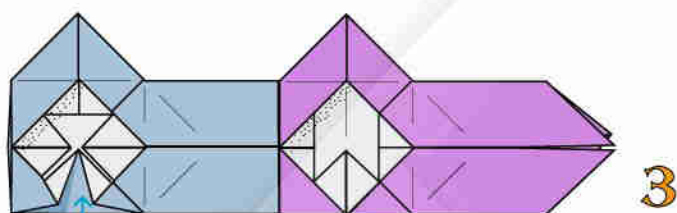

Inserite e bloccate un terzo modulo

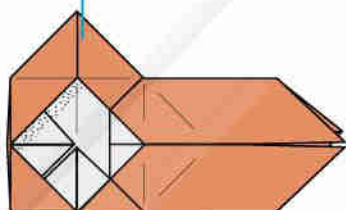

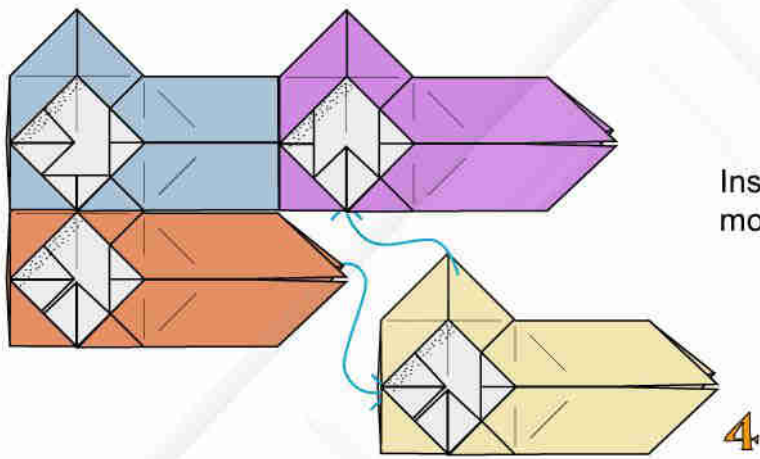

Inserite e bloccate un quarto
modulo

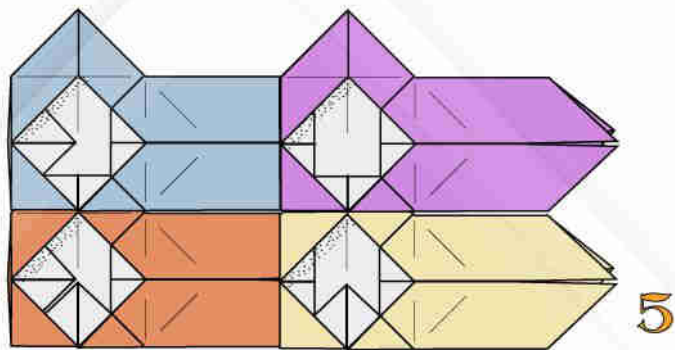

UNIONE DI 2 MODULI "A4", 2 "A5", E 2 MEZZI MODULI

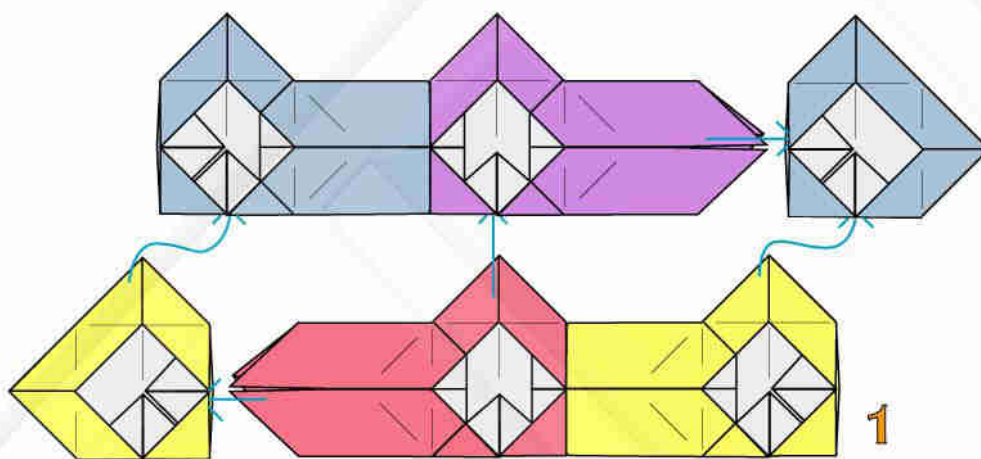

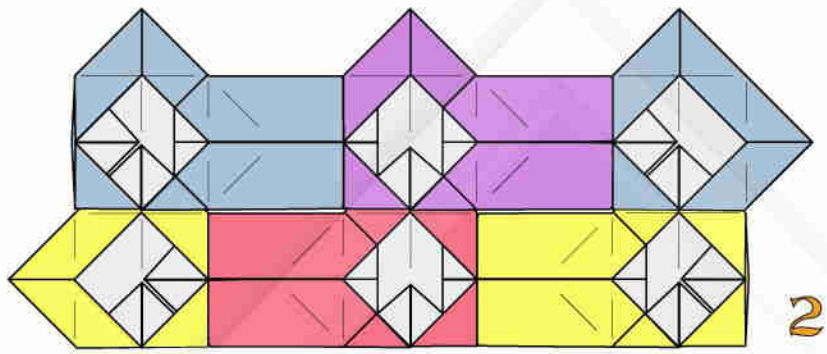

UNIONE DI 4 MODULI "A4", 2 "A5", E 3 "A7"

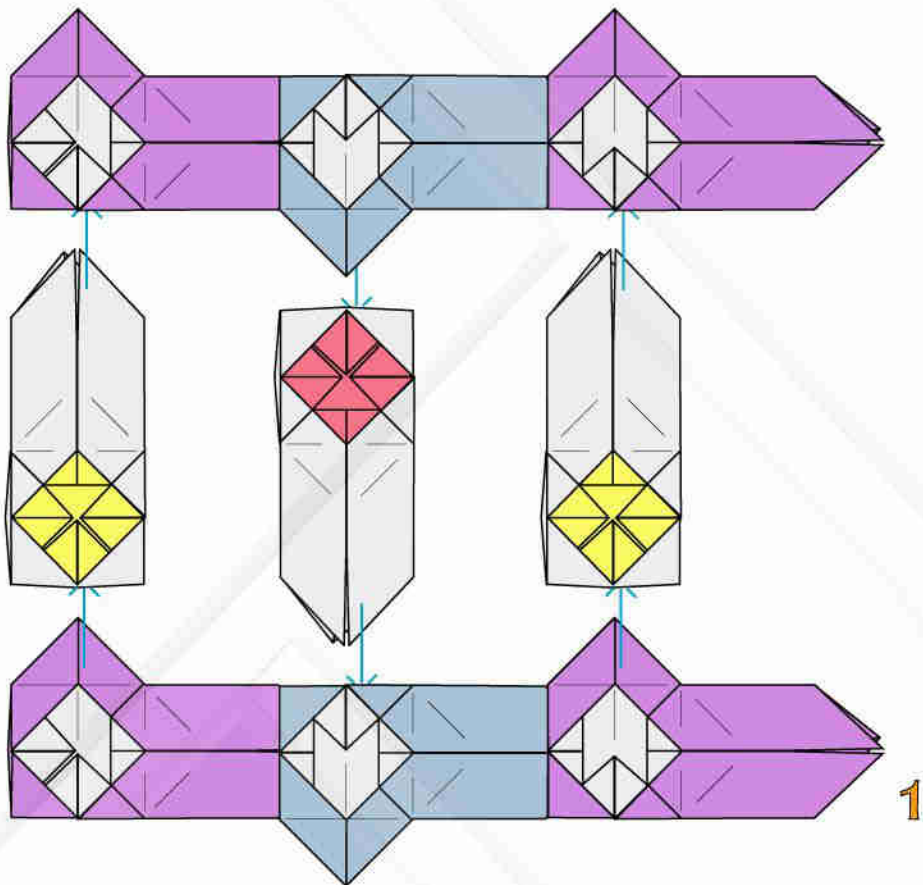

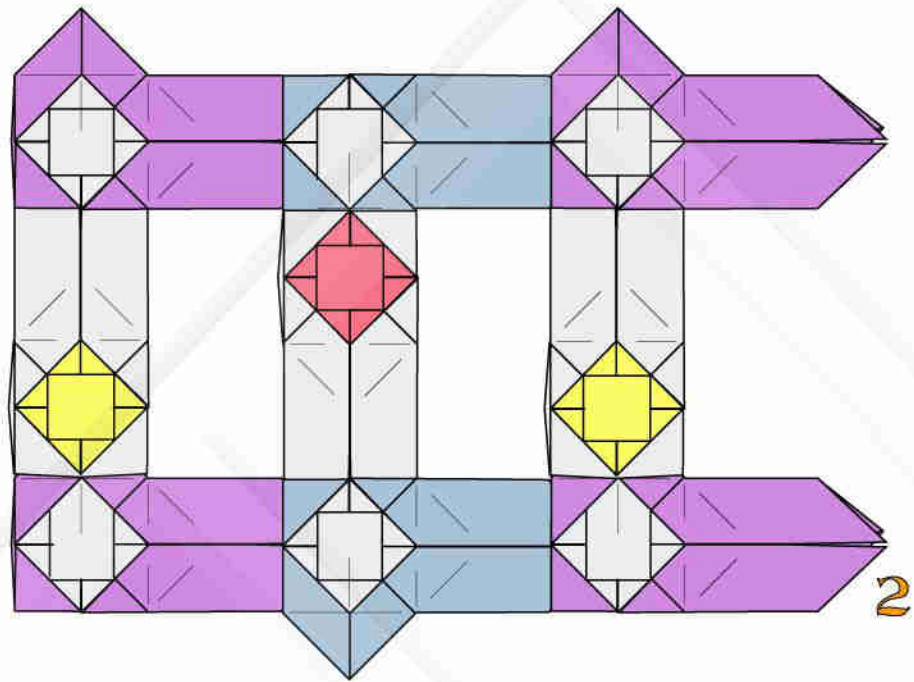

**ESEMPIO DI TASSELLAZIONE ESEGUITA
CON 16 MODULI "A5" E 8 MEZZI MODULI**

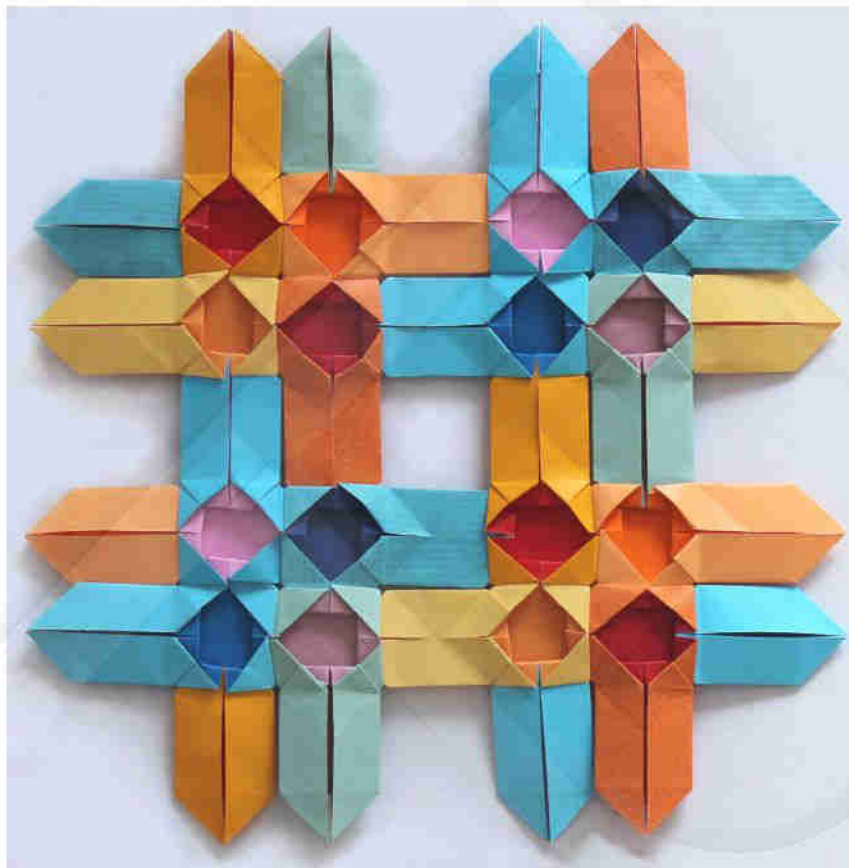

**ESEMPIO DI TASSELLAZIONE ESEGUITA
CON 12 MODULI "A4" E 4 MEZZI MODULI**



**ESEMPIO DI TASSELLAZIONE ESEGUITA
CON 9 MODULI "A4", 5 MODULI "A5" E 10
MEZZI MODULI**

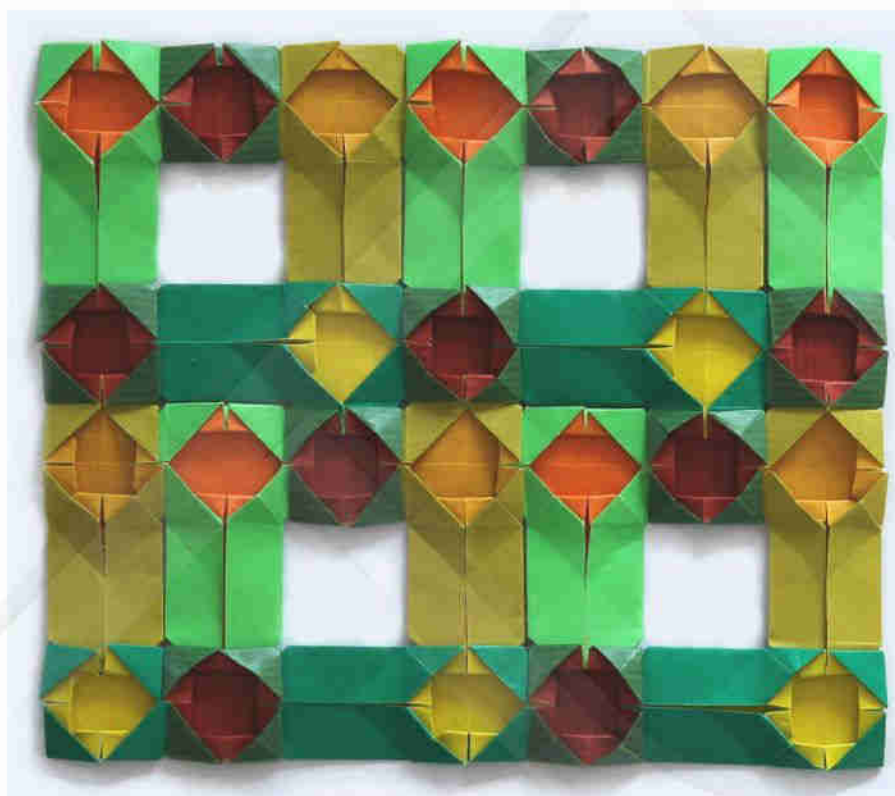

Modulo rettangolare B²



1

1 piega a monte



2

2 pieghe a valle

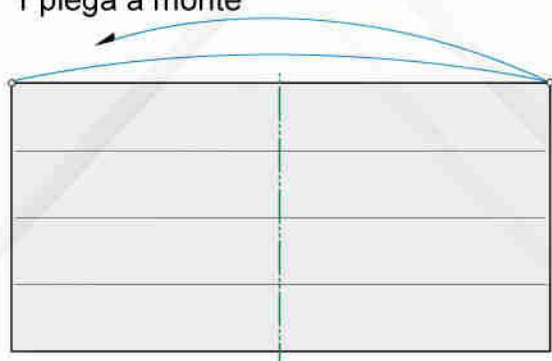

3

1 piega a monte

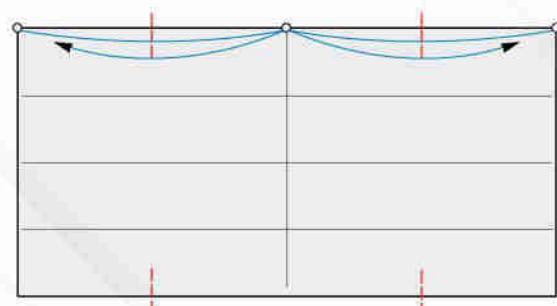

4

4 piccole pieghe a valle

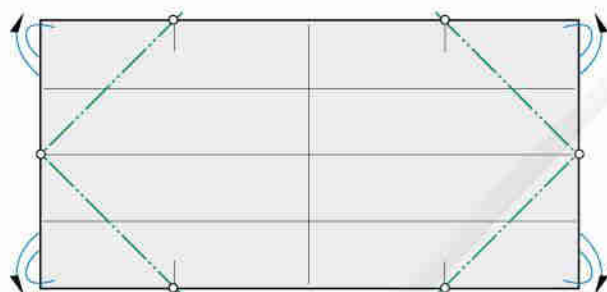

5

4 pieghe a monte

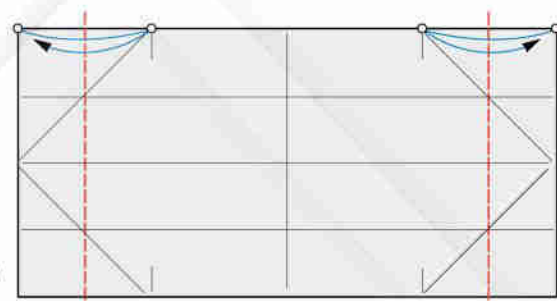

6

2 pieghe a valle



7

2 pieghe a valle

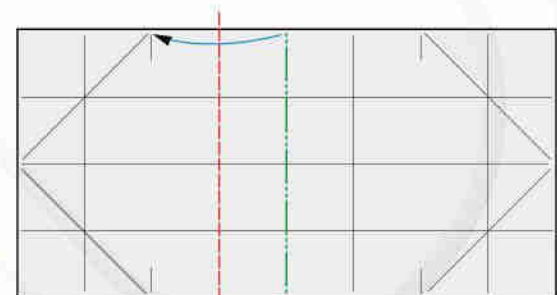

8

Ruotate ripiegando a valle ed a monte

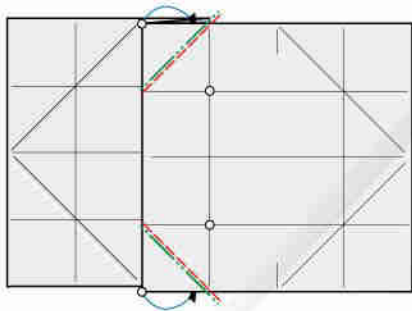

9

2 pieghe rovesce interne

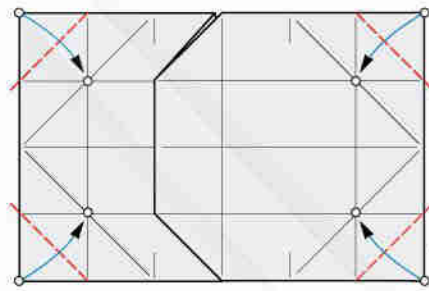

10

4 pieghe a valle e ruotate

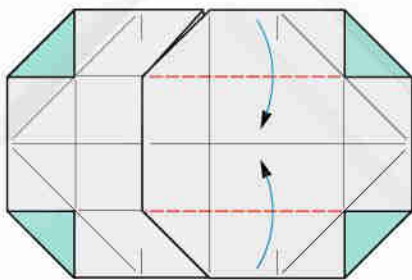

11

Ruotate ripiegando a valle

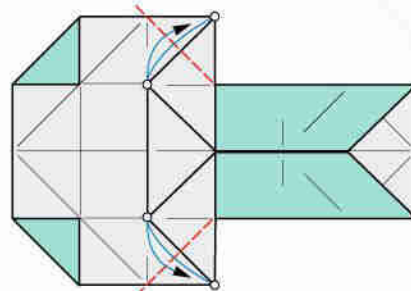

12

2 pieghe a valle

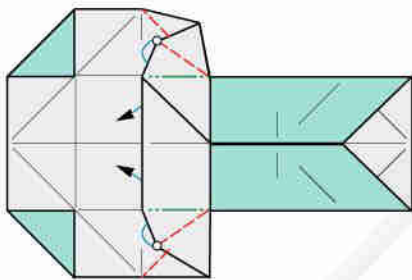

13

2 pieghe rovesce interne

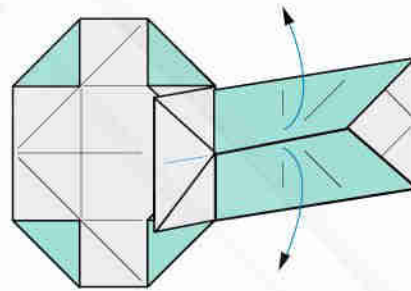

14

Riaprite

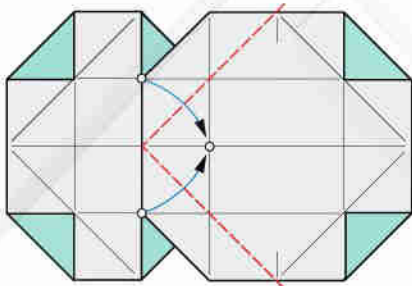

15

2 pieghe a valle

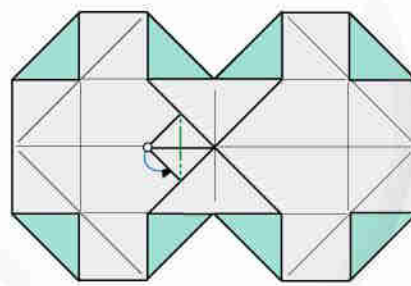

16

1 piega a monte e ruotate bloccando il modello

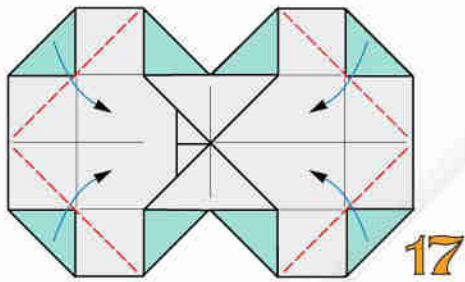

4 pieghe a valle e ruotate

17

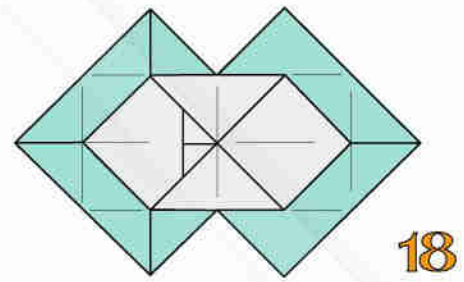

MODULO "B" ultimato
con 6 ganci

18

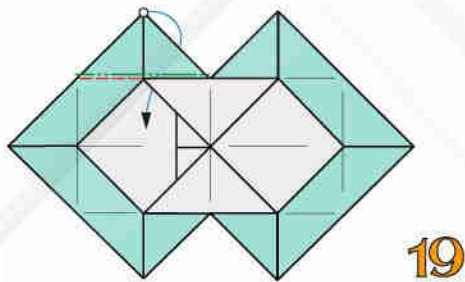

Modulo B.
Eseguite 1 piega rovescia interna

19

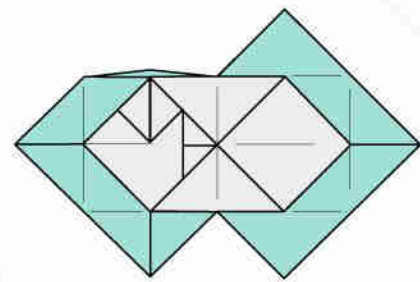

MODULO "B1" ultimato
con 5 ganci e 1 tasche

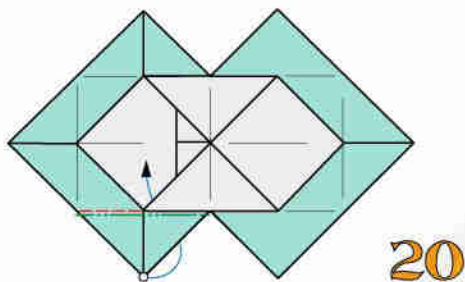

Modulo B.
Eseguite 1 piega rovescia interna

20

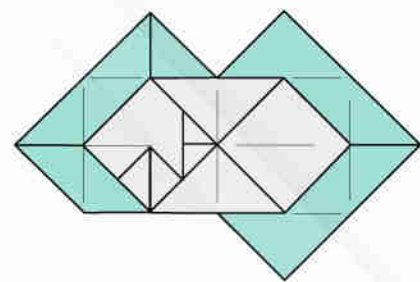

MODULO "B2" ultimato
con 5 ganci e 1 tasche

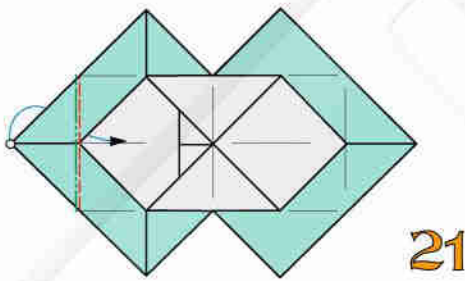

Modulo B.
Eseguite 1 piega rovescia interna

21

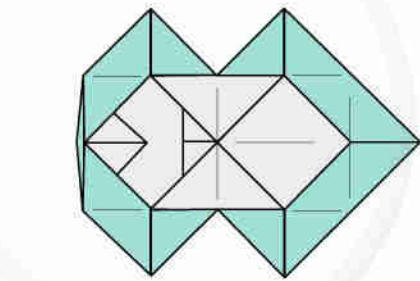

MODULO "B3" ultimato
con 5 ganci e 1 tasche

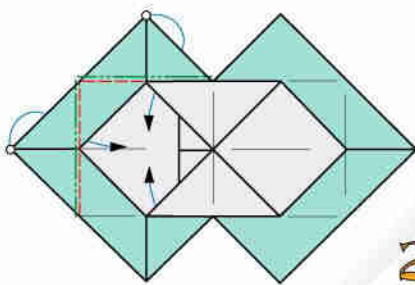

22

Modulo B.
Eseguite 2 pieghe rovesce interne

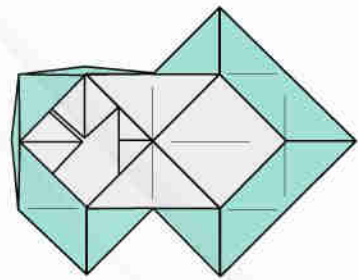

MODULO "B4" ultimato
con 5 ganci e 1 tasca

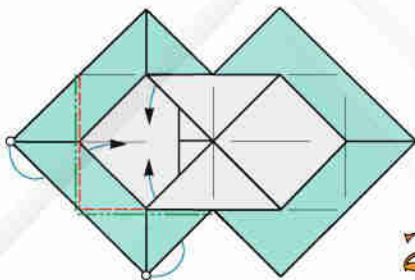

23

Modulo B.
Eseguite 2 pieghe rovesce interne

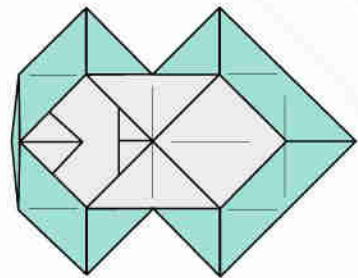

MODULO "B5" ultimato
con 5 ganci e 1 tasca

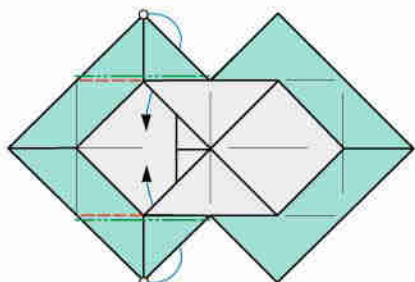

24

Modulo B.
Eseguite 2 pieghe rovesce interne

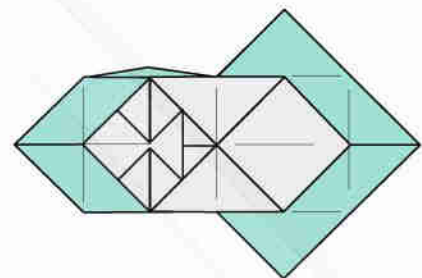

MODULO "B6" ultimato
con 5 ganci e 1 tasca

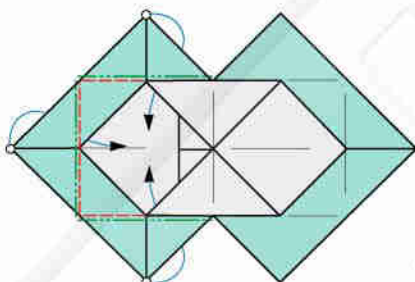

25

Modulo B.
Eseguite 3 pieghe rovesce interne

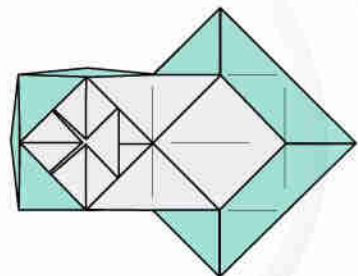

MODULO "B7" ultimato
con 5 ganci e 1 tasca

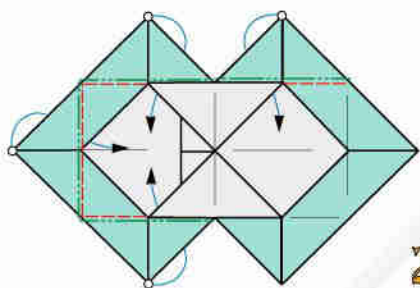

26

Modulo B.
Eseguite 4 pieghe rovesce interne

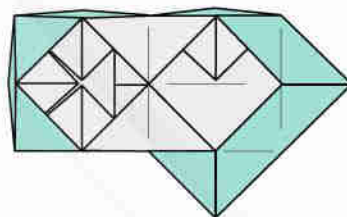

MODULO "B8" ultimato
con 2 ganci e 4 tasche

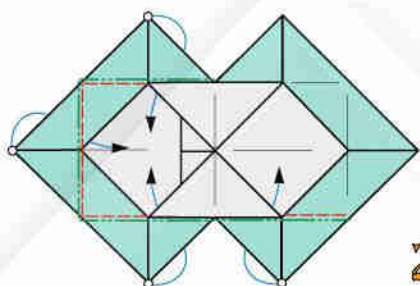

27

Modulo B.
Eseguite 4 pieghe rovesce interne

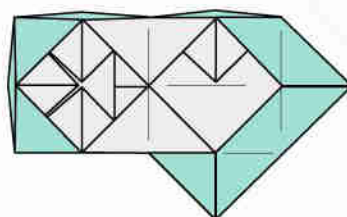

MODULO "B9" ultimato
con 2 ganci e 4 tasche

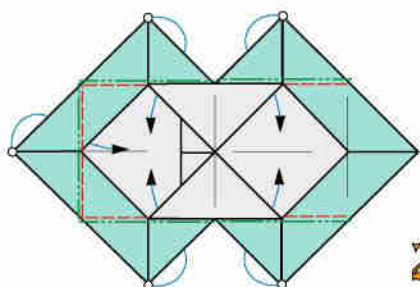

28

Modulo B.
Eseguite 5 pieghe rovesce interne

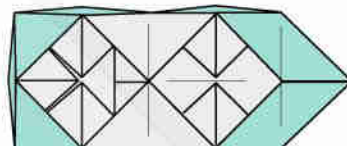

MODULO "B10" ultimato
con 1 gancio e 5 tasche

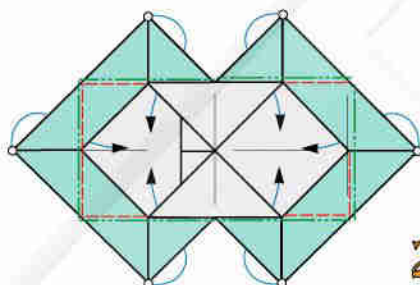

29

Modulo B.
Eseguite 6 pieghe rovesce interne

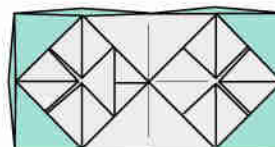

MODULO "B11" ultimato
con 6 tasche

UNIONE DI 6 MODULI B7

Si uniscono e si bloccano 3 moduli a nastro nel solito modo

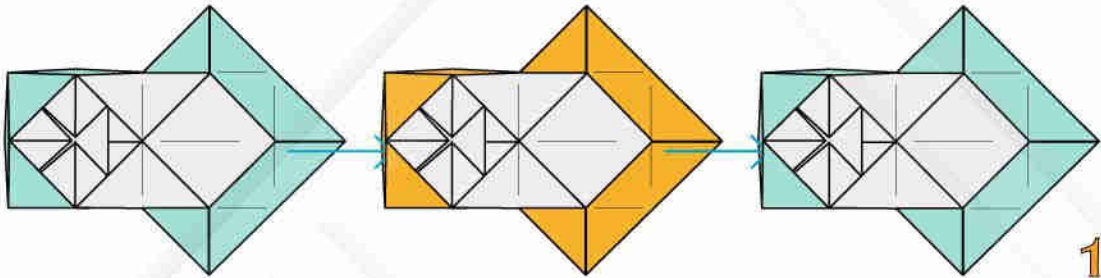

Si uniscono e si bloccano 2 nastri nel solito modo

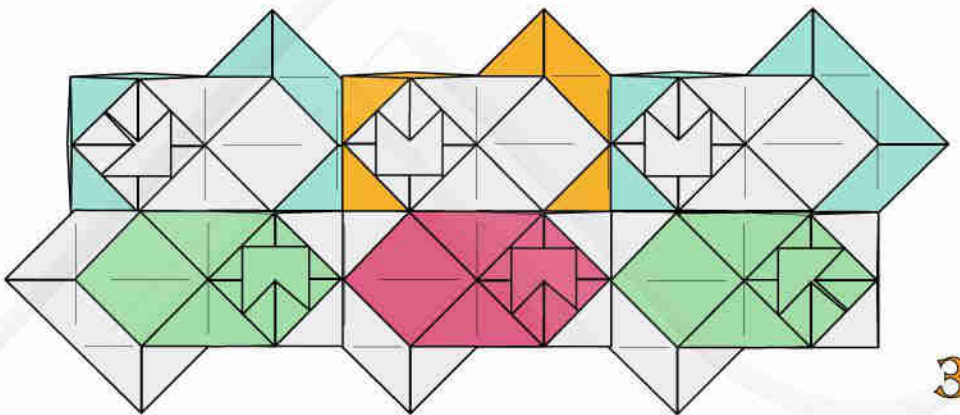
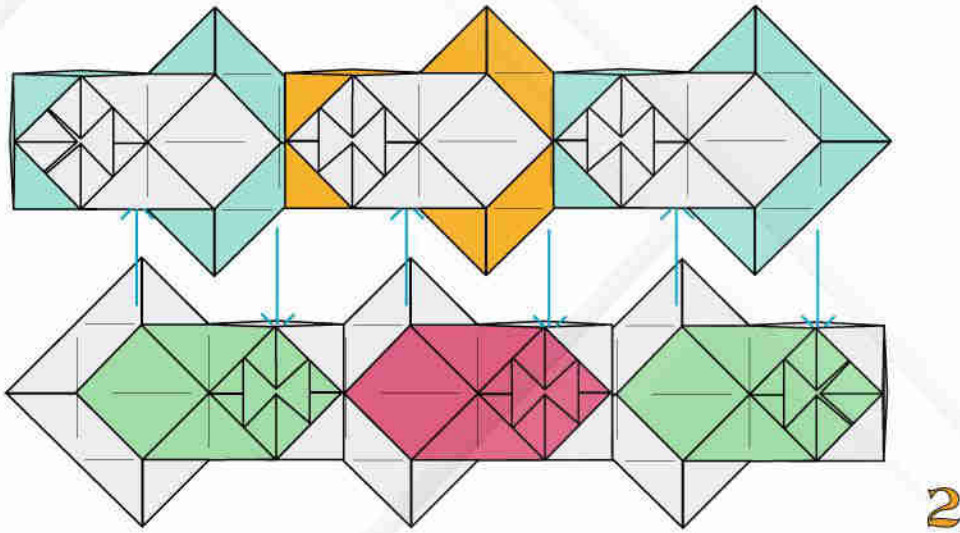

UNIONE DI 6 MODULI B7 E 2 MEZZI MODULI

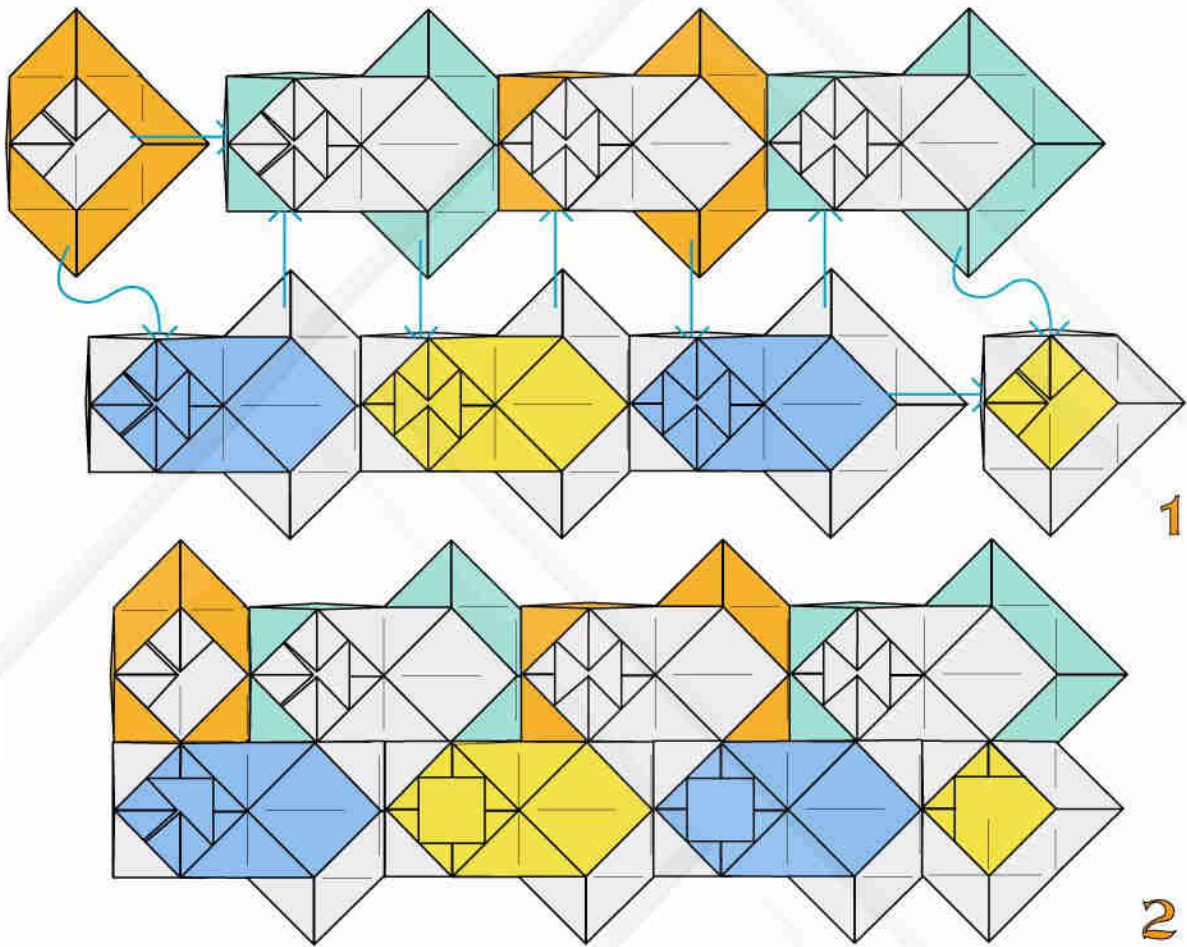

UNIONE DI 16 MODULI B7 E 4 MEZZI MODULI

Si costruisce una girandola di 4 moduli B7 con al centro in mezzo modulo

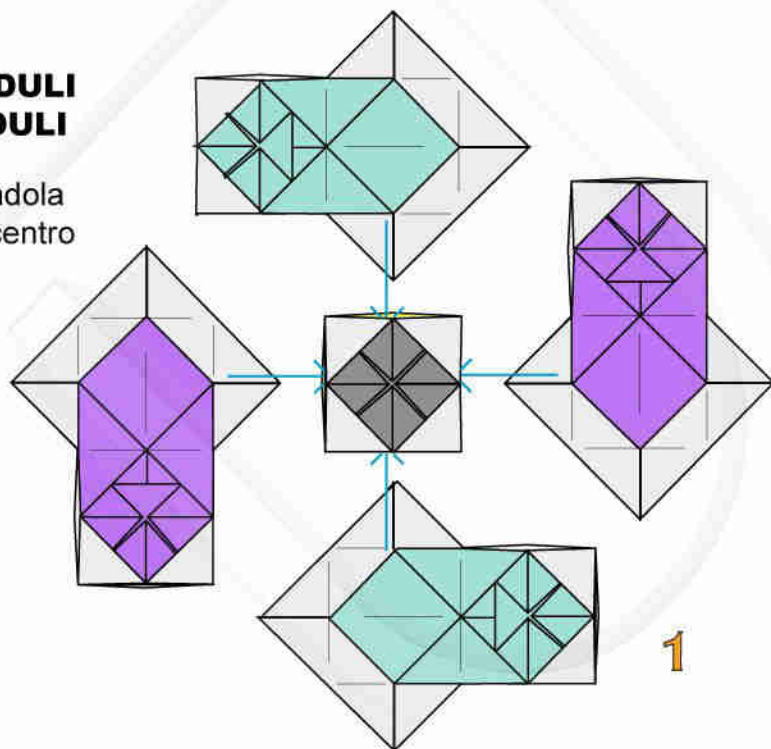

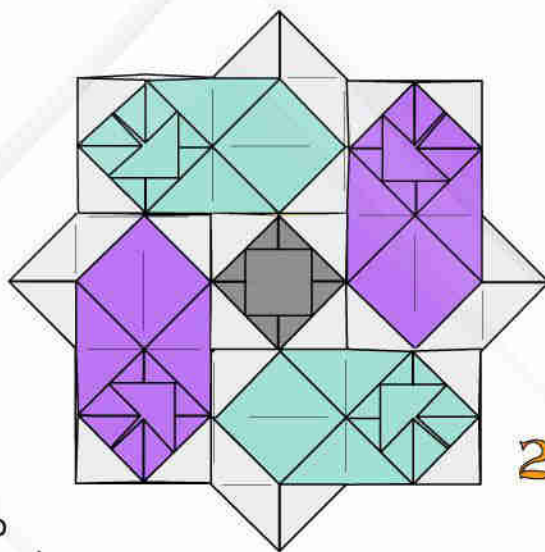

Si uniscono e bloccano
4 girandole nel solito modo

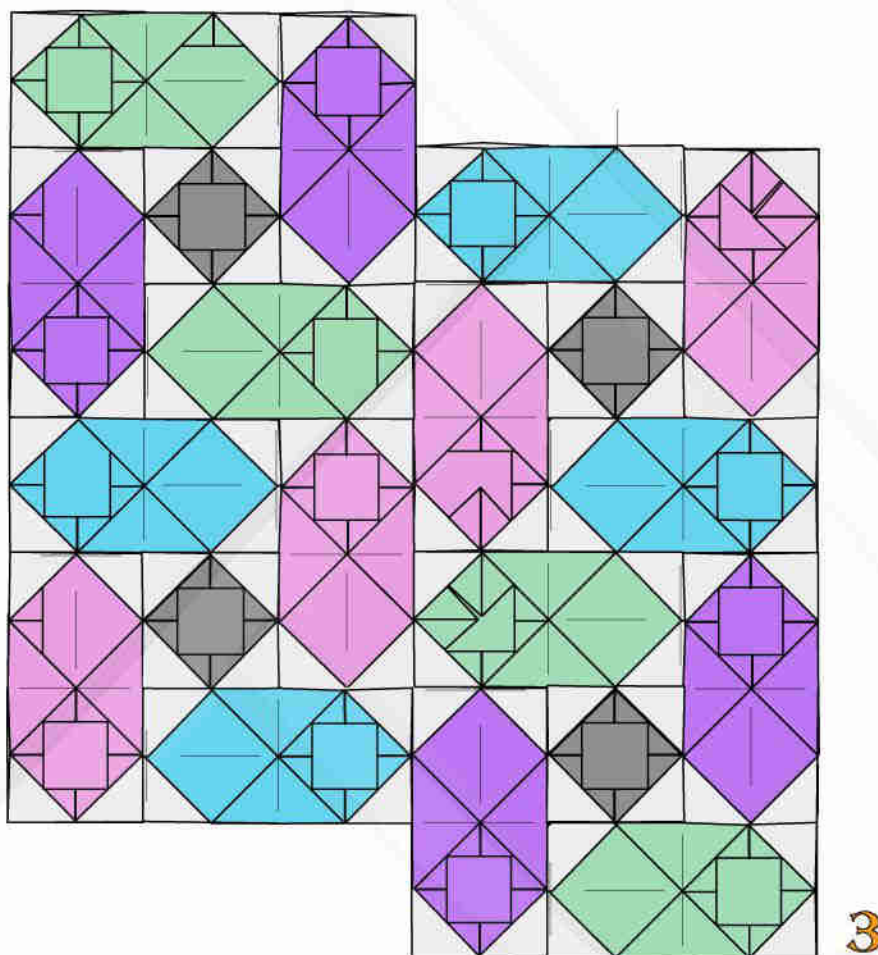

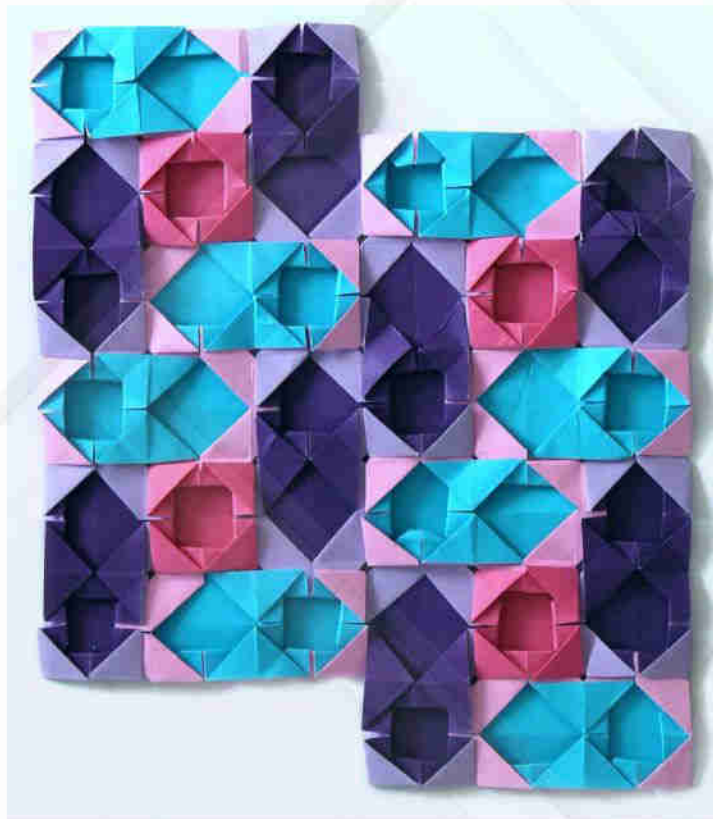

**ESEMPIO DI TASSELLAZIONE ESEGUITA
CON 16 MODULI "B7" E 4 MEZZI MODULI**

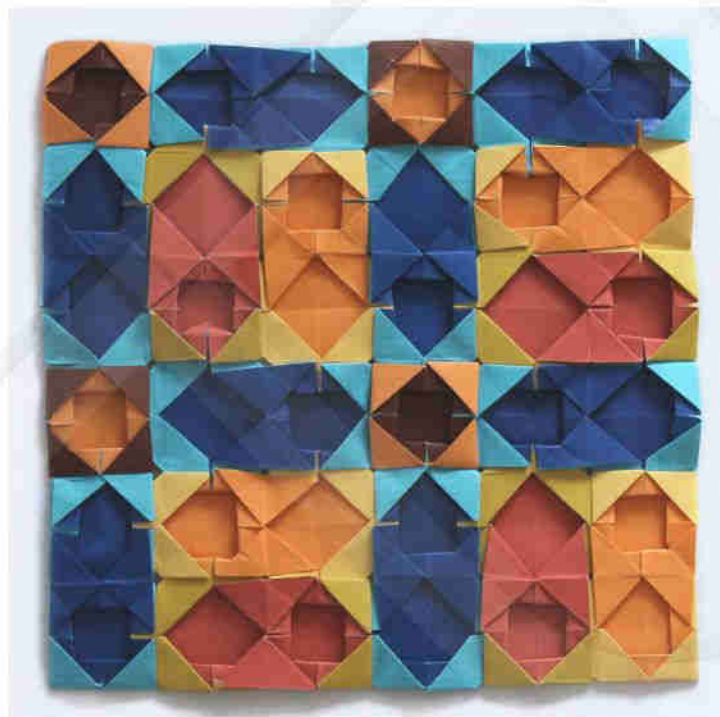



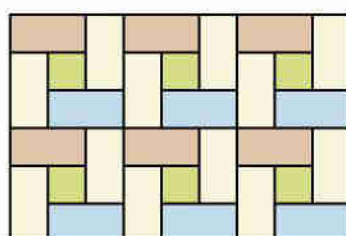
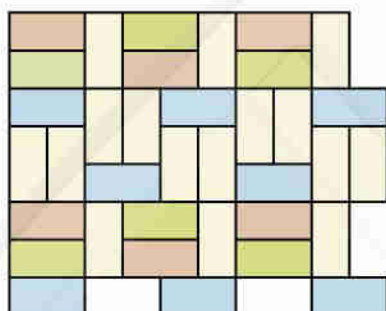
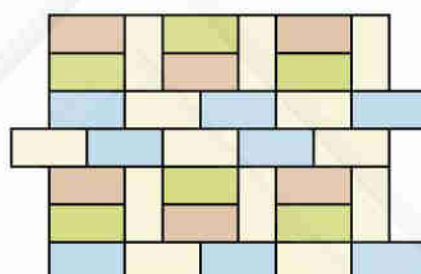
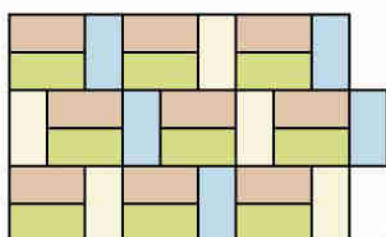
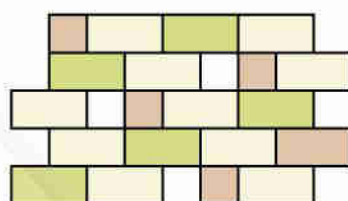
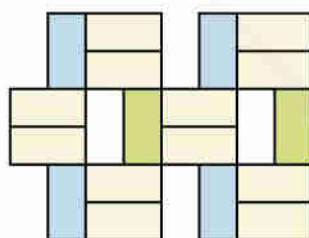
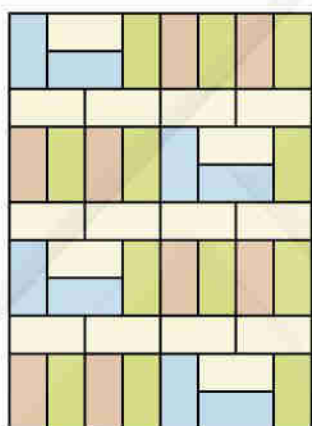

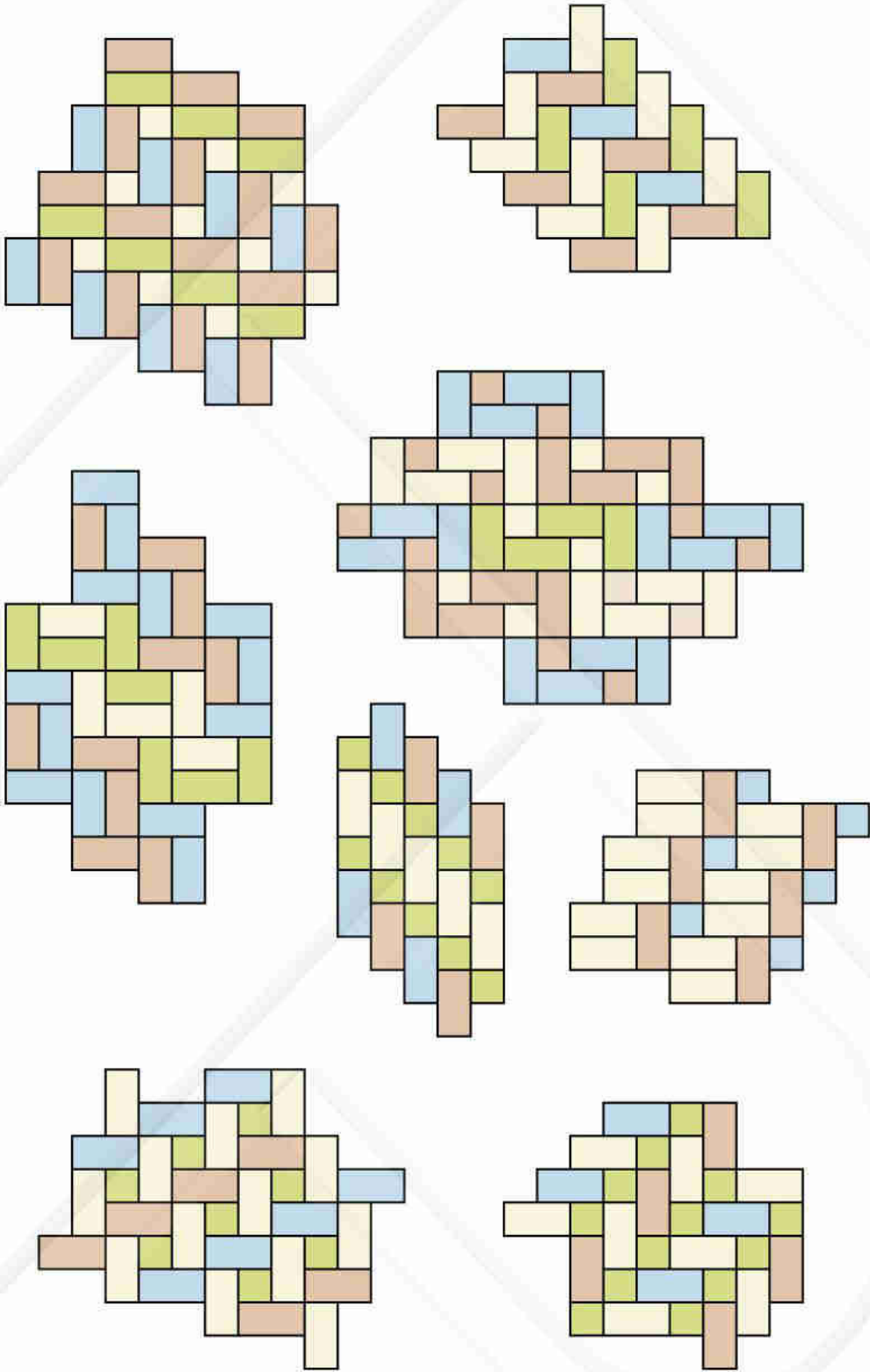





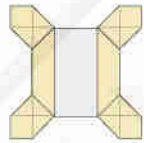

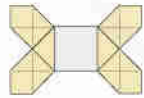
Esempi di tassellazioni realizzabili con i moduli rettangolari

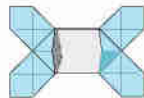
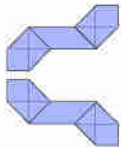
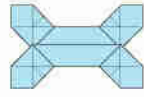
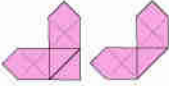
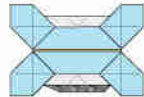
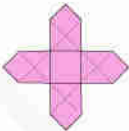
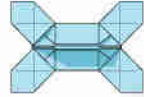

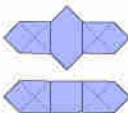

MECCANORIGAMI

CLASSIFICAZIONE TIPOLOGICA

PIASTRA		80	ASTA 2/5		116
SEMIPIASTRA		88	ASTA a C		119
SEMIPIASTRA 3D 1		94	ASTA a S		121
SEMIPIASTRA 3D 2		96	GOMITO 90°		125
SEMIPIASTRA 3D 3		99	GOMITO a croce		127
SEMIPIASTRA 3D 4		104	GOMITO a T		128
ASTA		109	GOMITO 45°		131
ASTA 4/5		112	GOMITO 135°		132
ASTA 3/5		114	GOMITO 180°		135

Piastra

Principale elemento di Meccanorigami, base di molte realizzazioni 2D e 3D.
Di semplice costruzione. Adoperate carta quadrata robusta, monocoloro o bicolore.

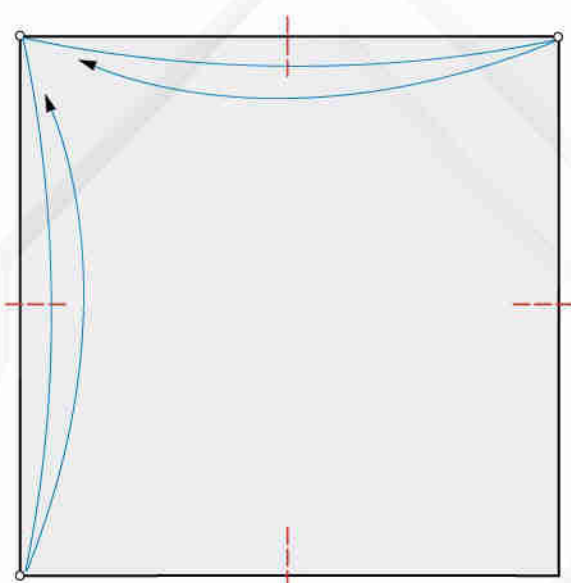

1

4 piccole pieghe a valle

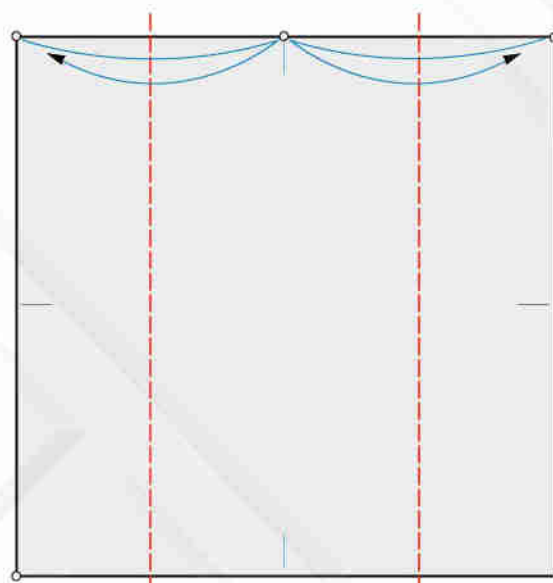

2

2 pieghe a valle

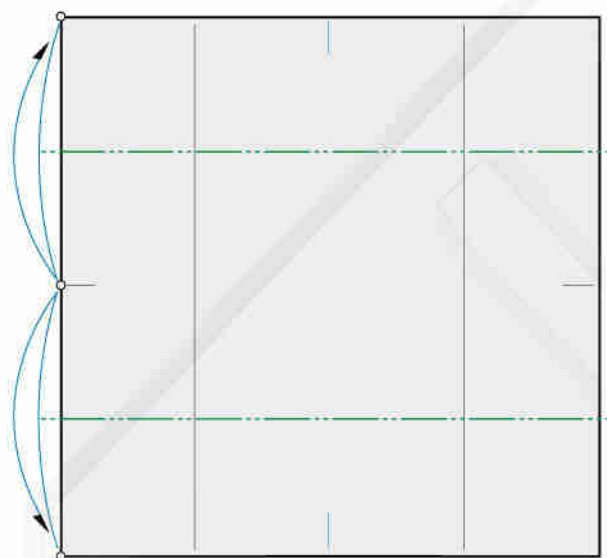

3

2 pieghe a monte

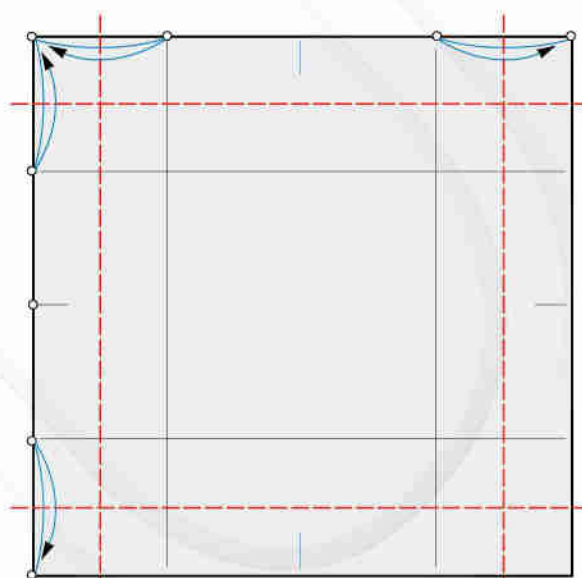

4

4 pieghe a valle

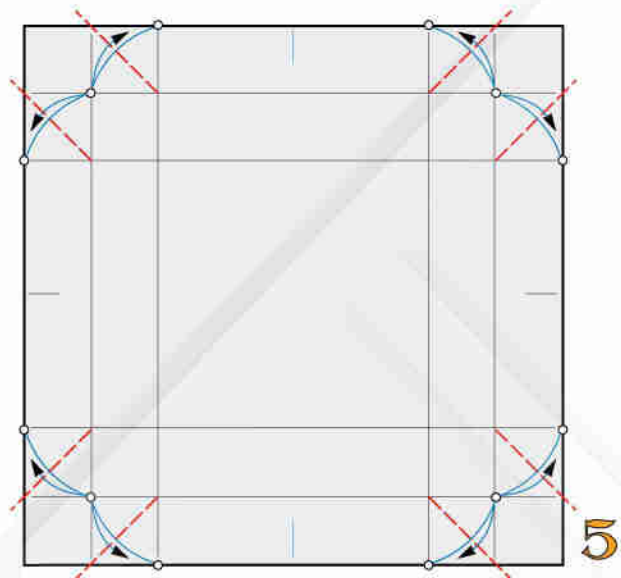

8 pieghe a valle

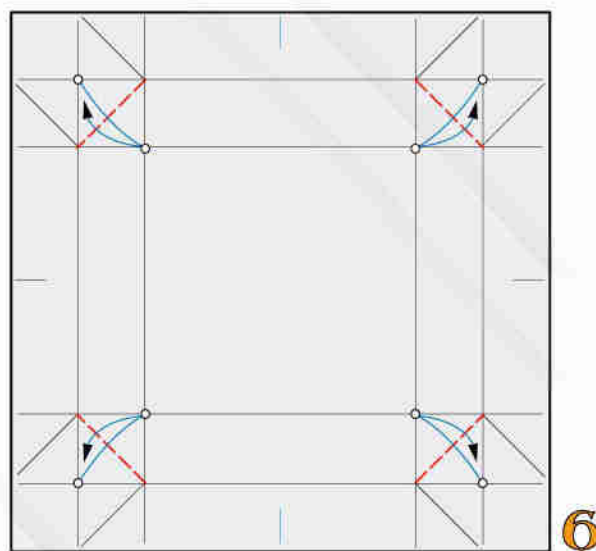

4 pieghe a valle

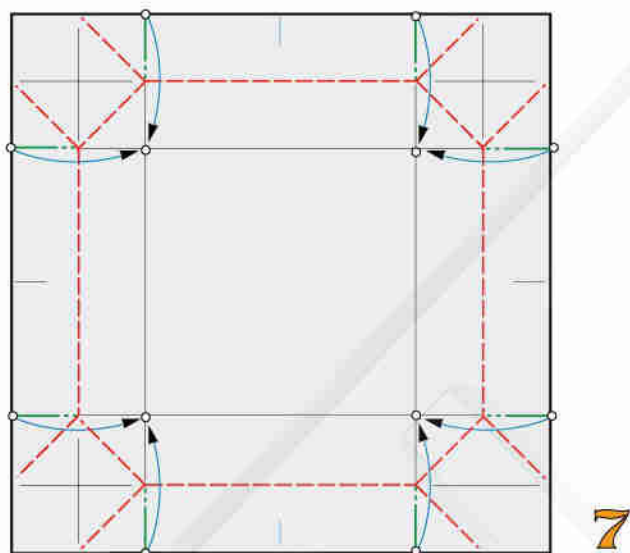

Ruotate ripiegando a valle ed a monte. Non è un passaggio difficile, nonostante le apparenze. Non eseguite subito le 4 pieghe diagonali a valle, queste risultano quasi automaticamente piegandone una alla volta dopo aver ruotato i 2 bordi concorrenti

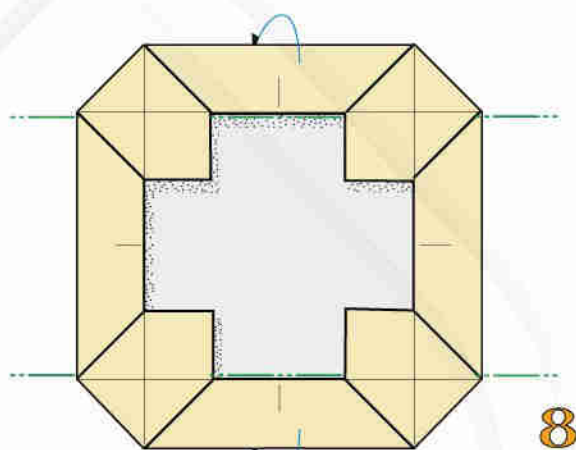

Ruotate ripiegando 2 volte a monte

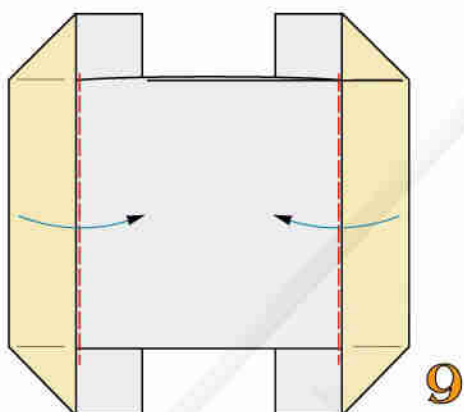

Ruotate ripiegando 2 volte a valle

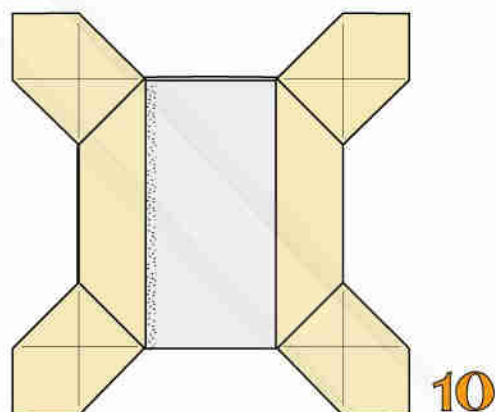

Modulo tipo "A" ultimato

A questo punto bisogna scegliere quali appendici trasformare per l'aggancio, perchè ciò implica una differente resa di colore quando i moduli sono di tinta differente. Dobbiamo ridurre la superficie delle appendici da inserire entro quelle dell'altro modulo. In questo caso si sono scelte quella a destra in alto e quella a sinistra in basso

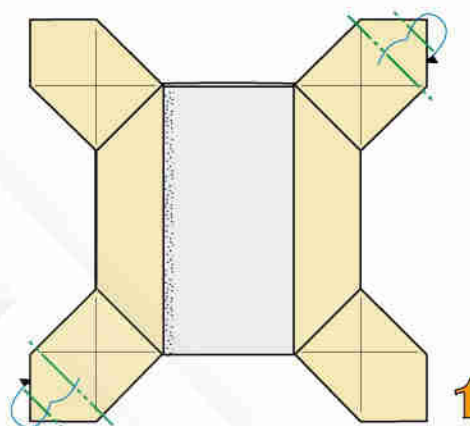

4 pieghe a monte e ruotate in successione

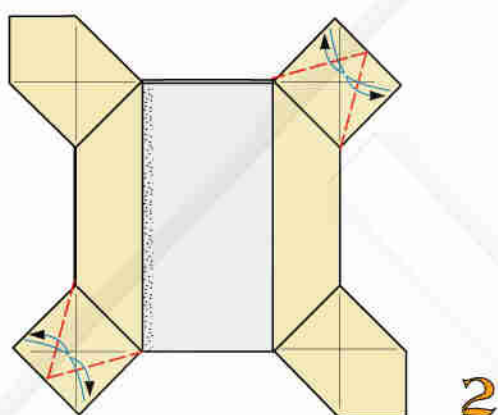

4 pieghe a valle

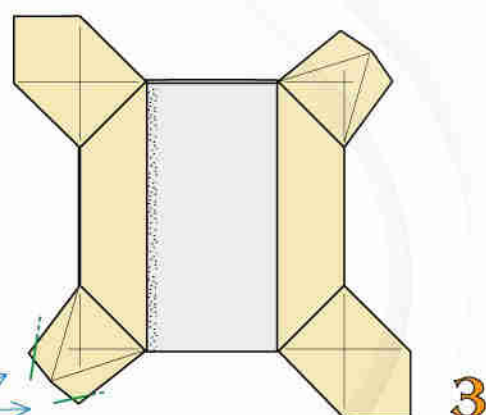

Modulo tipo "A" pronto per essere agganciato. Se ci sono difficoltà a far entrare le appendici, ridurre il bordo d'ingresso con 1 o 2 pieghe sugli angoli

UNIONE DI 2 PIASTRE

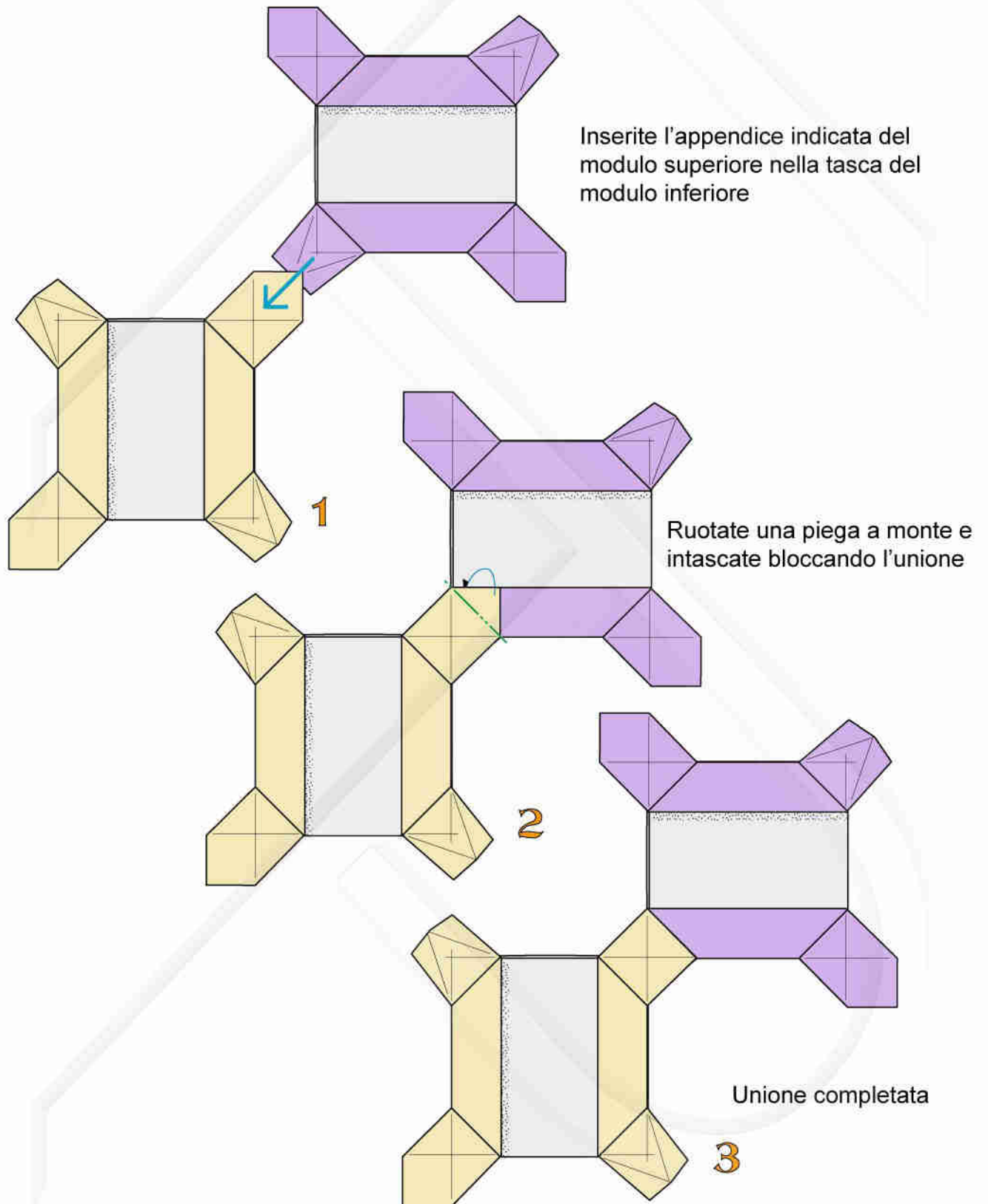

ESEMPIO DI TASSELLAZIONE REALIZZATA UNENDO 12 PIASTRE

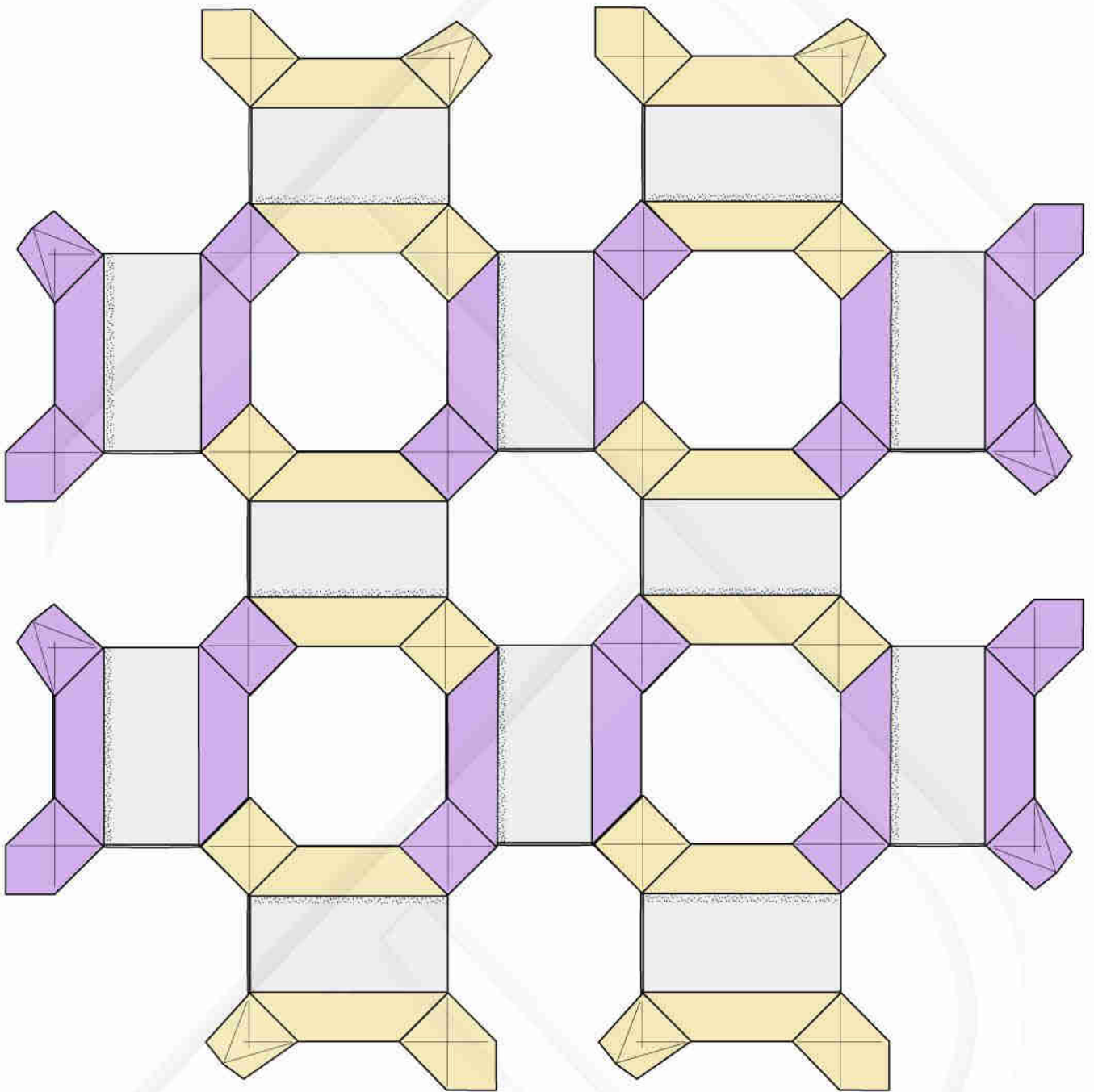

ESEMPIO DI TASSELLAZIONE REALIZZATA INTRECCIANDO 16 PIASTRE

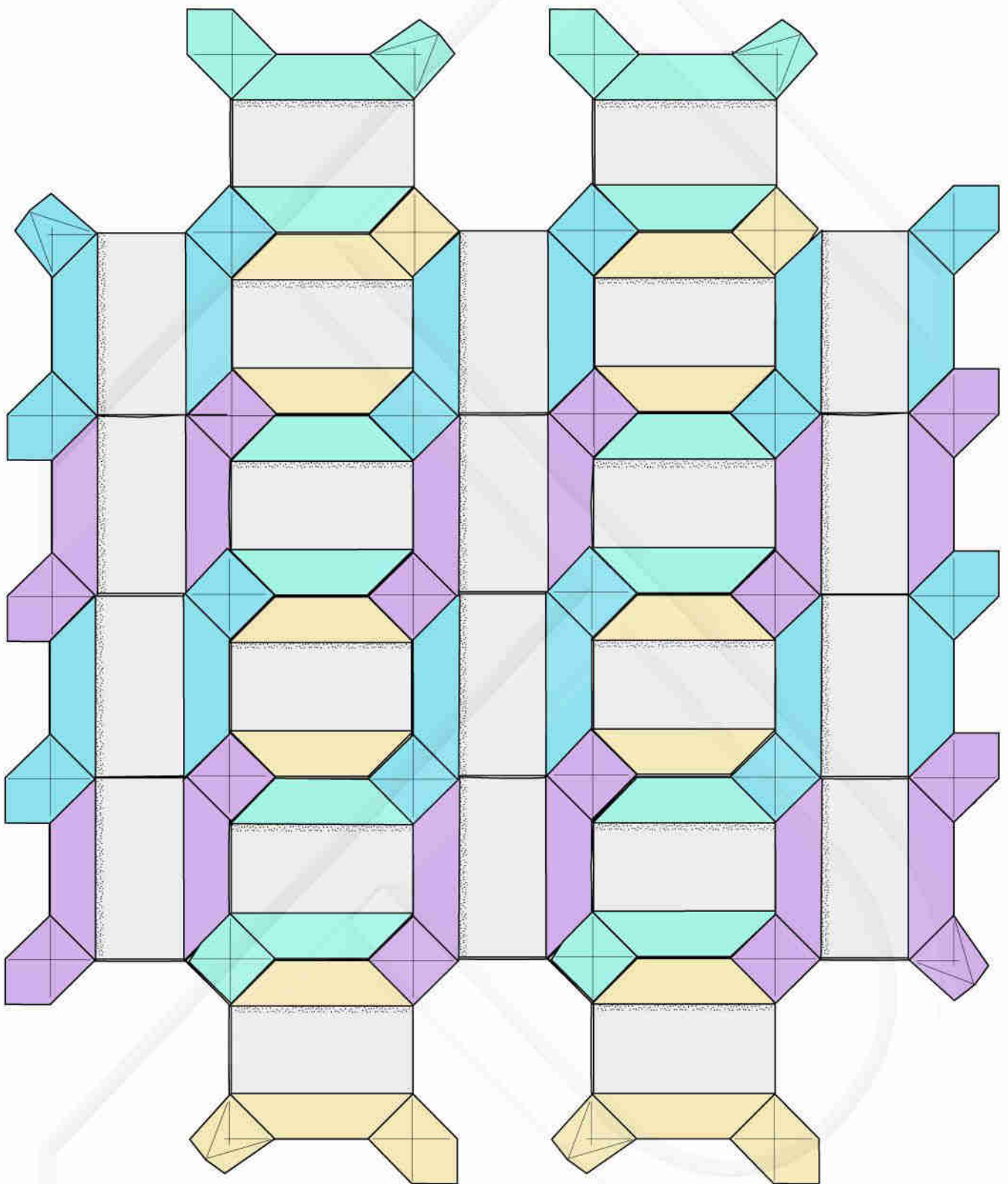

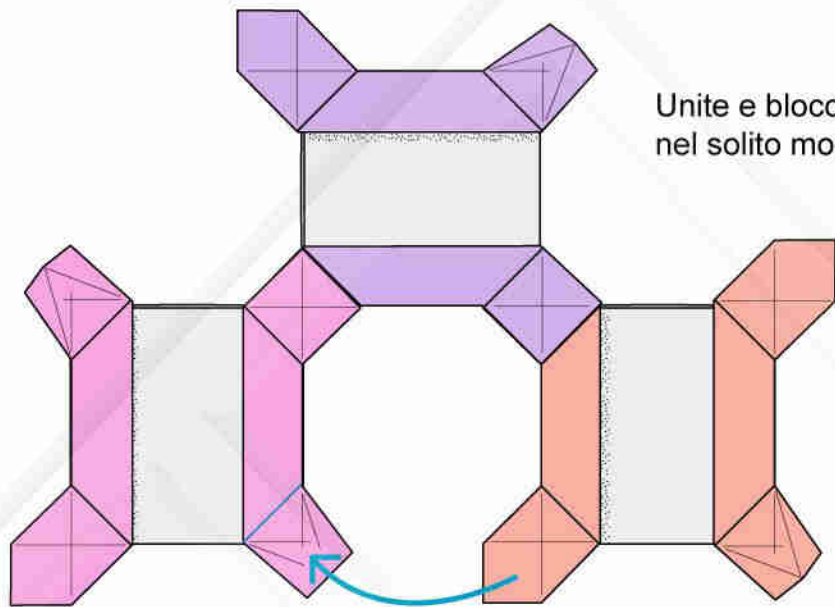

Unite e bloccate 3 moduli nel solito modo

UNENDO 3 MODULI SI REALIZZA UNA TASSELLAZIONE IN RILIEVO, AVENTE I MODULI INCLINATI FRA LORO DI 60 GRADI E SPAZI VUOTI A FORMA DI TRIANGOLO EQUILATERO ED ESAGONO REGOLARE

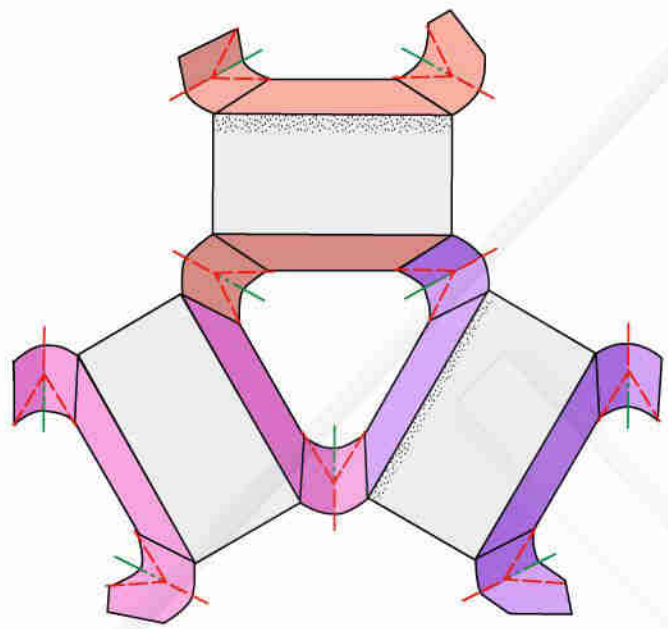

Modellate gli angoli a valle ed a monte

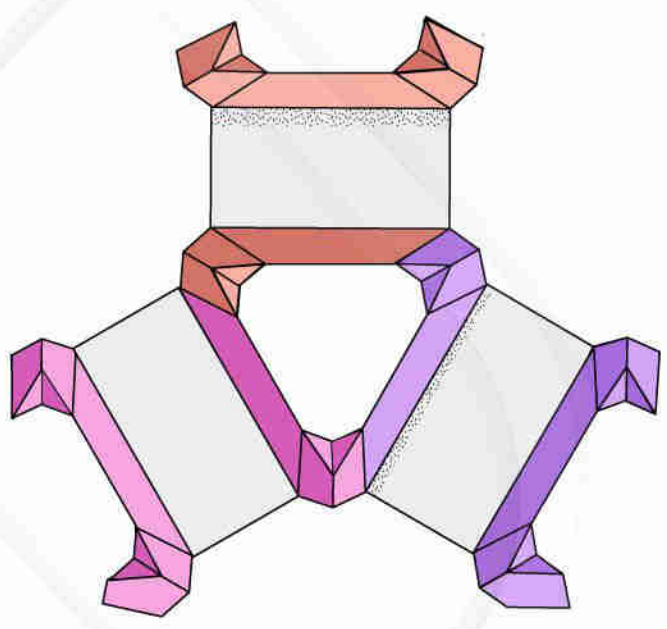

Unione completata

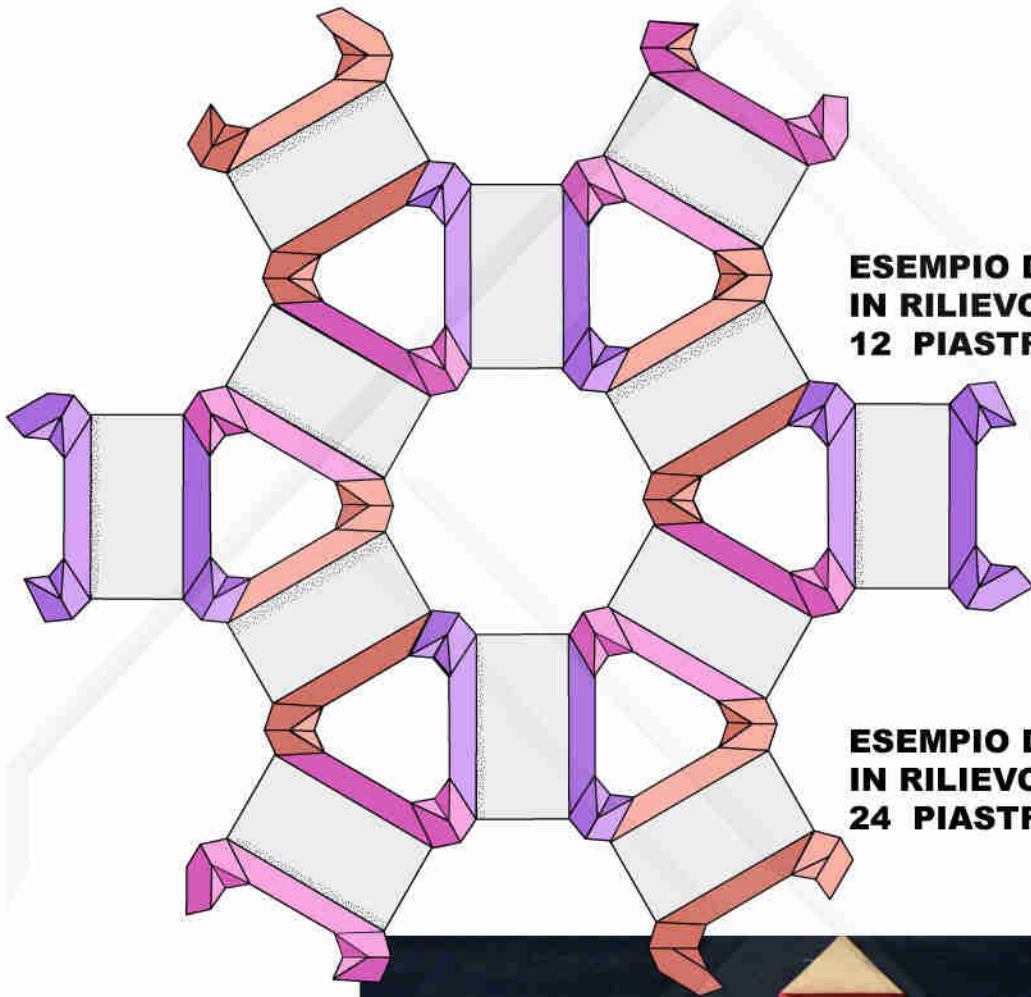

**ESEMPIO DI TASSELLAZIONE
IN RILIEVO REALIZZATA CON
12 PIASTRE**

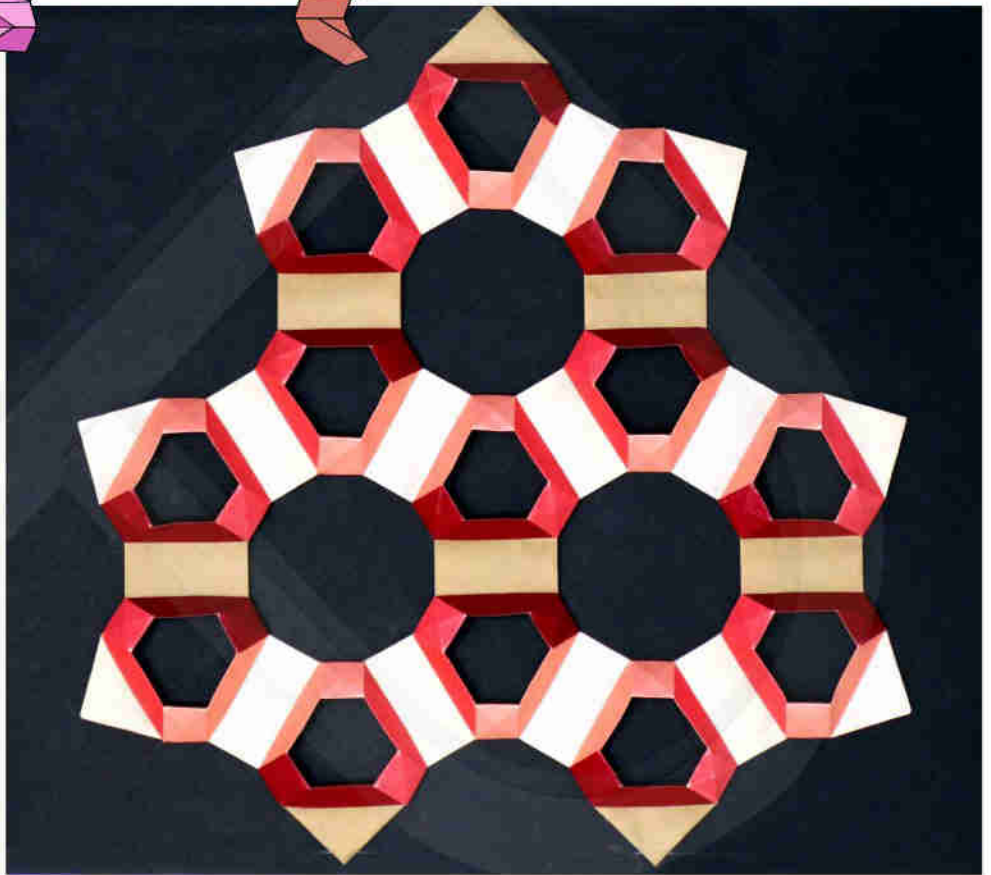

**ESEMPIO DI TASSELLAZIONE
IN RILIEVO REALIZZATA CON
24 PIASTRE**

Semipiastra

Secondo elemento base, indispensabile per la costruzione di molti modelli 2D e 3D.
Di semplice costruzione. Adoperate carta quadrata robusta, monocoloro o bicolore.

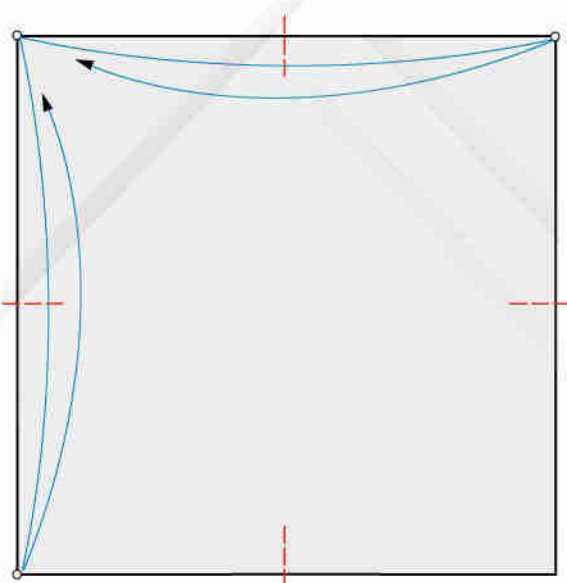

4 piccole pieghe a valle

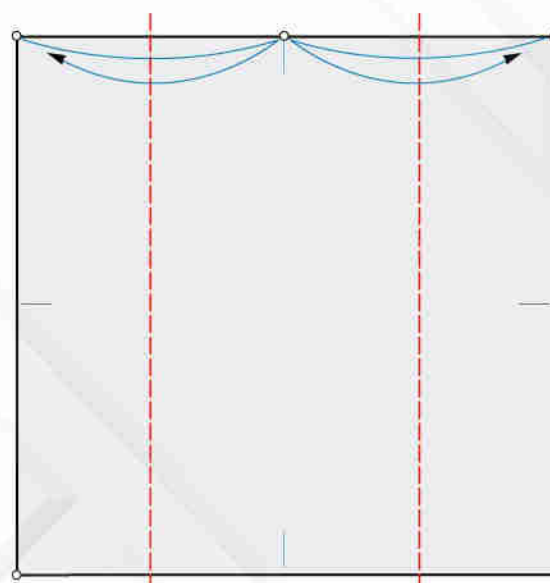

2 pieghe a valle

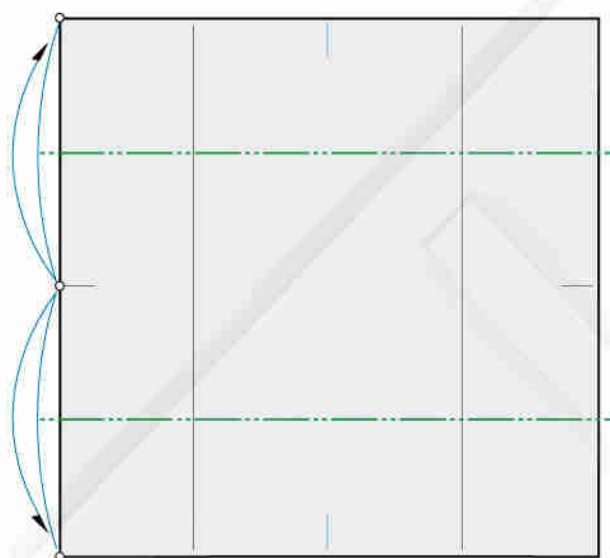

2 pieghe a monte

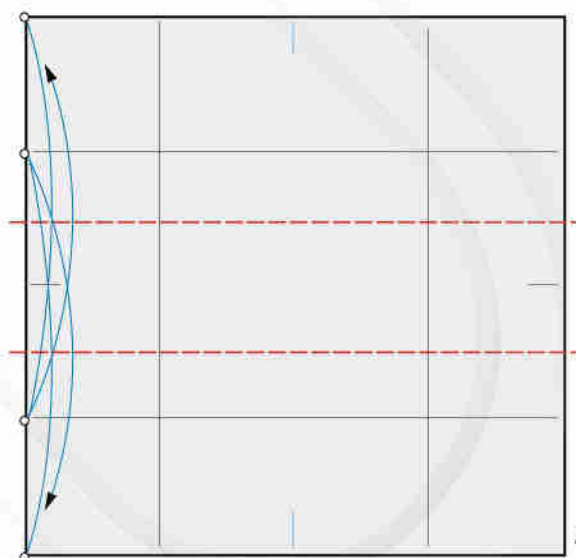

2 pieghe a valle

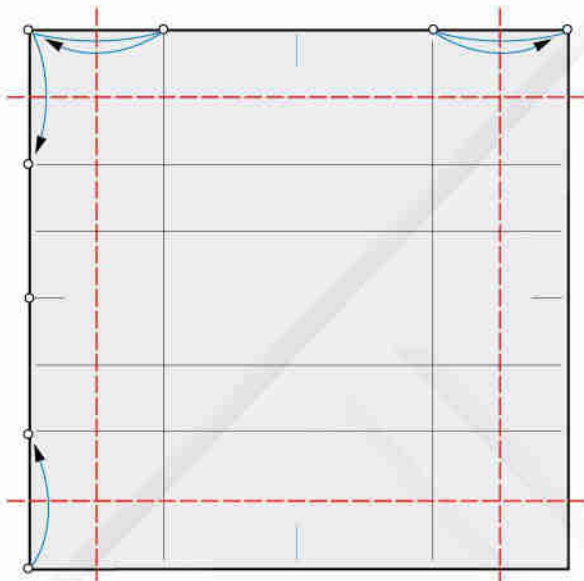

4 pieghe a valle e ruotate 2 volte

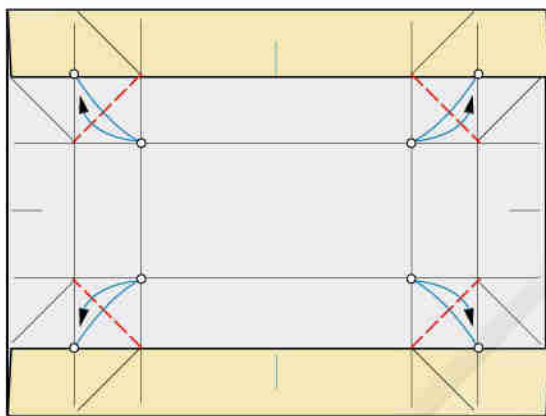

4 pieghe a valle

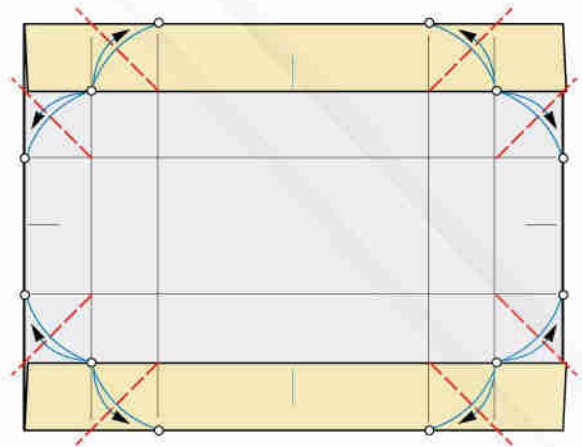

8 pieghe a valle

6

5

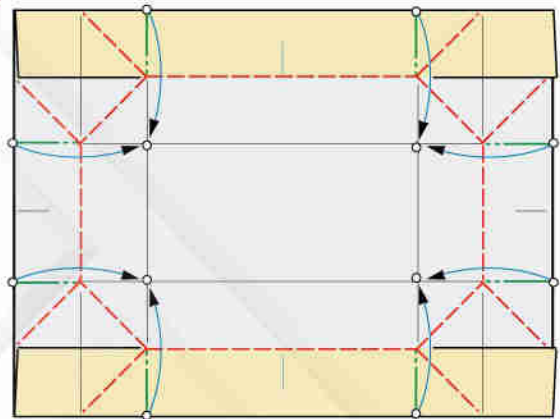

8

7

Ruotate ripiegando a valle ed a monte. Non è un passaggio difficile, nonostante le apparenze. Non eseguite subito le 4 pieghe diagonali a valle, queste risultano quasi automaticamente piegandone una alla volta dopo aver ruotato i 2 bordi concorrenti

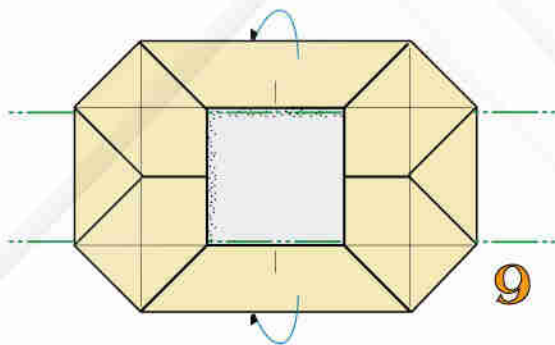

9

Ruotate ripiegando 2 volte a monte

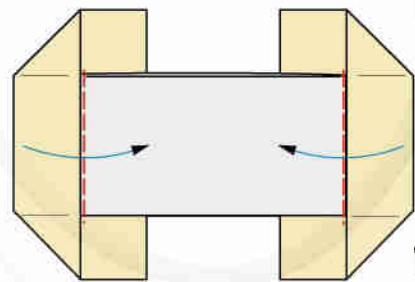

10

Ruotate ripiegando 2 volte a valle

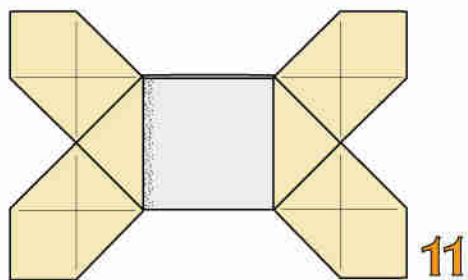

A questo punto bisogna scegliere quali appendici trasformare per l'aggancio, perchè ciò implica una differente resa di colore quando i moduli sono di tinta differente. Dobbiamo ridurre la superficie delle appendici da inserire entro quelle dell'altro modulo. In questo caso si sono scelte quella a sinistra in alto e quella a destra in basso

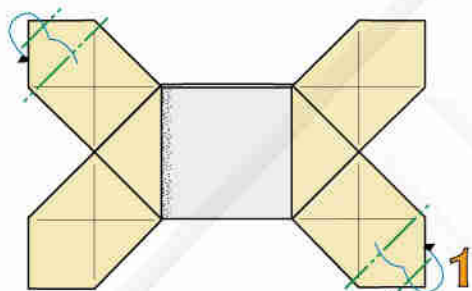

4 pieghe a monte e ruotate in successione

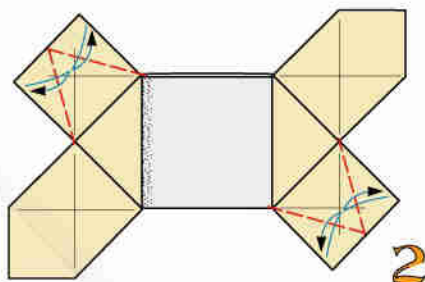

4 pieghe a monte e ruotate

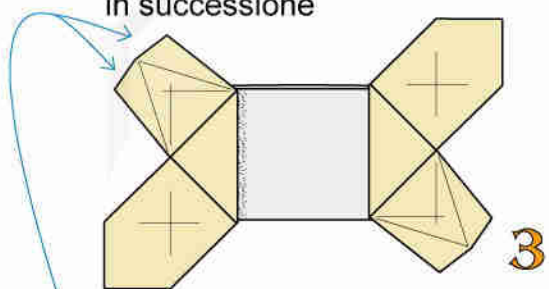

Semipiastra pronta per l'aggancio. Se ci sono difficoltà a far entrare le appendici, ridurre il bordo d'ingresso con 1 o 2 piegine sugli angoli

UNIONE DI 2 PIASTRE



Inserite l'appendice superiore nella tasca del modulo inferiore

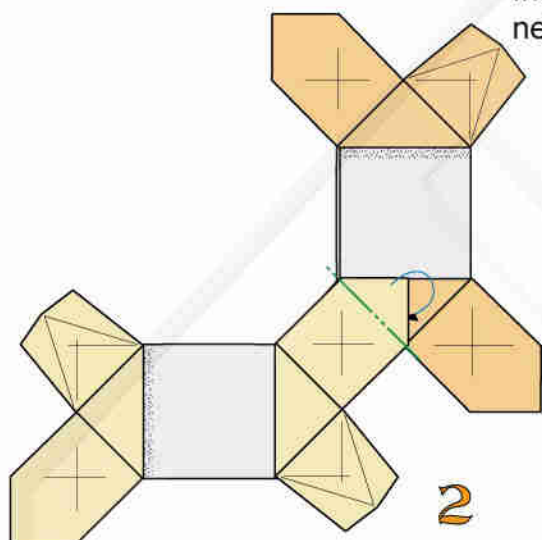

1 piega a monte ed intascate bloccando l'unione

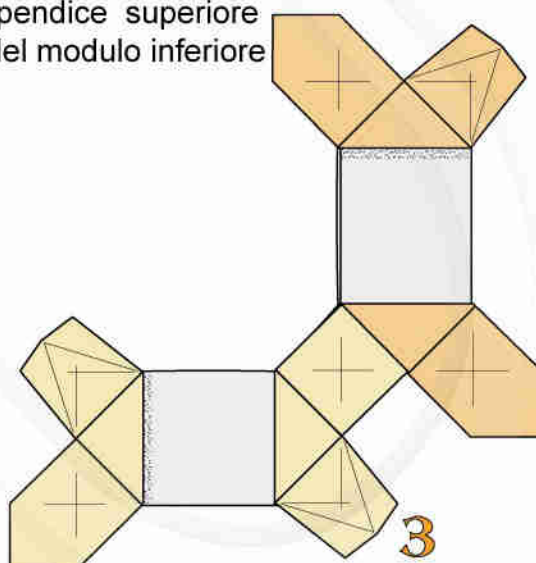

Unione completata

**ESEMPIO DI TASSELLAZIONE
REALIZZATA CON 16 SEMIPIASTRE**

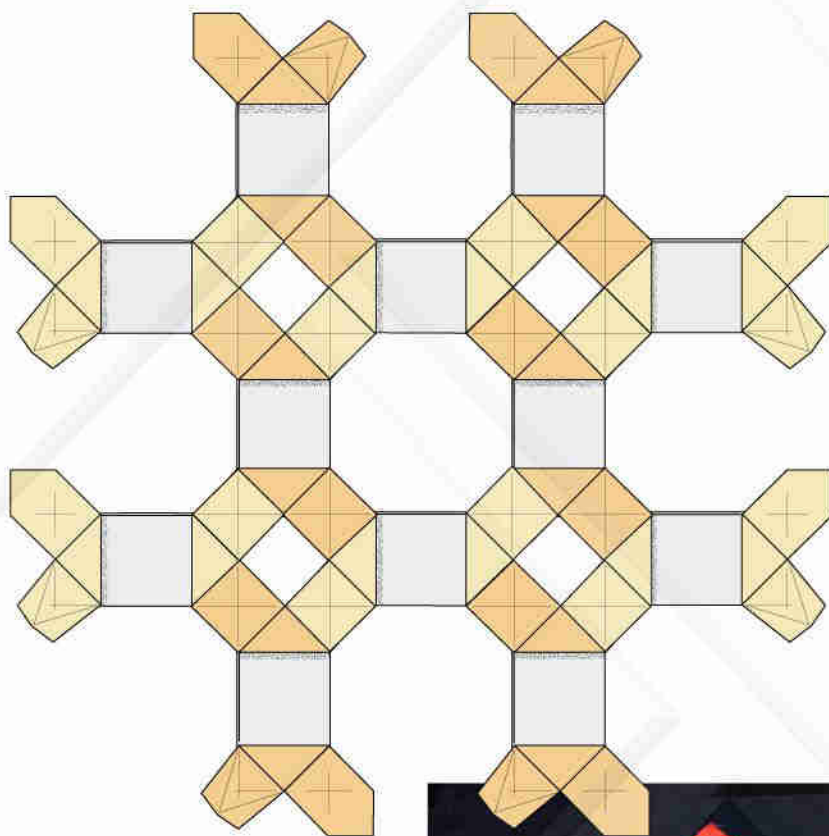

**ESEMPIO DI TASSELLAZIONE
IN RILIEVO REALIZZATA CON
SEMPIASTRE UNITE A
GRUPPI DI 3**

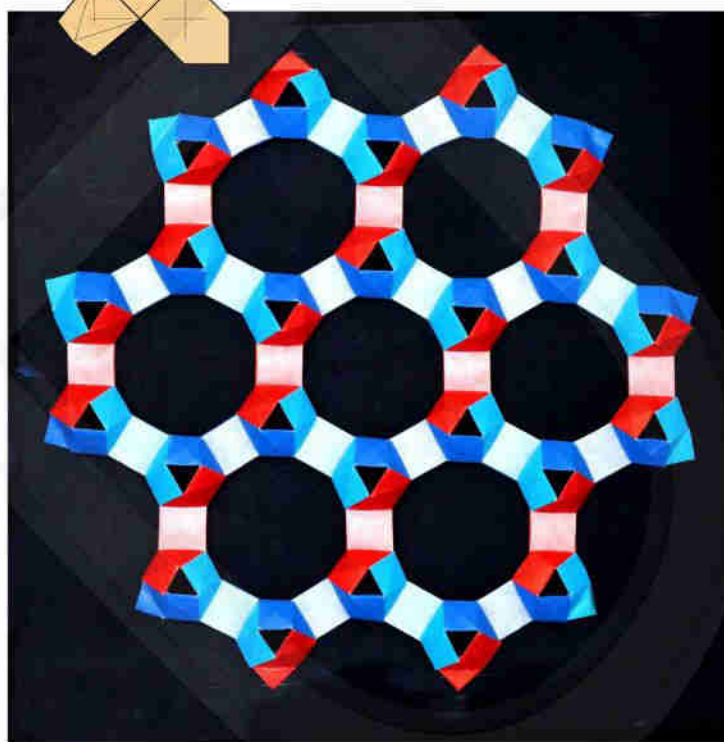

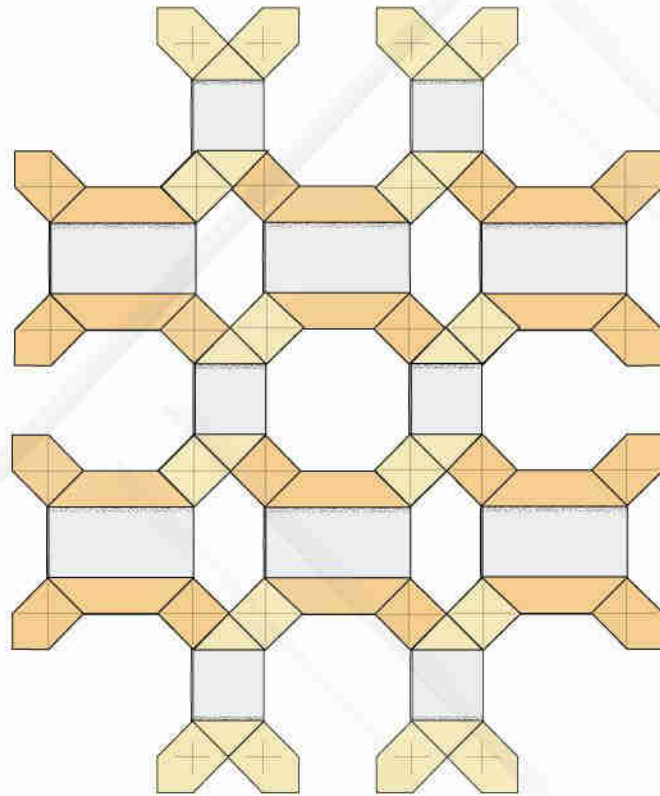

**ESEMPIO DI TASSELLAZIONE REALIZZATA
CON 6 PIASTRE E 6 SEMIPIASTRE**

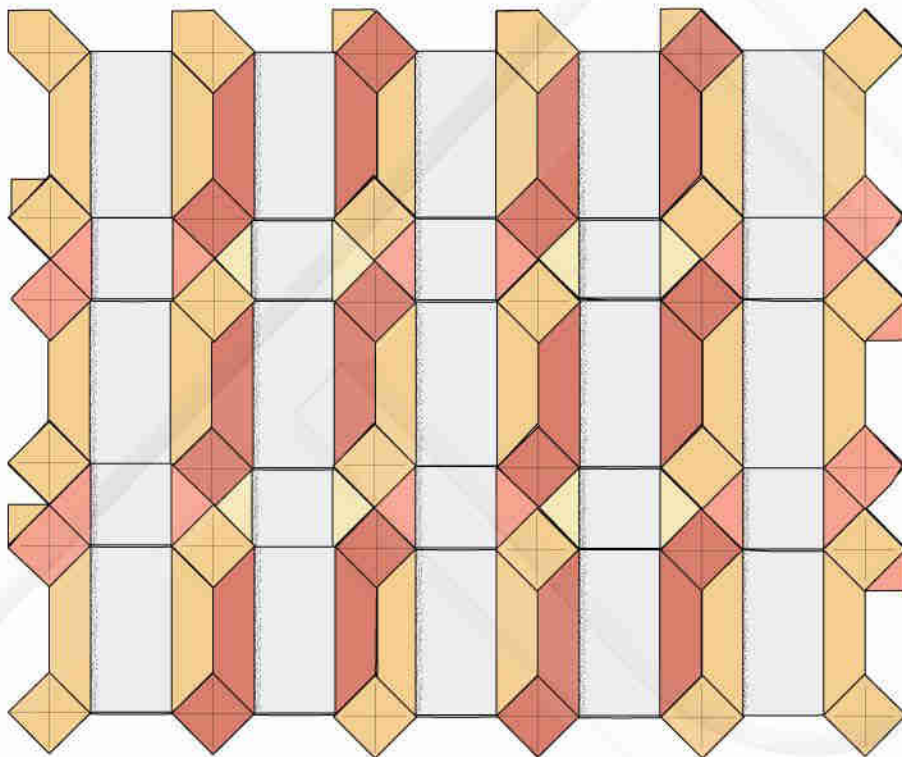

**ESEMPIO DI TASSELLAZIONE REALIZZATA
CON PIASTRE E SEMIPIASTRE INTRECCIAE**

**ESEMPIO DI TASSELLAZIONE REALIZZATA
CON PIASTRE E SEMIPIASTRE**



**ESEMPIO DI TASSELLAZIONE REALIZZATA
CON PIASTRE E SEMIPIASTRE INTRECCiate**



FRONTE



RETRO

Semipiastra 3D-1

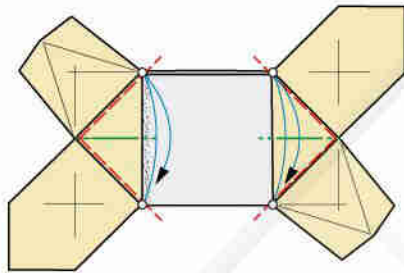

Partite dalla semipiastra.
4 pieghe a valle e 2 a monte

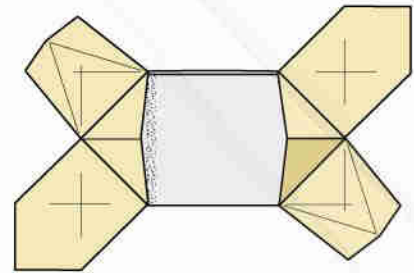

Semipiastra 3D-1 ultimata

REALIZZAZIONE DI UNA TASSELLAZIONE IN RILIEVO

Unire e bloccare 3
moduli nel solito modo

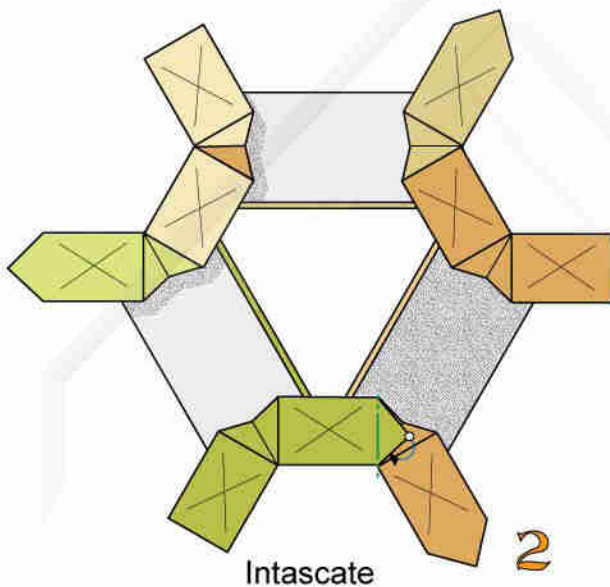
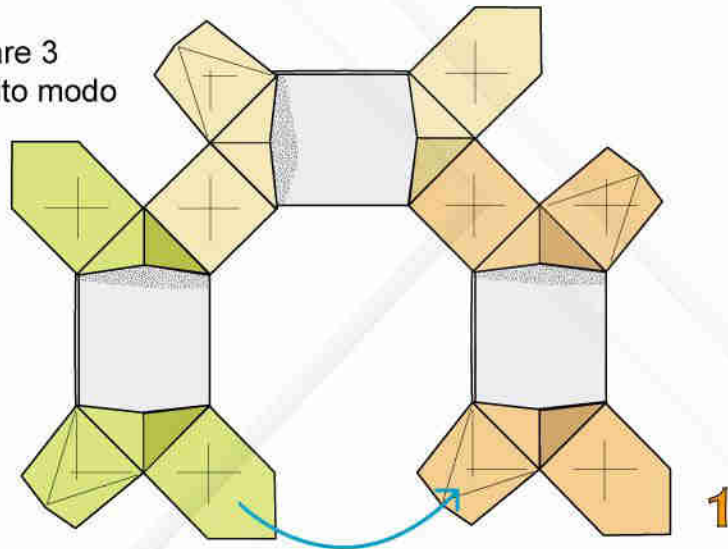

Intascate

2

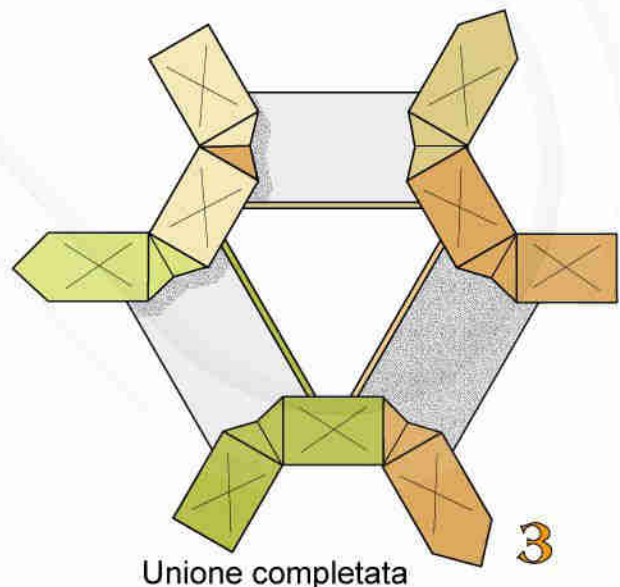

Unione completata

3

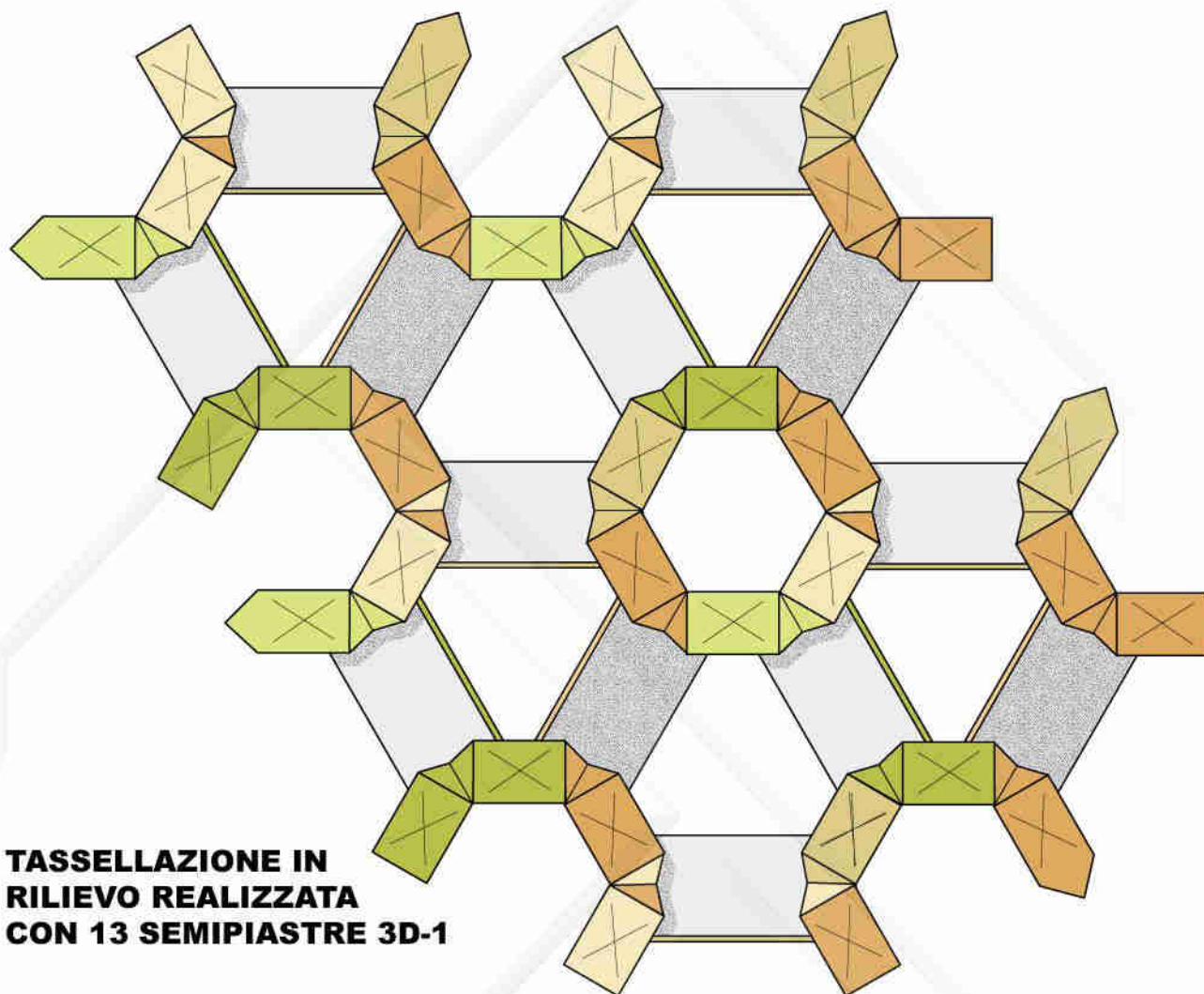

TASSELLAZIONE IN RILIEVO REALIZZATA CON 13 SEMIPIASTRE 3D-1

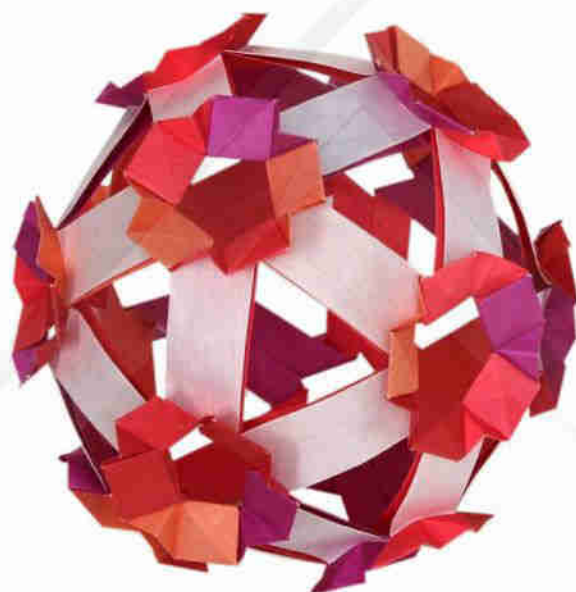

ICOSAEDRO REALIZZATO UNENDO 5 MODULI PER OGNI VERTICE. SOLIDO PLATONICO CON 20 FACCE TRIANGOLARI E 30 SPIGOLI SEMIPIASTRA "3D-1"

30 fogli carta quadrata bicolore robusta

Semipiastra 3D-2

Modulo indicato per la costruzione di poliedri

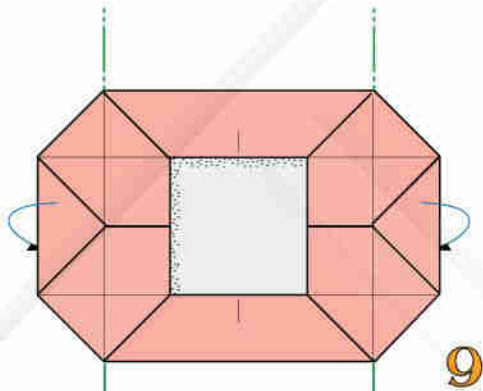

9

Partite dalla fig. n.8 di semipiastra.
Ruotate ripiegando 2 volte a monte

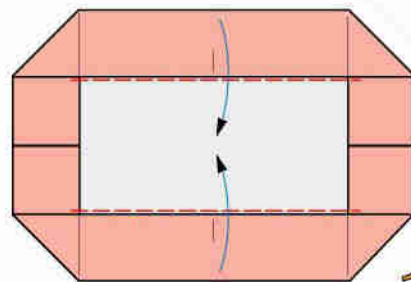

10

Ruotate ripiegando 2 volte a valle

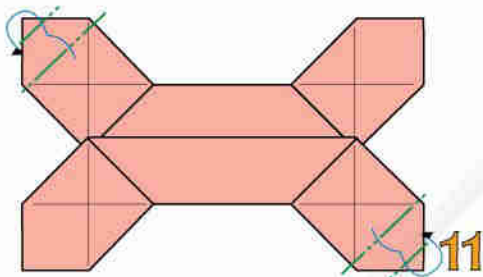

11

4 pieghe a monte e ruotate
in successione

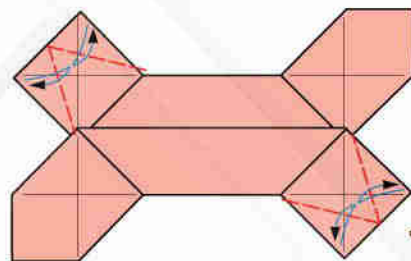

12

4 pieghe a valle e ruotate

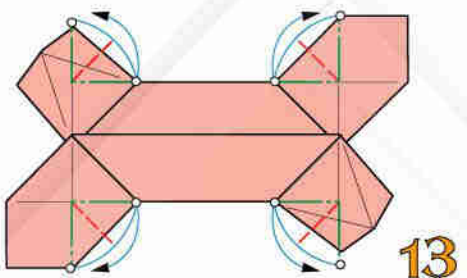

13

4 pieghe a valle e ruotate
ripiegando a monte

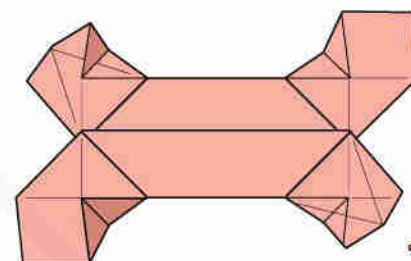

14

Semipiastra 3D-2 ultimata

REALIZZAZIONE DI UNA TASSELLAZIONE IN RILIEVO

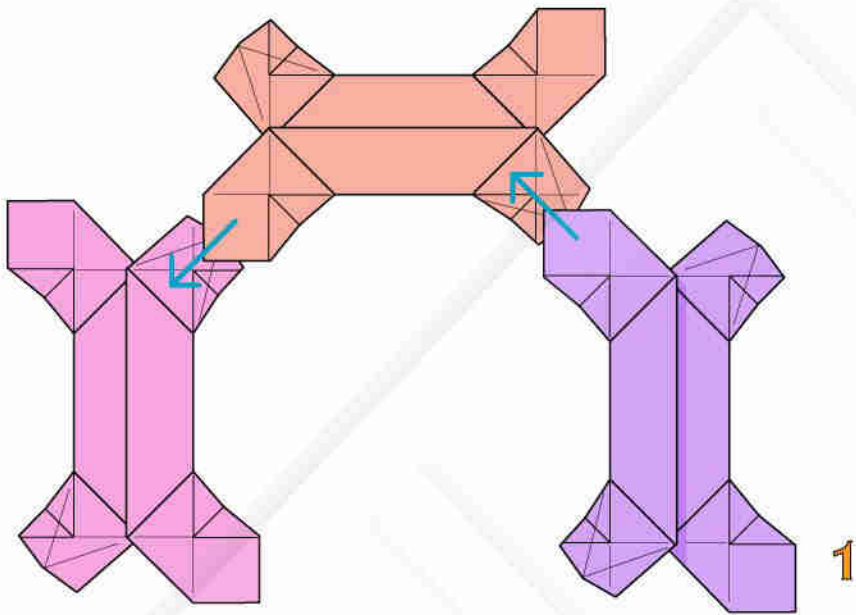

1

Unire e bloccare 3
moduli nel solito modo

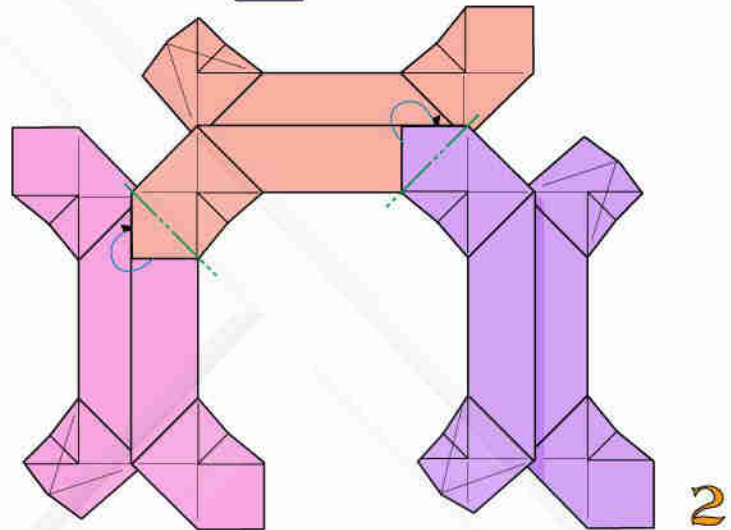

2

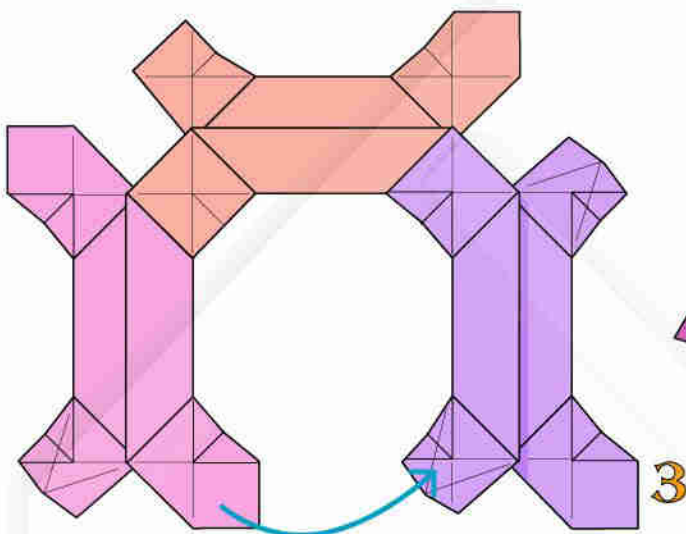

3

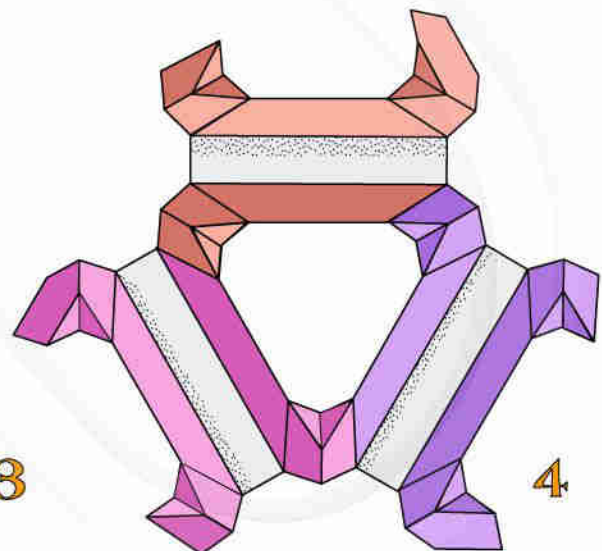

4

Unione completata

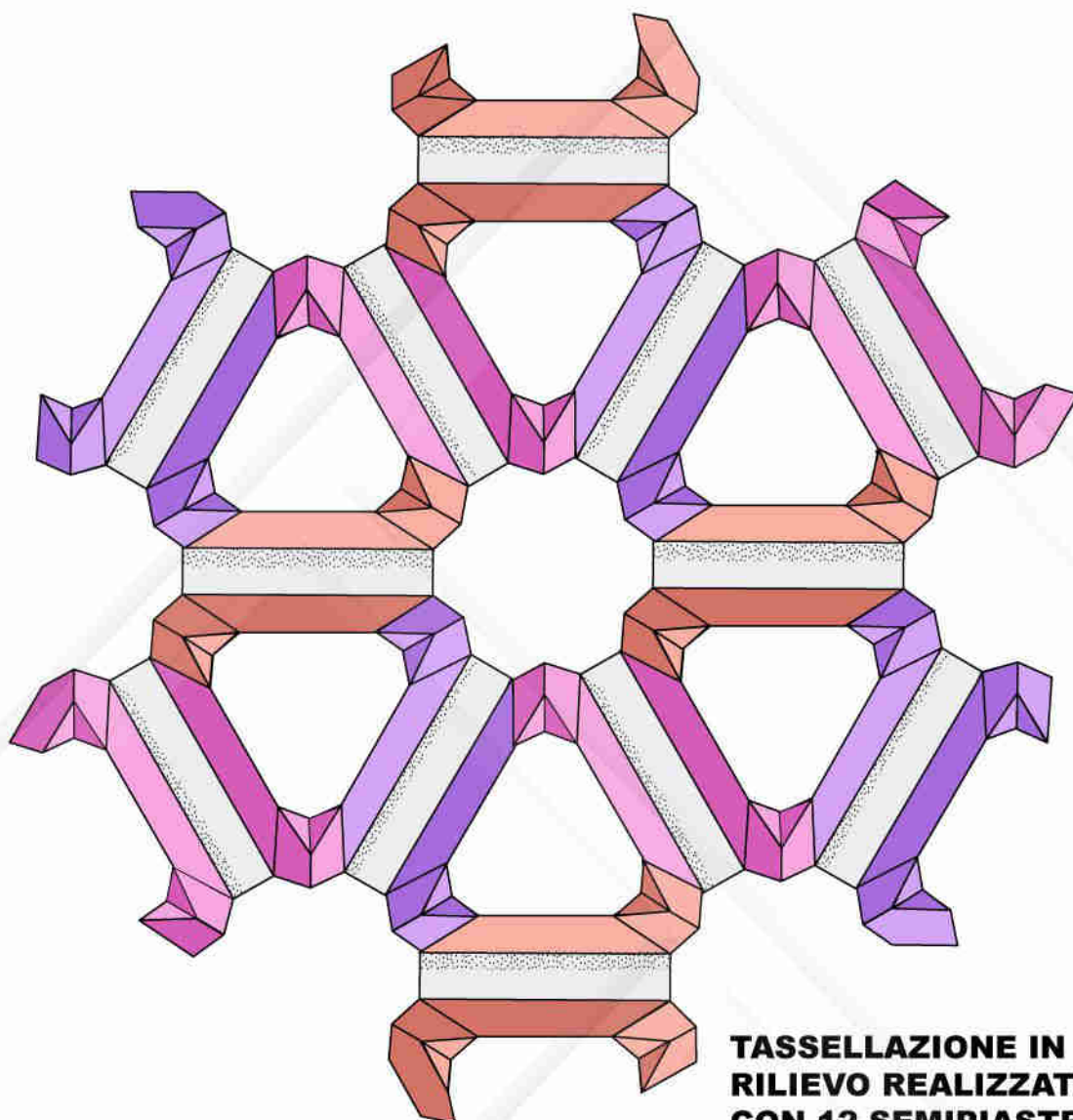

TASSELLAZIONE IN RILIEVO REALIZZATA CON 12 SEMIPIASTRE 3D-2



ICOSAEDRO REALIZZATO UNENDO 5 MODULI PER OGNI VERTICE. SOLIDO PLATONICO CON 20 FACCE TRIANGOLARI E 30 SPIGOLI SEMIPIASTRA 3D-2

30 fogli carta quadrata bicolore robusta

Semipiastra 3D-3

Modulo laborioso indicato per la realizzazione di tassellazioni in rilievo e poliedri

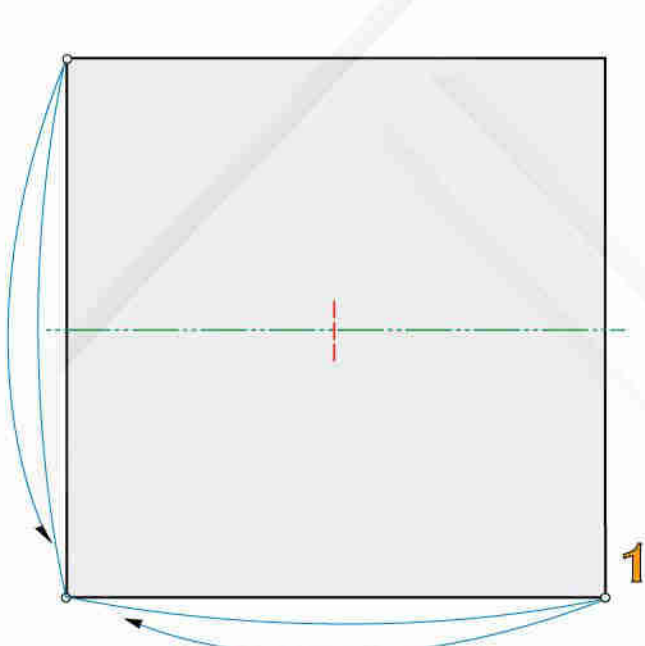

1 piccola piega a valle ed 1 a monte

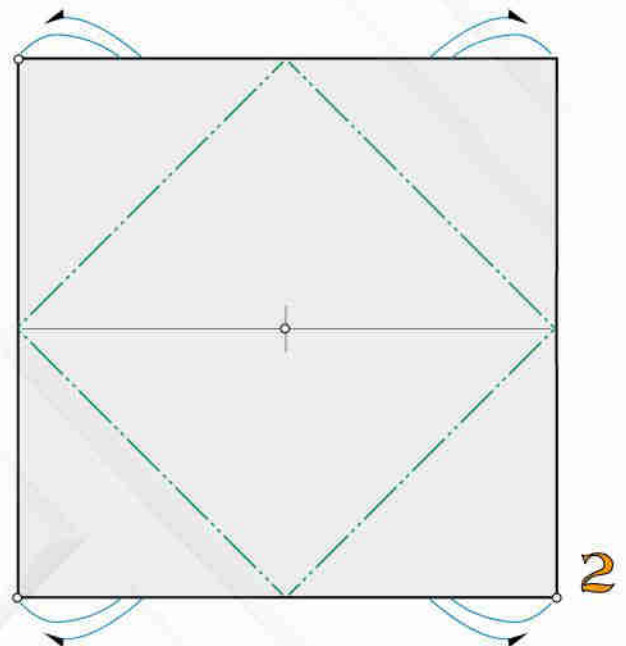

4 pieghe a monte

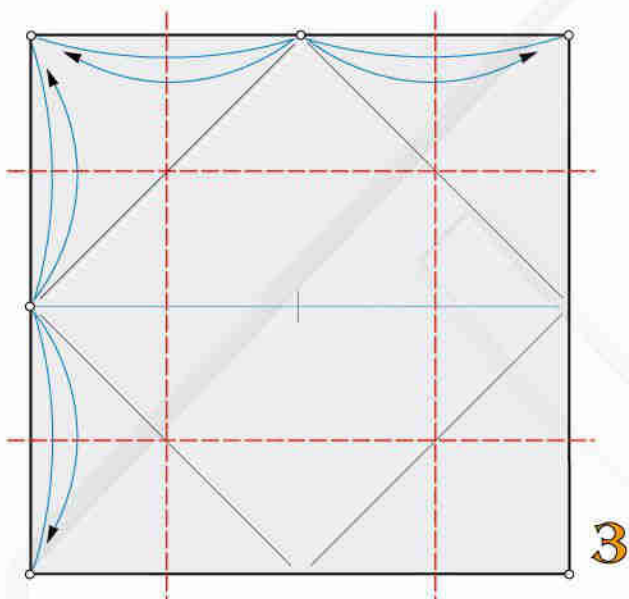

4 pieghe a valle

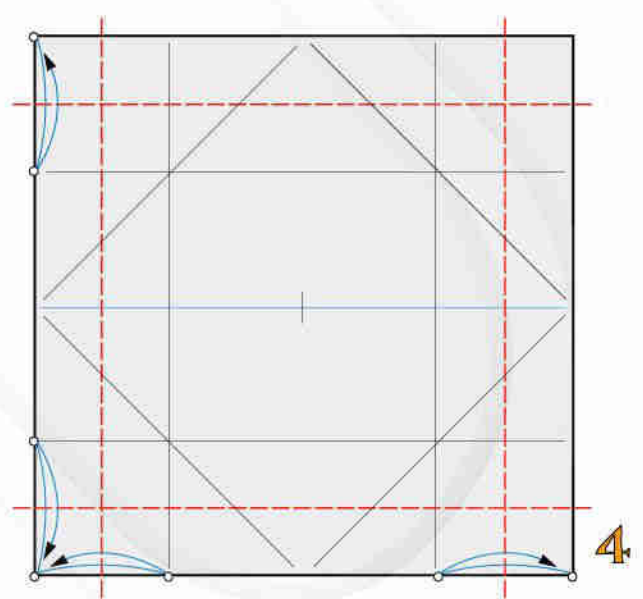

4 pieghe a valle

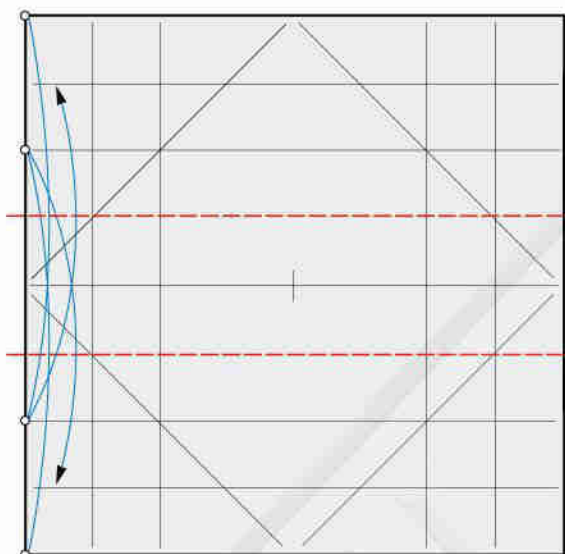

5

2 pieghe a valle

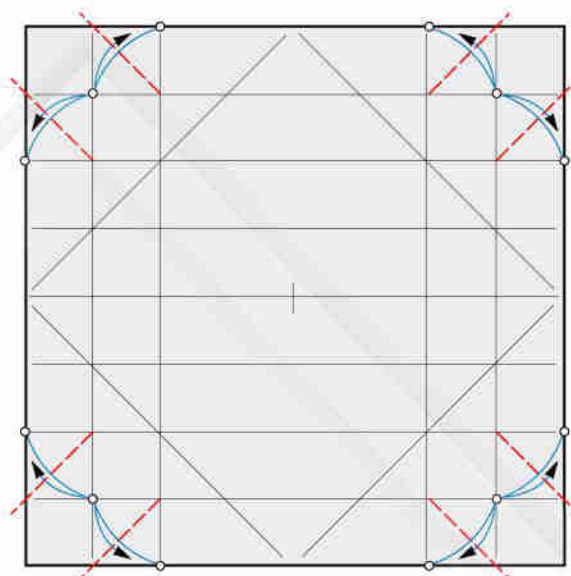

6

8 pieghe a valle

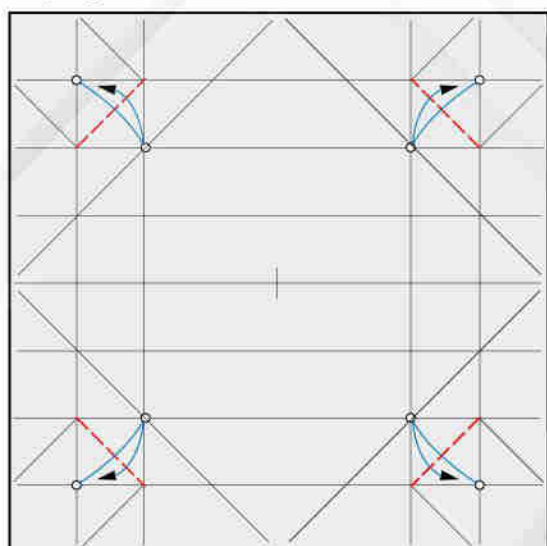

7

4 pieghe a valle

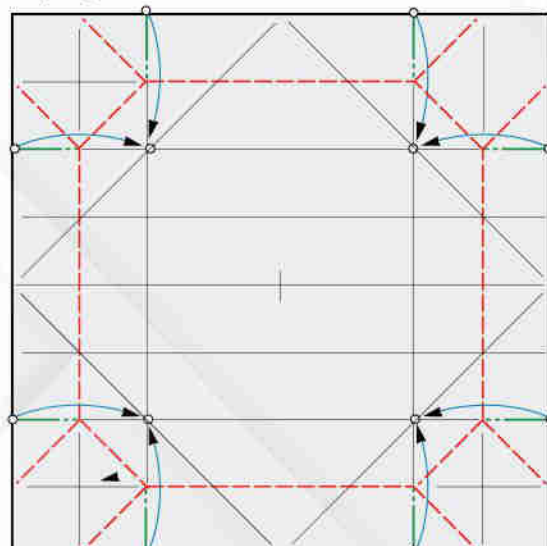

8

Ruotate ripiegando a valle ed a monte

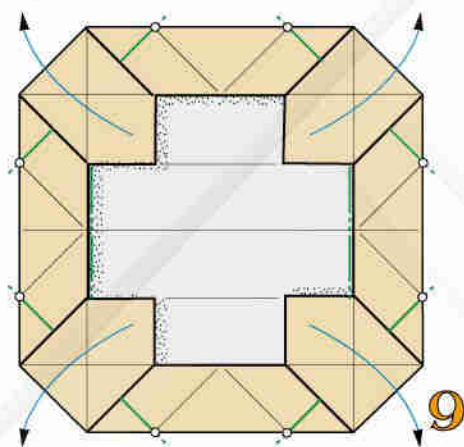

9

4 pieghe a monte e ruotate

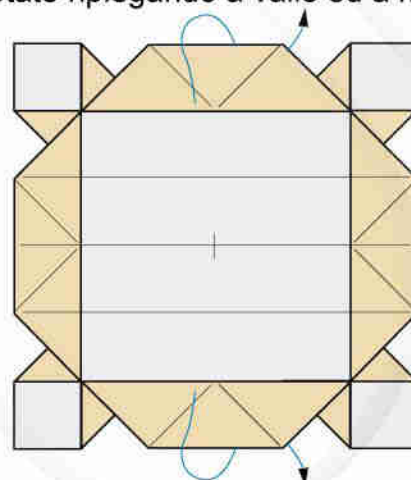

10

Rovesciate all'esterno le 2 superfici trapezoidali.
È necessario aprire il modello per agevolare l'operazione

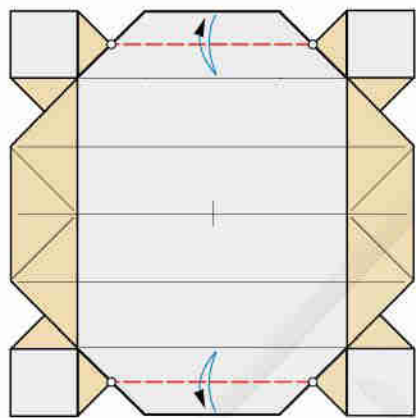

11

2 pieghe a valle

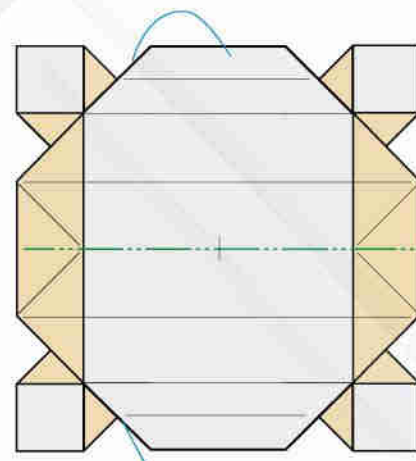

12

Ruotate ripiegando a monte

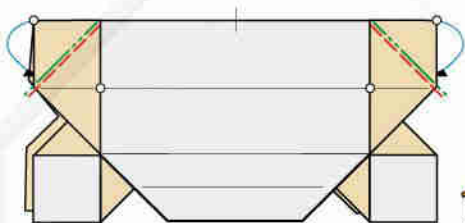

13

2 pieghe rovesce interne

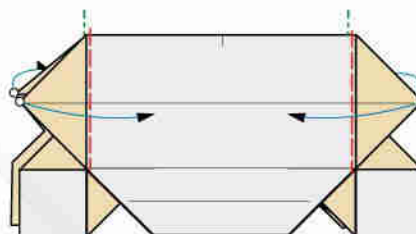

14

Ruotate i 4 vertici indicati ripiegando a valle

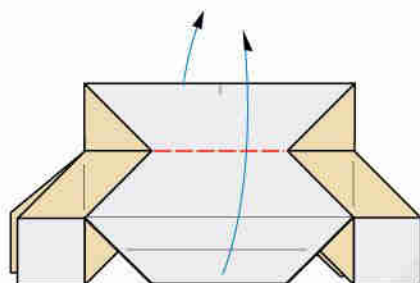

15

Aprite 3D ripiegando a valle

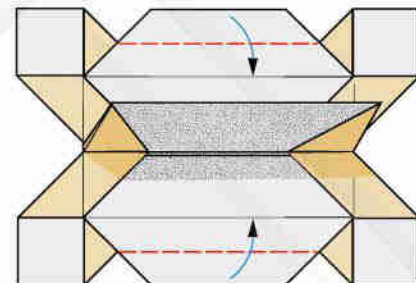

16

2 pieghe a valle e ruotate 90%

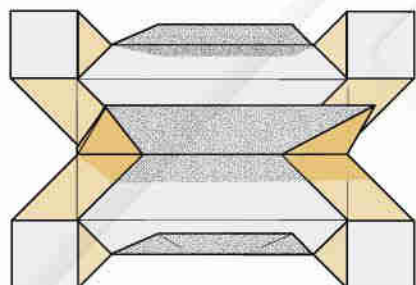

17

Modulo semipiastra 3D-3 ultimato

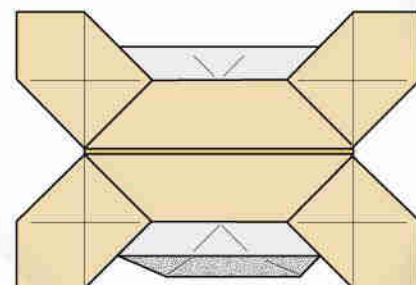

REALIZZAZIONE DI UN POLIEDRO (ICOSAEDRO)

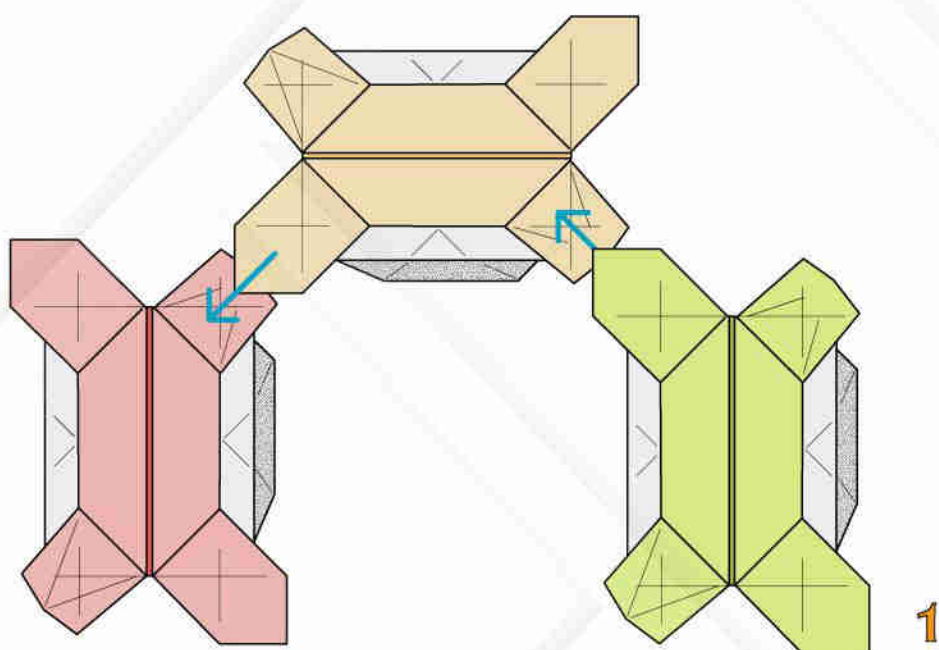

Unire e bloccare 3
moduli nel solito modo

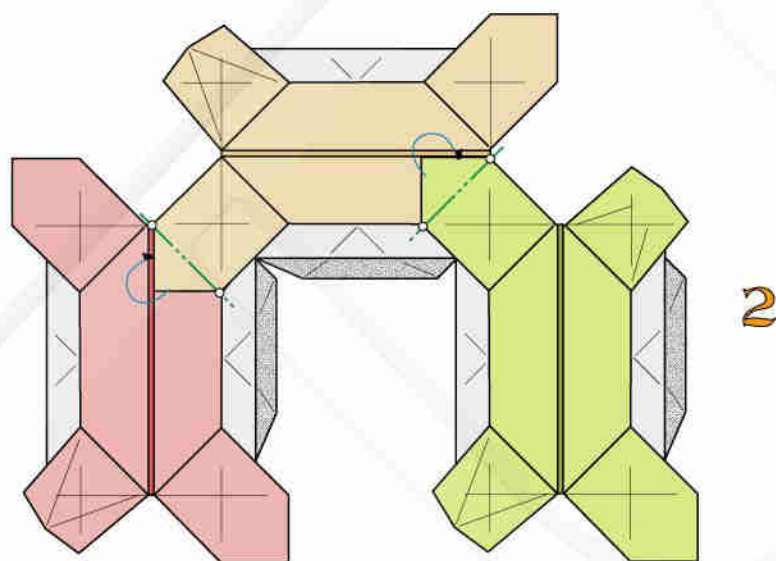

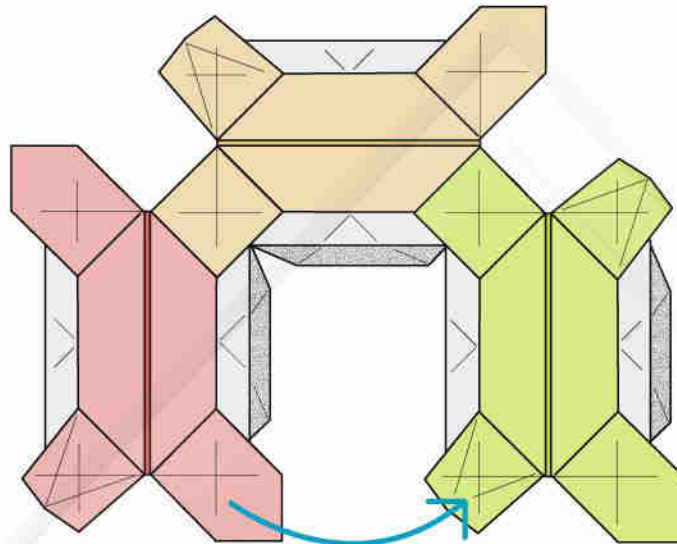

Unione dei 3 moduli
nel solito modo

3

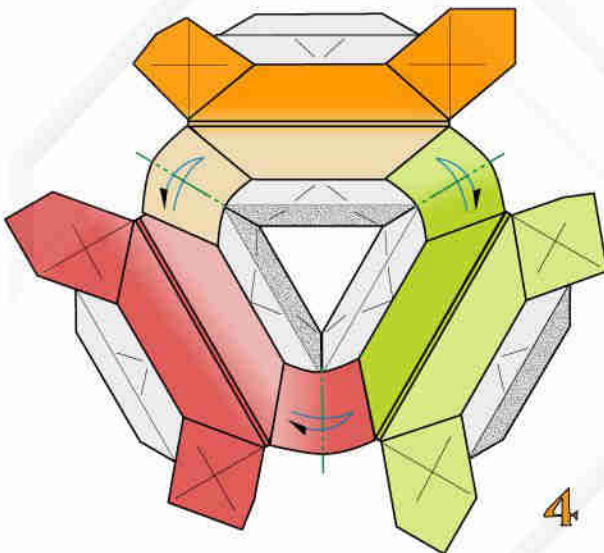

3 pieghe a monte

4

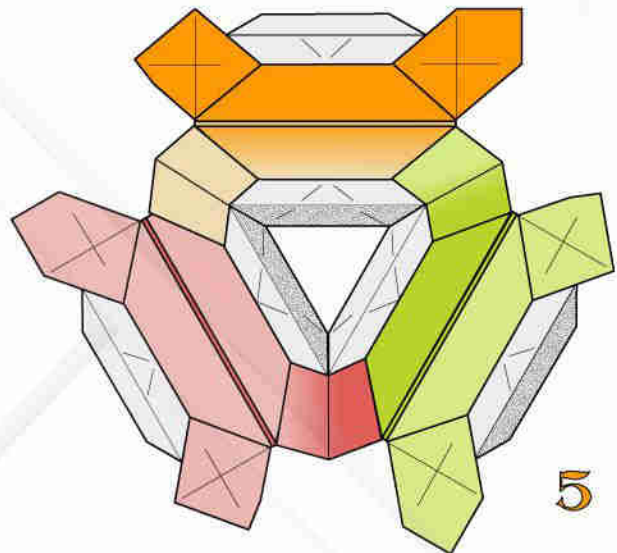

Unione di 3 moduli completata

5



**ICOSAEDRO REALIZZATO
UNENDO 5 MODULI PER
OGNI VERTICE.
SOLIDO PLATONICO CON 20
FACCE TRIANGOLARI E 30
SPIGOLI SEMIPIASTRA "3D-3"**

**30 fogli carta quadrata
bicolore robusta**

Semipiastra 3D-4

Modulo di complessa realizzazione indicato soprattutto per la costruzione di poliedri

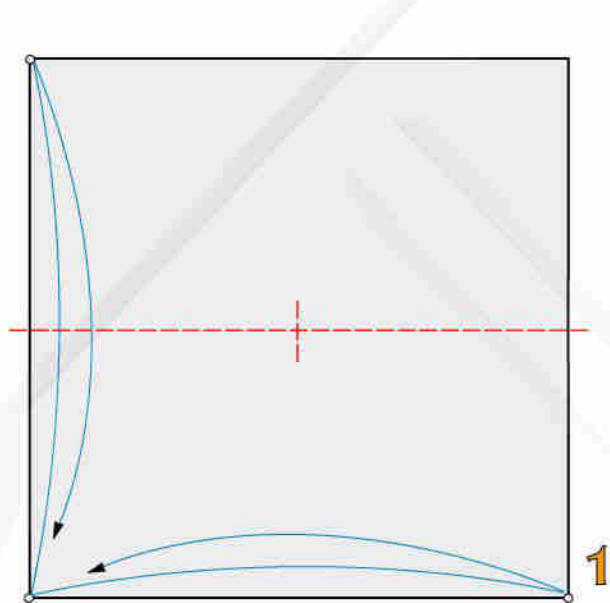

2 pieghe a valle

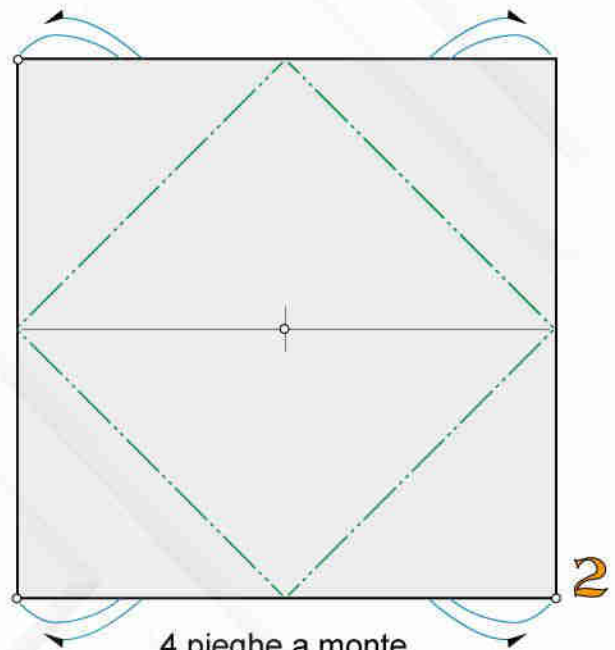

4 pieghe a monte

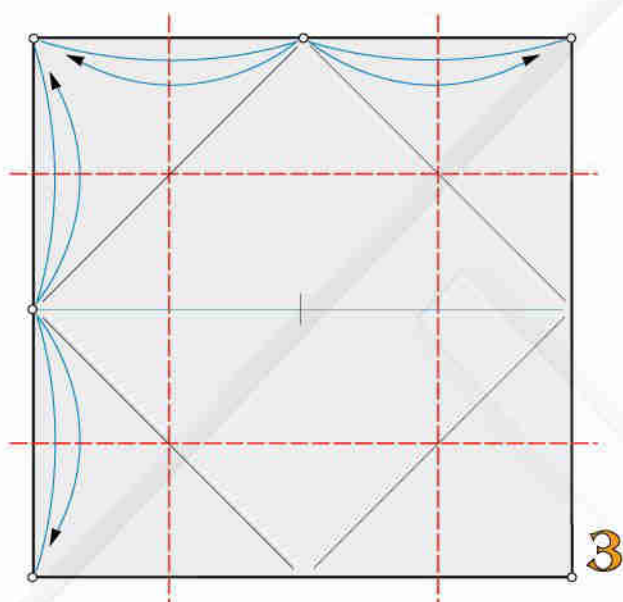

4 pieghe a valle

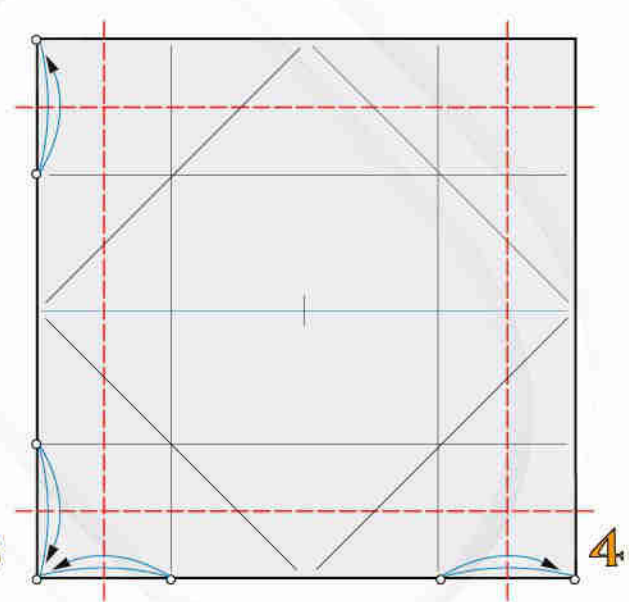

4 pieghe a valle

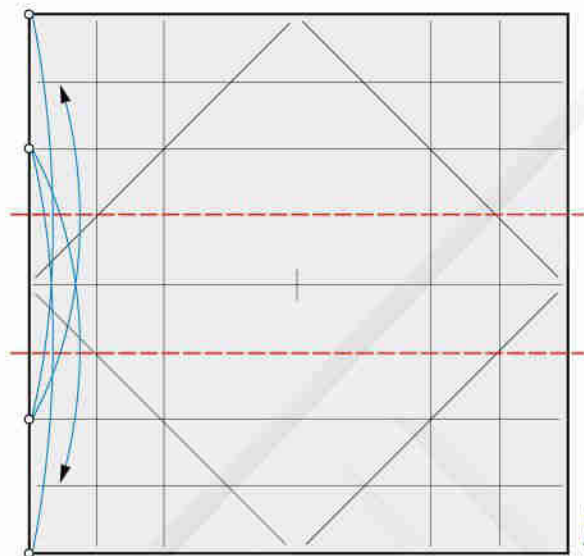

5

2 pieghe a valle

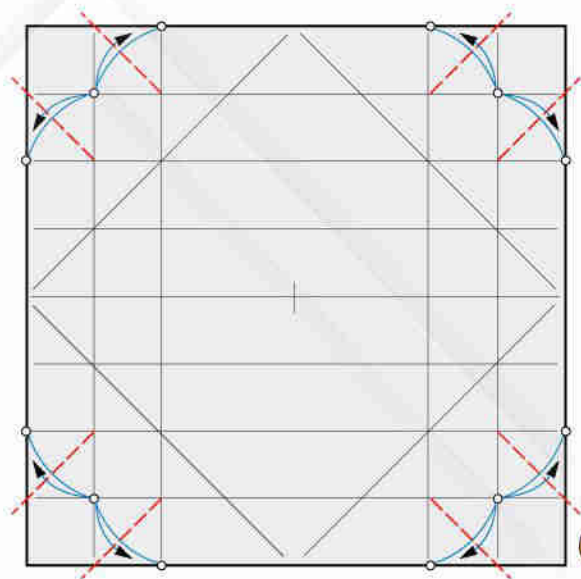

6

8 pieghe a valle

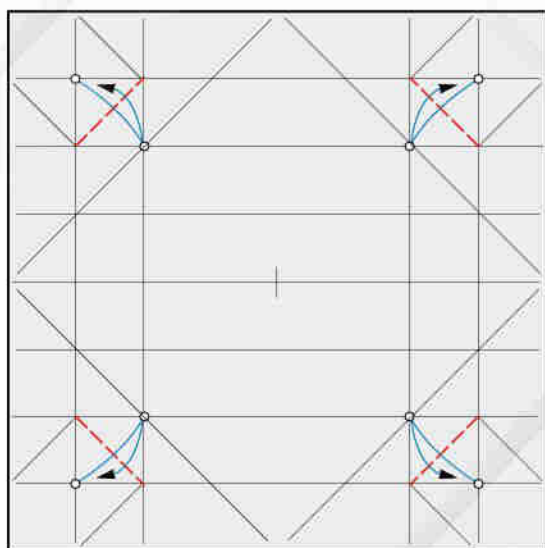

7

4 pieghe a valle

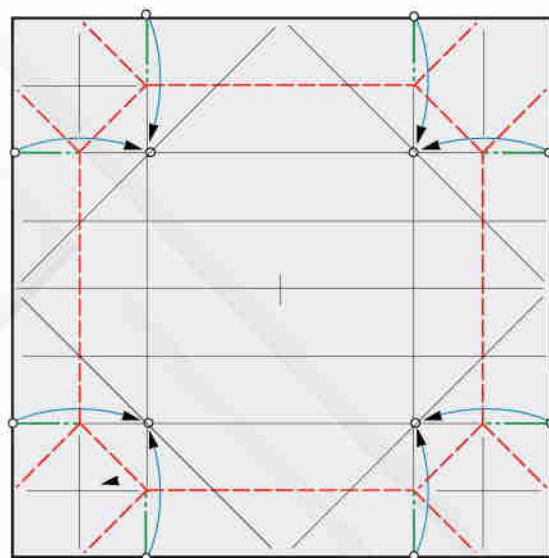

8

Ruotate ripiegando a valle ed a monte

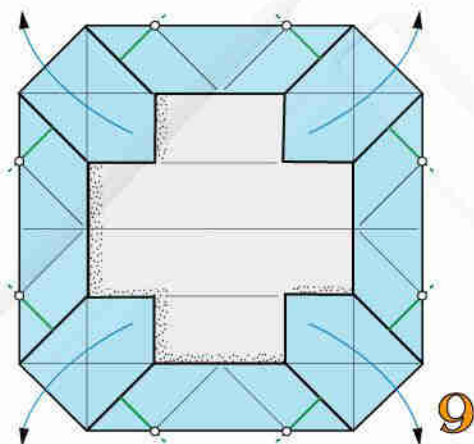

9

4 pieghe a monte e ruotate

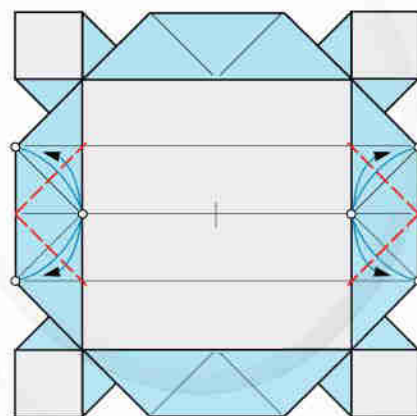

10

4 pieghe a valle

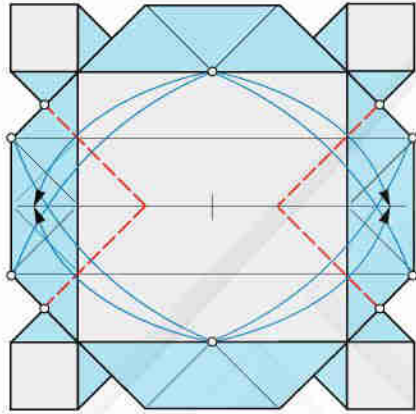

11

4 pieghe a valle

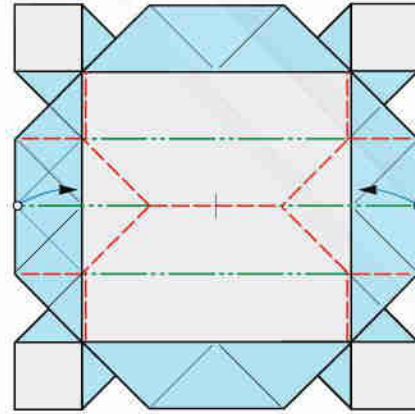

12

4 pieghe a valle e richiudete 3D

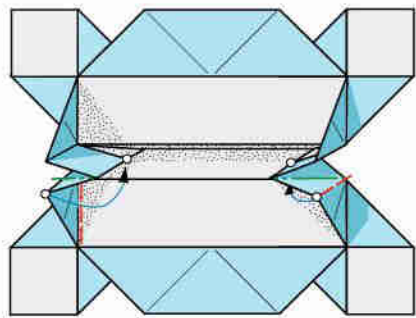

13

Piegando a monte ruotate i vertici indicati

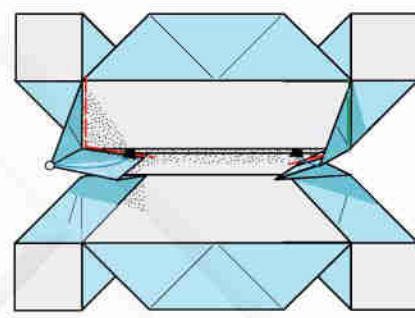

14

Piegando a valle ruotate ed intascate i vertici indicati

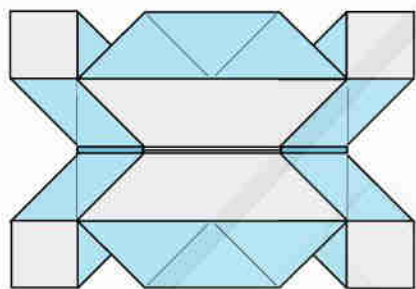

15

Ribaltate

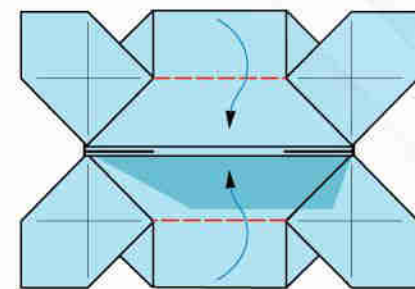

16

2 pieghe rovesce interne

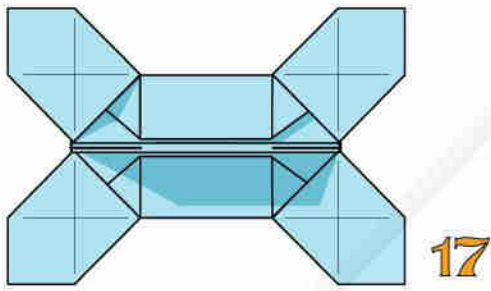

Mezza piastra 3D-4 ultimata

REALIZZAZIONE DI UN POLIEDRO (ICOSAEDRO)

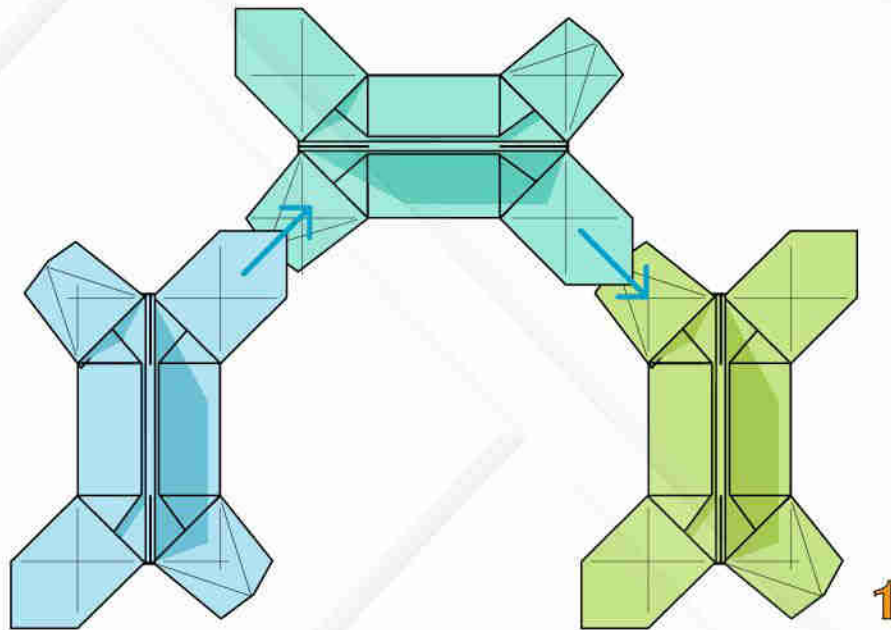

1

Unire e bloccare 3
moduli nel solito modo

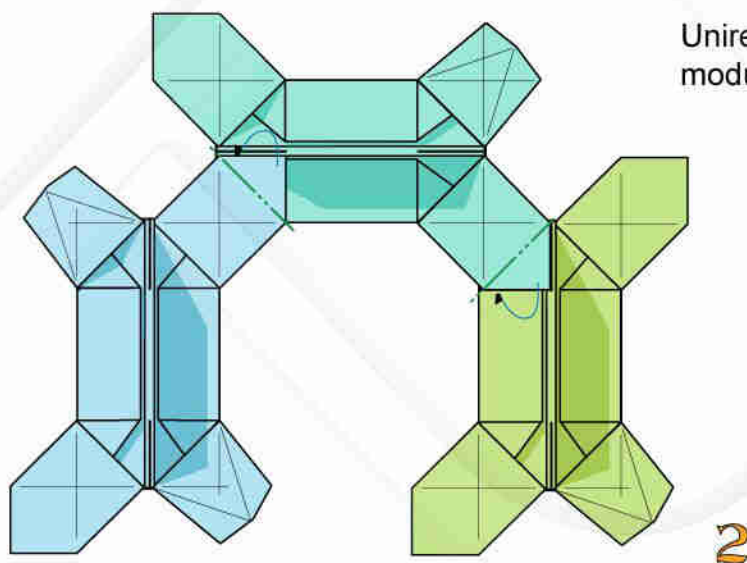

2

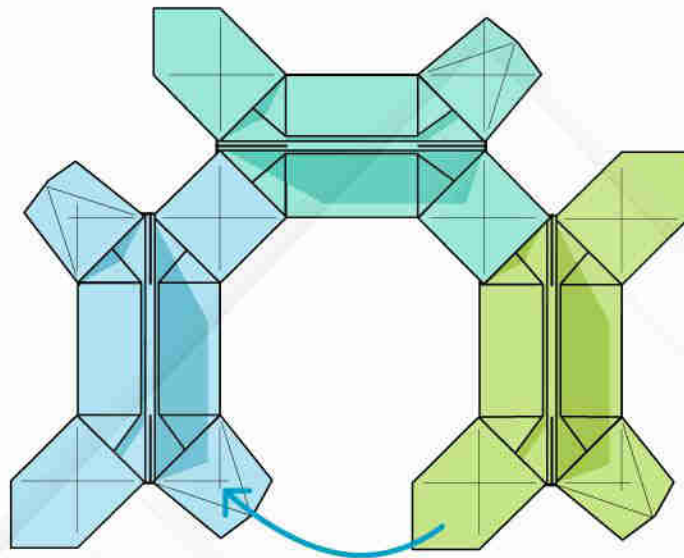

3

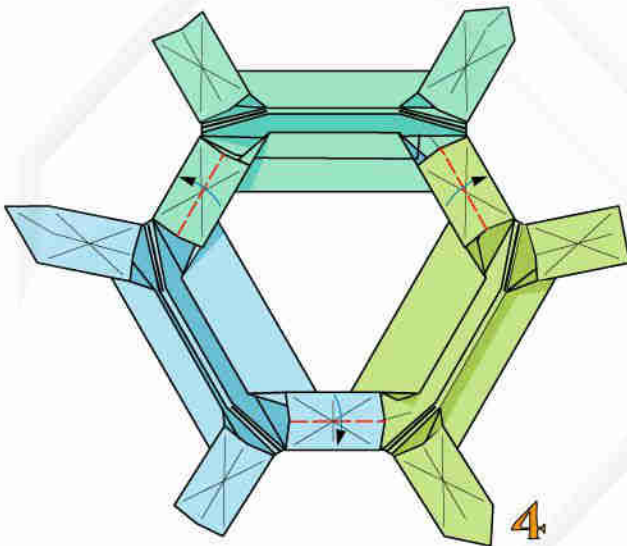

4

3 pieghe a valle e ruotate

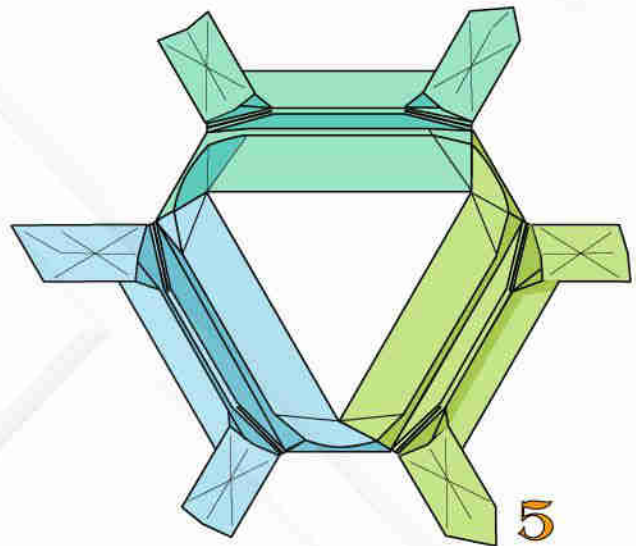

5

Unione completata



**ICOSAEDRO REALIZZATO
UNENDO 5 MODULI PER
OGNI VERTICE.
SOLIDO PLATONICO CON 20
FACCE TRIANGOLARI E 30
SPIGOLI SEMIPIASTRA "3D-4"**

**30 fogli carta quadrata
monocolore robusta**

Asta

Le aste sono semplici elementi rettilinei dotati solamente di 2 appendici d'aggancio alle estremità. Adoperate carta di medio peso o leggera.

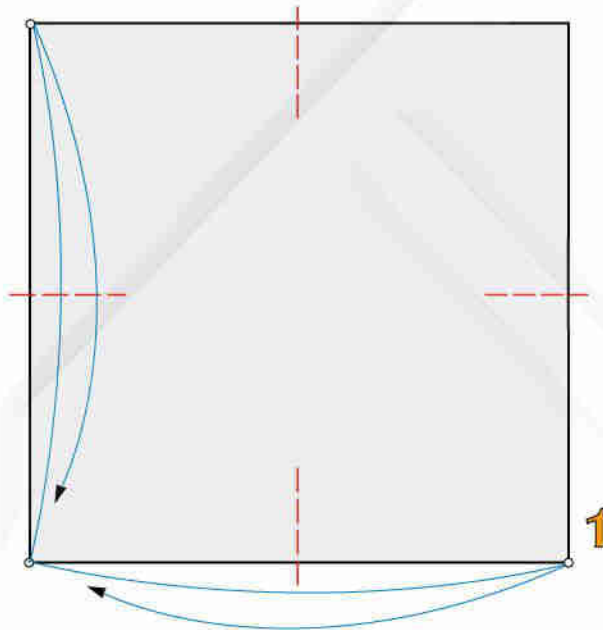

4 pieghe a valle

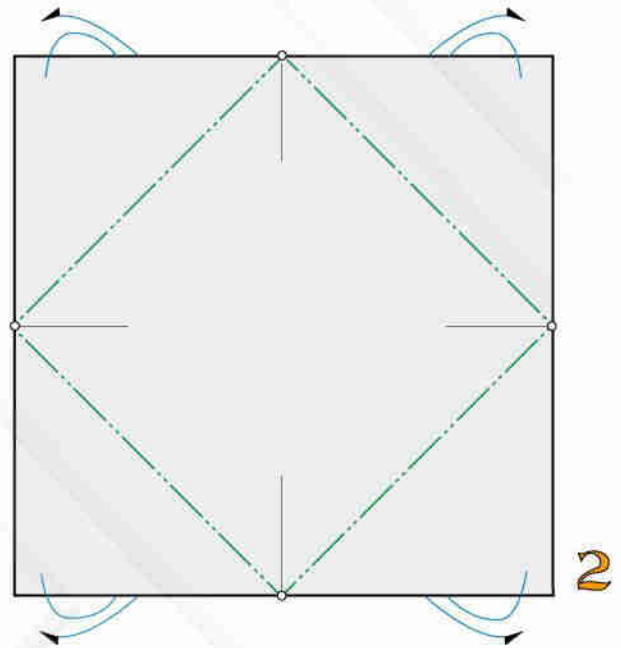

4 pieghe a monte

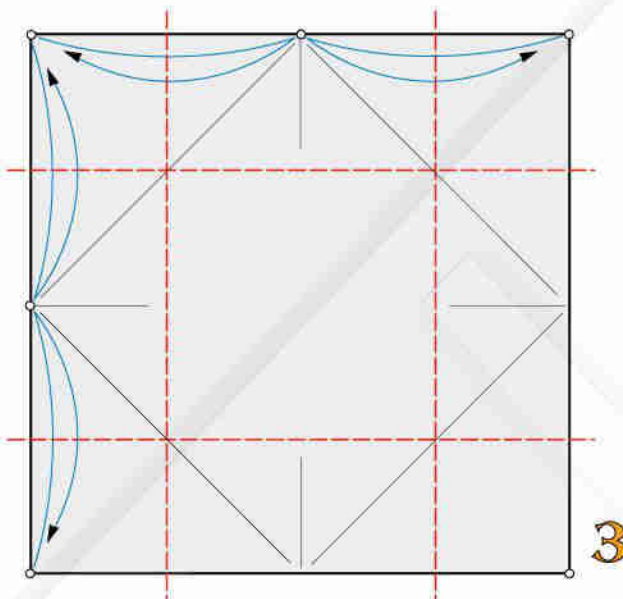

4 pieghe a valle

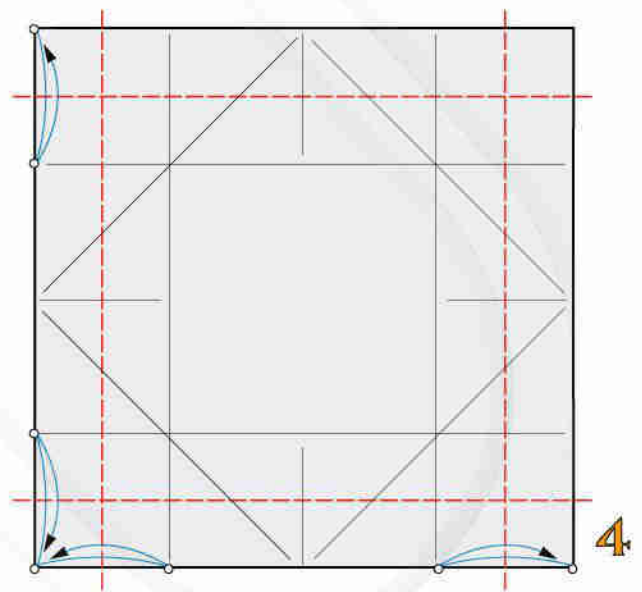

4 pieghe a valle

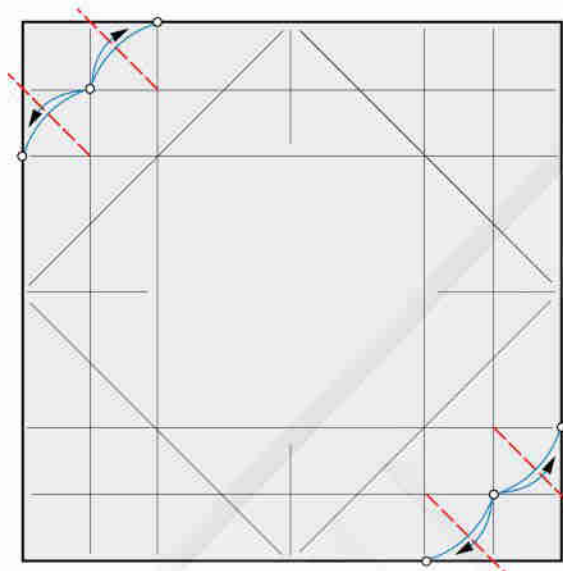

4 pieghe a valle

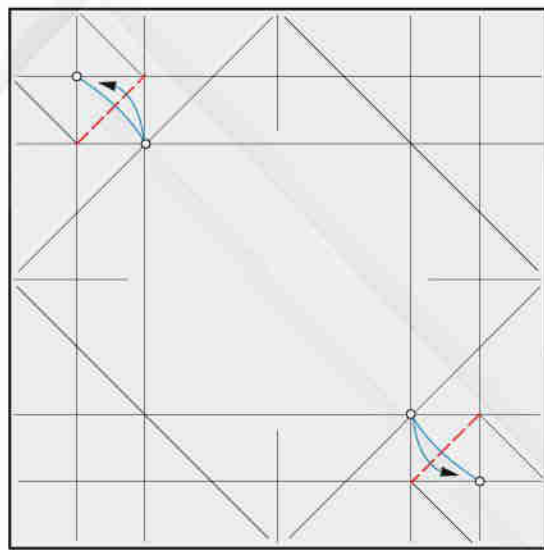

2 pieghe a valle

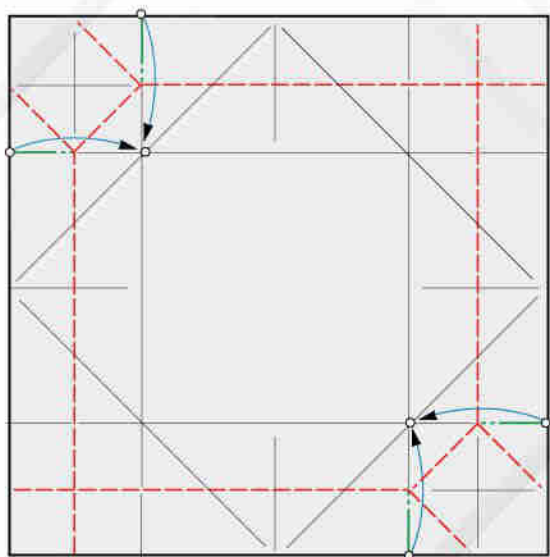

Ruotate ripiegando a valle ed a monte

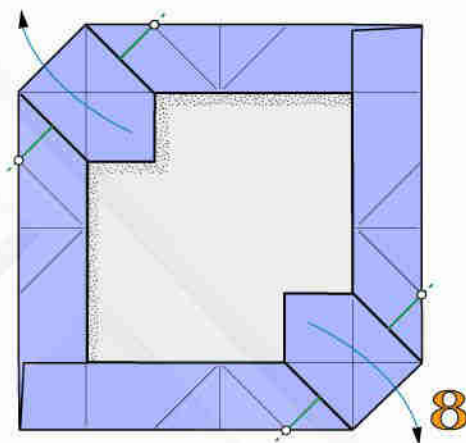

2 pieghe a monte e ruotate

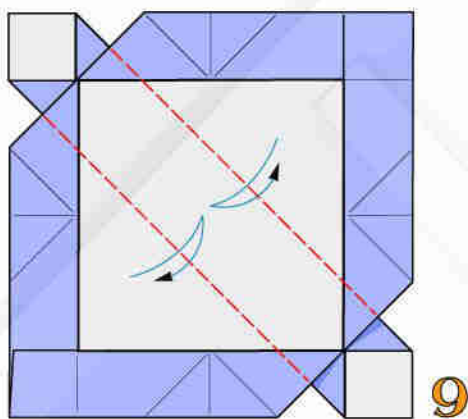

2 pieghe a valle

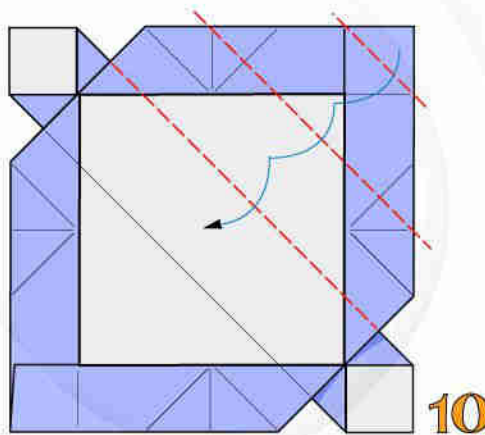

3 pieghe a valle in successione e ruotate

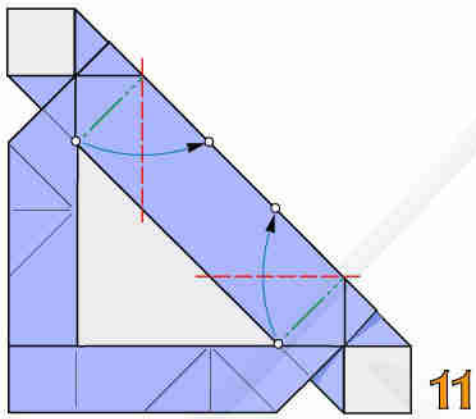

2 pieghe a valle, 2 a monte e ruotate

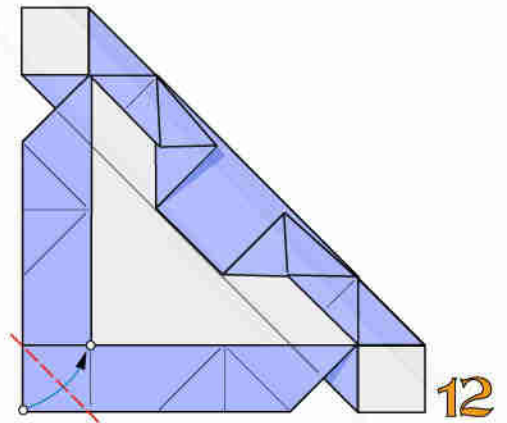

1 piega a valle e ruotate

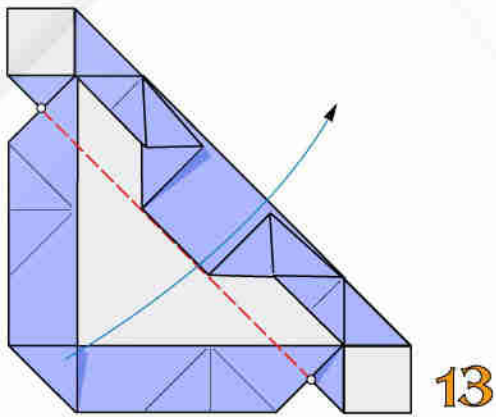

1 piega a valle e ruotate

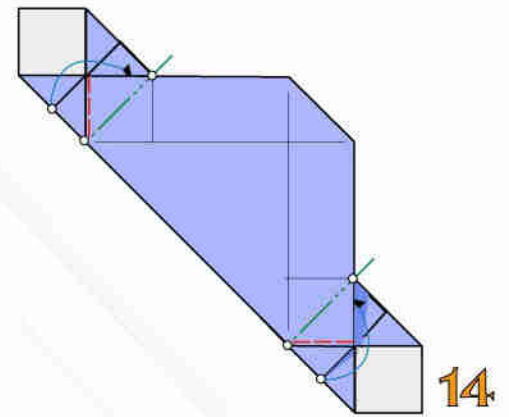

2 pieghe a valle, 2 a monte e ruotate all'interno

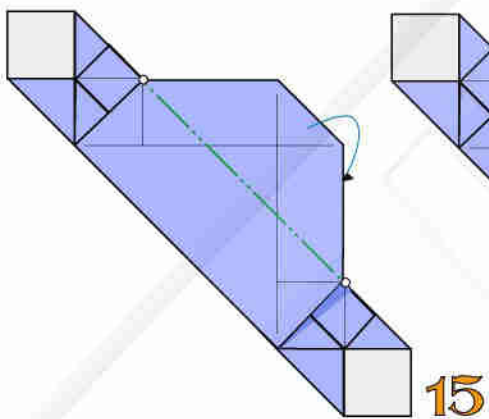

1 piega a monte ed intascate bloccando il modello

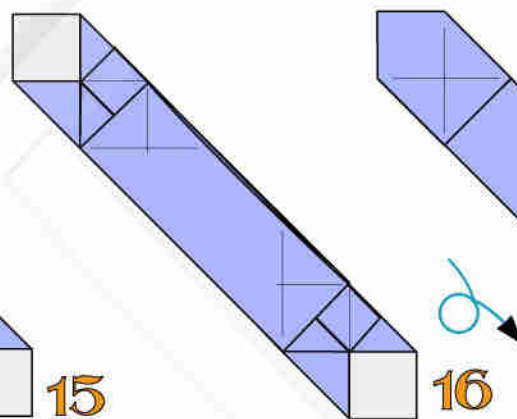

Asta ultimata.

Asta 4/5

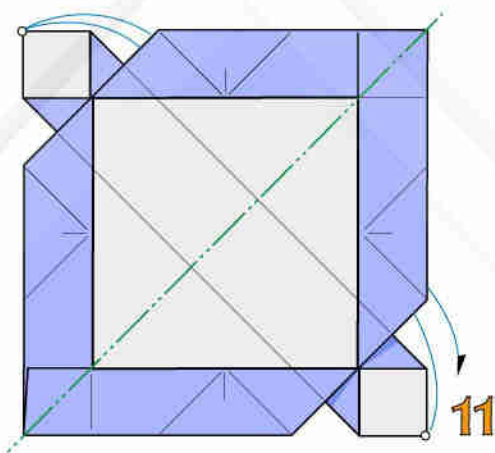

Partite dalla fig. n. 10 di "Asta".
1 piega a monte

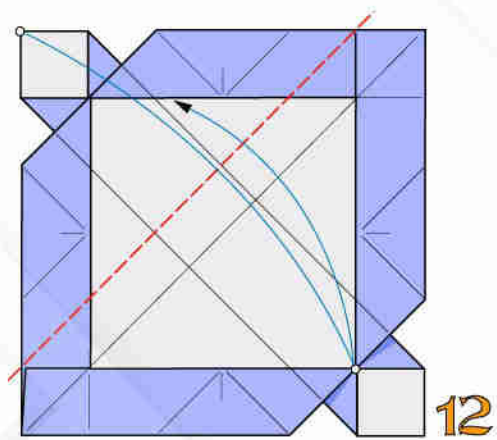

1 piega a valle

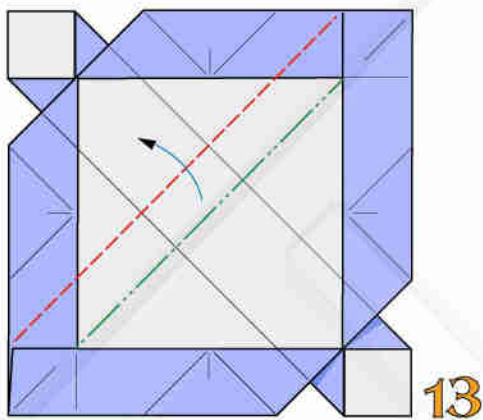

Ruotate ripiegando a valle
ed a monte

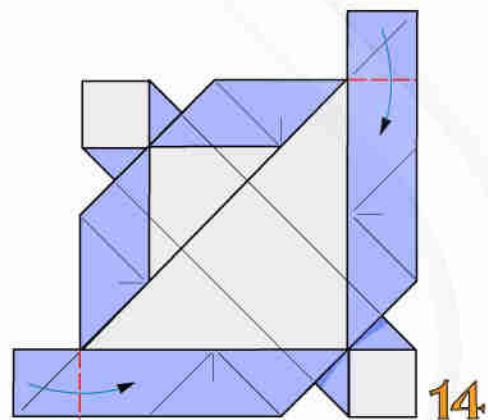

2 pieghe a valle e ruotate

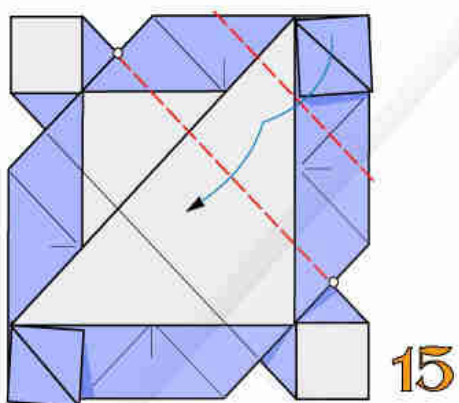

2 pieghe a valle in successione e ruotate

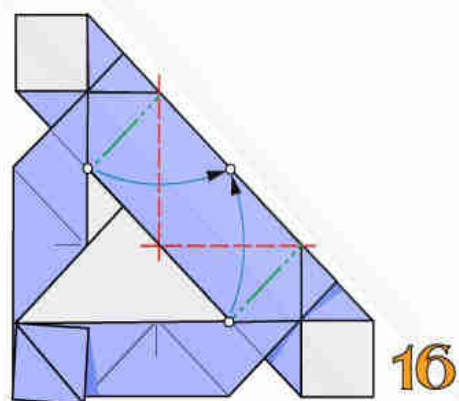

2 pieghe a valle, 2 a monte e ruotate

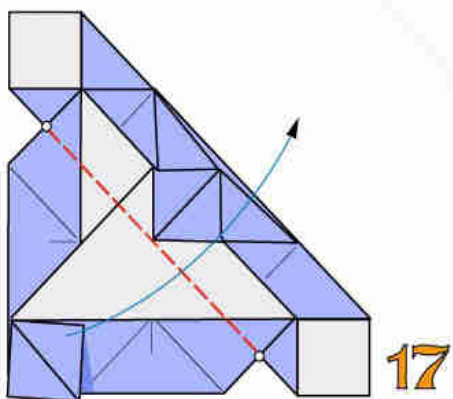

1 piega a valle e ruotate

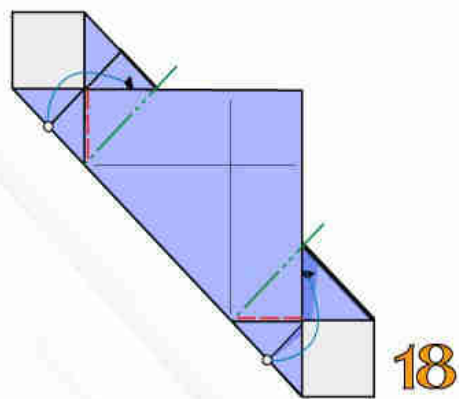

2 pieghe a valle, 2 a monte e ruotate all'interno

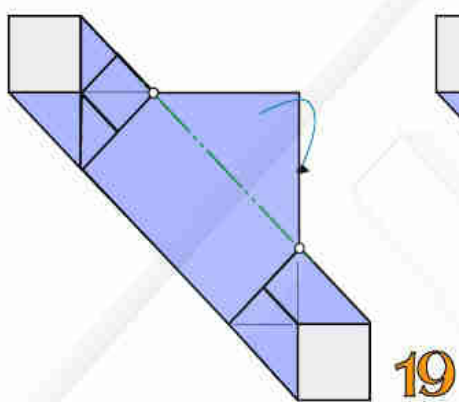

1 piega a monte ed intascate bloccando il modello

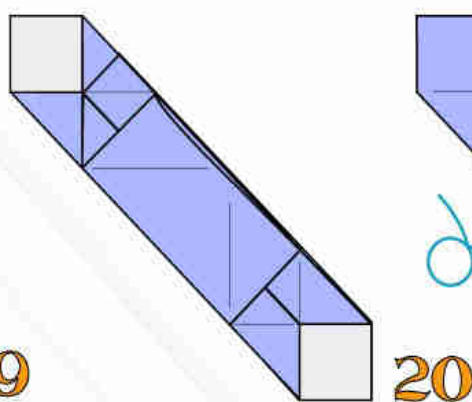

Asta 4/5 ultimata.

Asta 3/5A

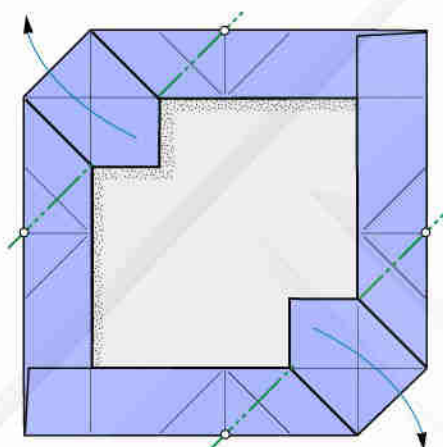

9

Partite dalla fig.n. 8 di "Asta".
2 pieghe a monte e ruotate

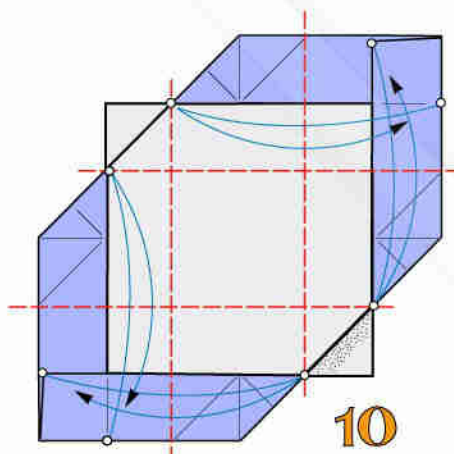

10

4 pieghe a valle

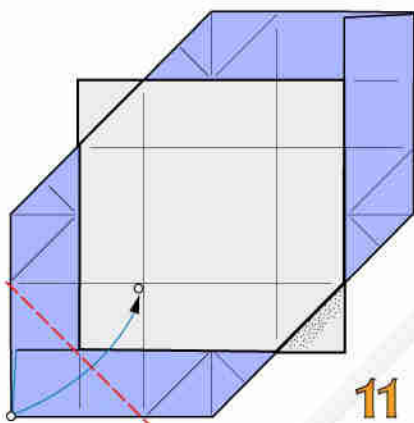

11

1 piega a valle e ruotate

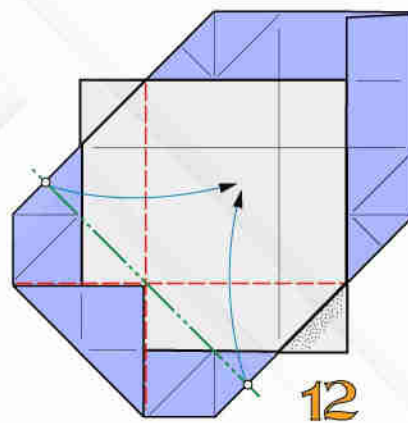

12

1 piega a monte e ruotate
ripiegando a valle

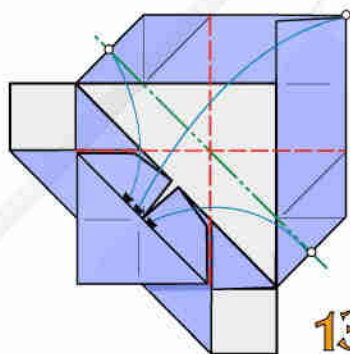

13

1 piega a monte e intascate
tutto ripiegando a valle

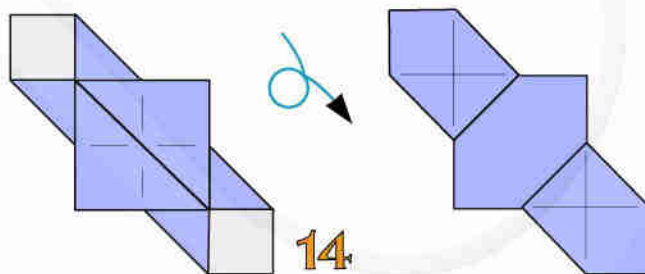

14

Asta 3/5 ultimata.

Asta 3/5B

Si dimezza il quadrato di partenza. Costruzione piuttosto difficoltosa.

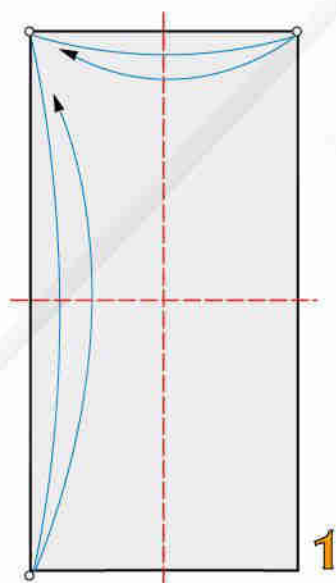

2 pieghe a valle

1

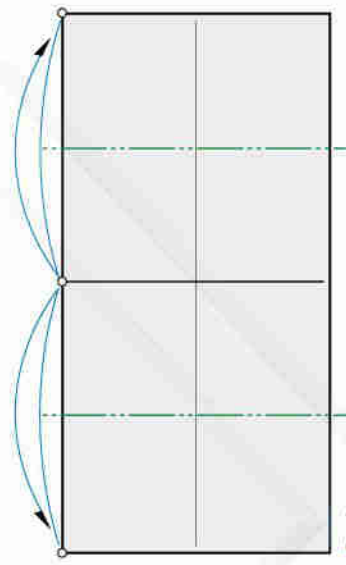

2 pieghe a monte

2

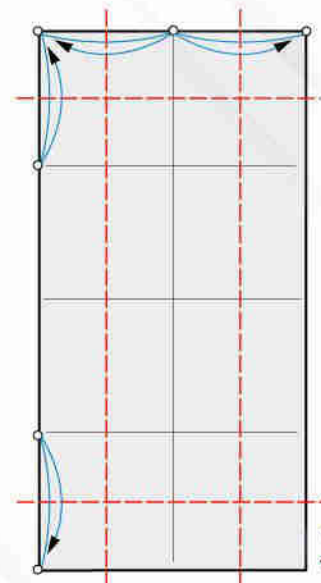

4 pieghe a valle

3

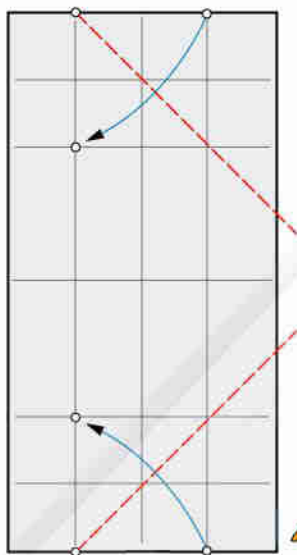

2 pieghe a valle,
ruotatee ribaltate

4

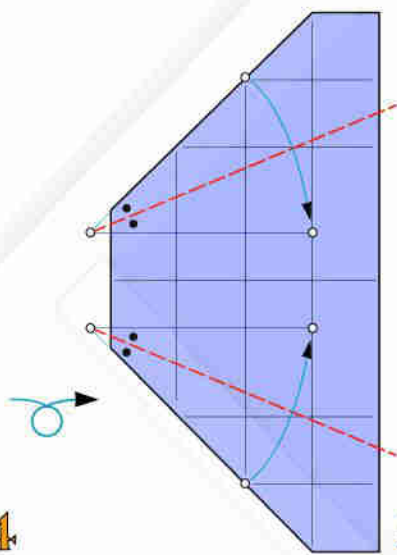

2 pieghe bisettrici
a valle e ruotate

5

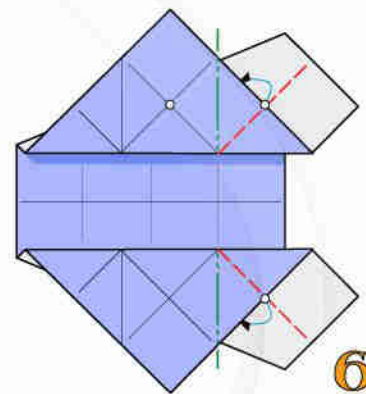

Mediante pieghe a monte
ed a valle rovesciate
all'interno i vertici indicati

6

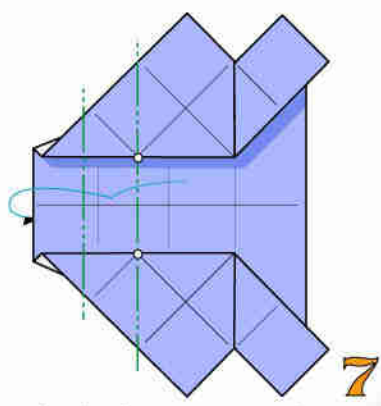

7
2 pieghe a monte in
successione e ruotate

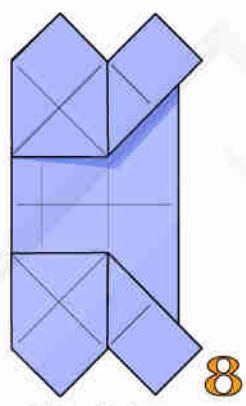

8
Ribaltate

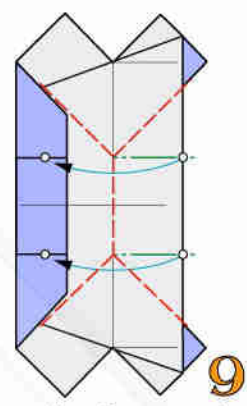

9
5 pieghe a valle, 2 a monte e ruotate
sovrapponendo 2 appendici

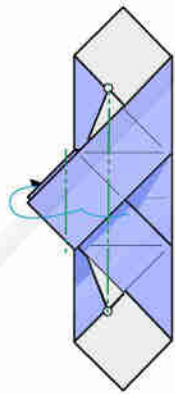

10
2 pieghe a monte in successione
e intascate bloccando il modello

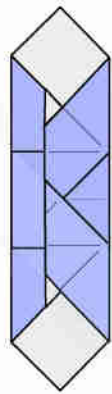

11
Asta 3/5 ultimata.
Ribaltate

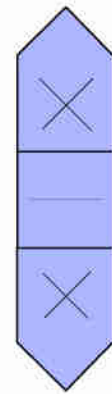

Asta 2/5

La più piccola delle aste.
Di costruzione un pò difficoltosa.

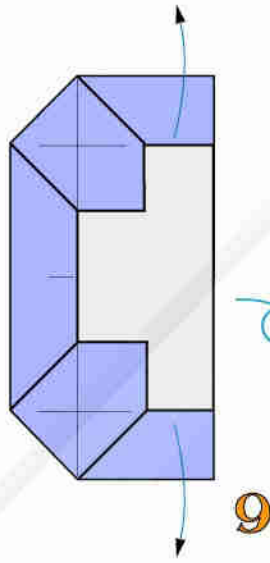

9
Partite dalla fig. n. 8
dell'asta C. Aprite
e ribaltate

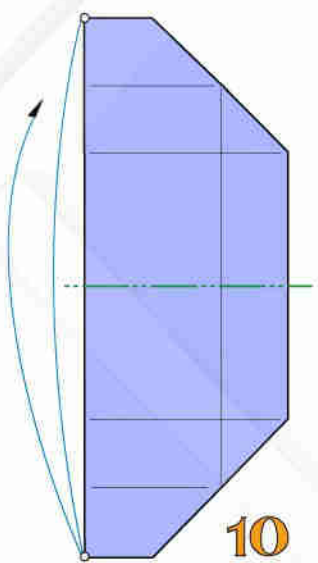

10
1 piega a monte

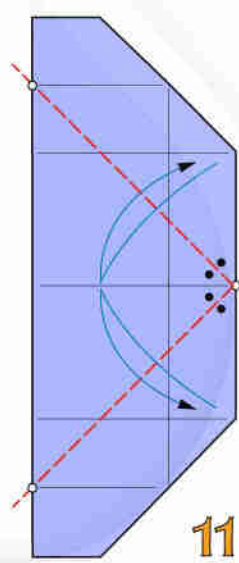

11
2 pieghe bisettrici a valle

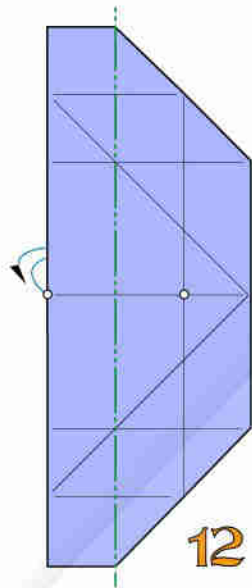

12

1 piega a monte

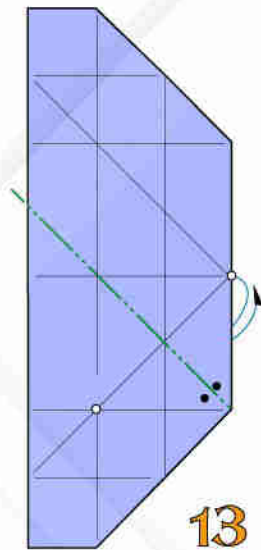

13

1 piega bisettrice a monte

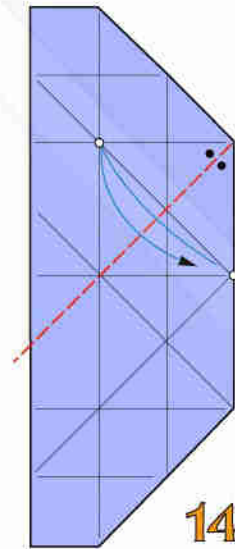

14

1 piega bisettrice a valle

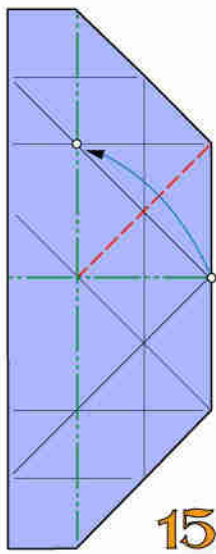

15

Ripiegando a valle ed a monte ruotate 3D

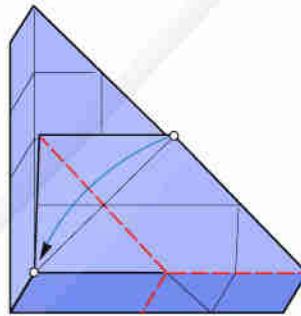

16

1 piega a valle e, ripiegando, ruotate

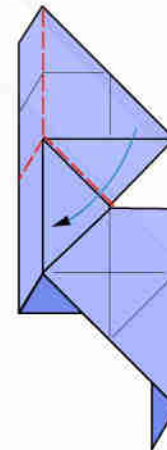

17

1 piega a valle e, ripiegando, ruotate

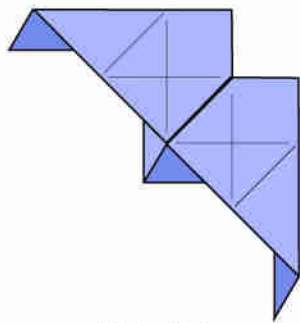

Ribaltate

18

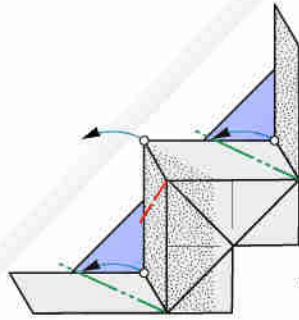

19

2 pieghe a monte, 1 a valle e comprimate 2D

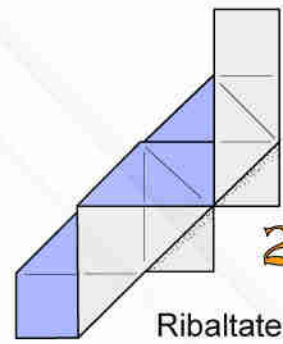

20

Ribaltate

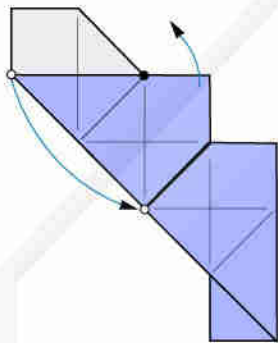

21

Effettuate una rotazione avente come perno il punto nero indicato

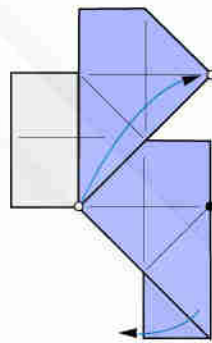

22

Effettuate una rotazione avente come perno il punto nero indicato

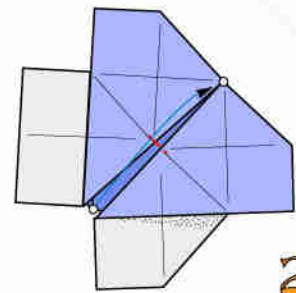

23

Mediante una piega a valle seminascosta ruotate il vertice interno

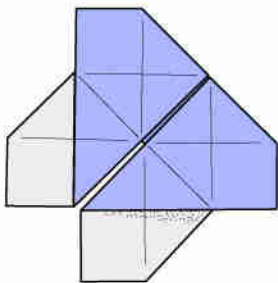

24

Ribaltate

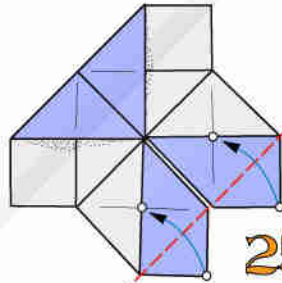

25

2 pieghe a valle e ruotate

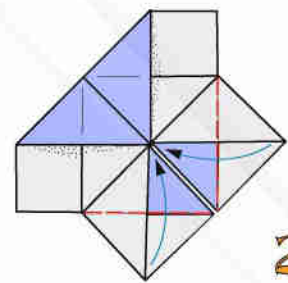

26

2 pieghe a valle e ruotate

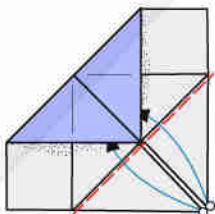

27

2 pieghe a valle e intascate

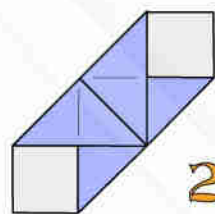

28

Asta 2/5 ultimata.

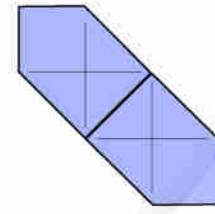

Asta a C

Elemento di fondamentale importanza. Dimezzate il foglio quadrato di partenza.

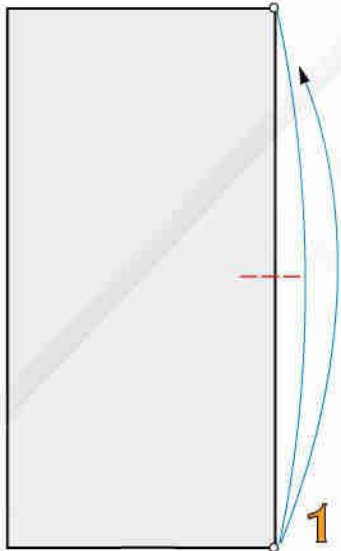

1 piccola piega a valle

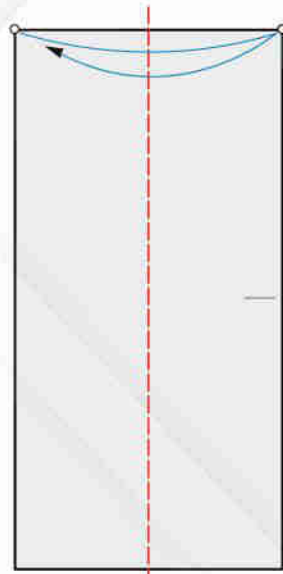

1 piega a valle

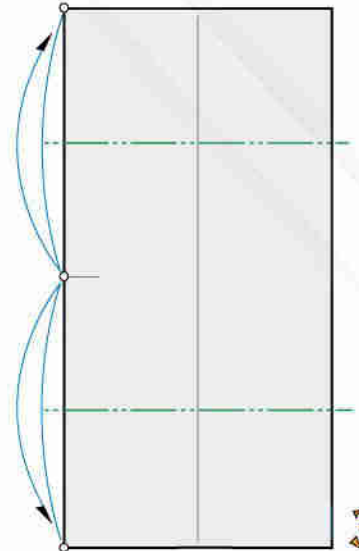

2 pieghe a monte

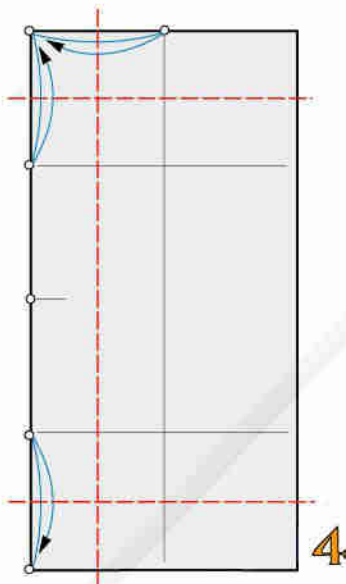

3 pieghe a valle

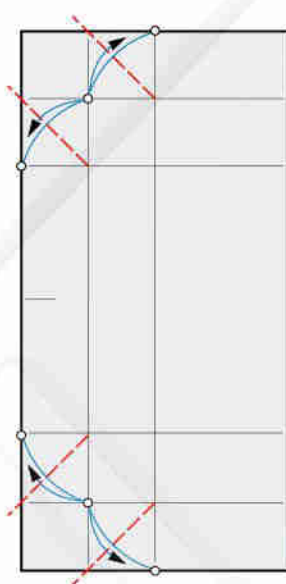

4 pieghe a valle

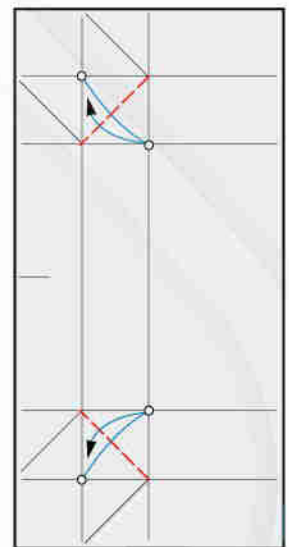

2 pieghe a valle

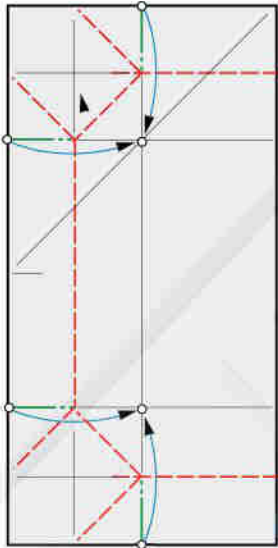

7

Ruotate ripiegando a valle ed a monte

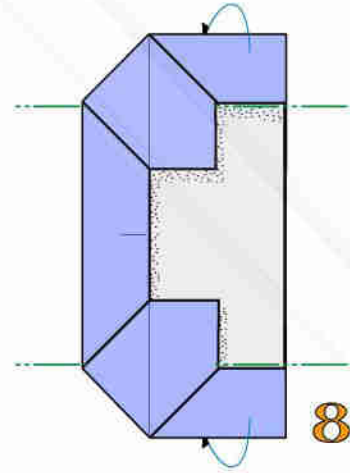

8

Ruotate ripiegando 2 volte a monte

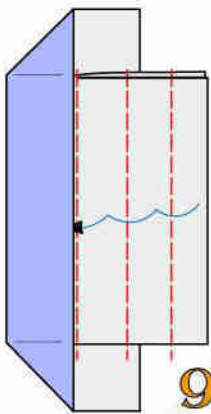

9

3 pieghe a valle ed intascate ruotando in successione

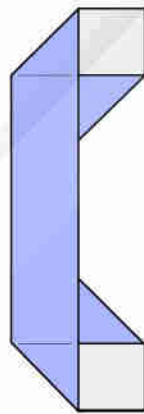

10

Asta a "C" ultimata

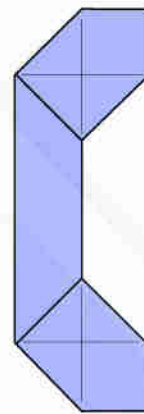

Asta ad S

sinistra

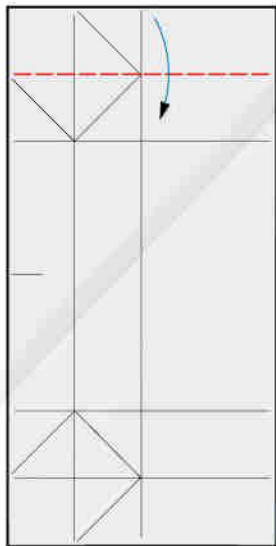

7

Partite dalla fig. n. 6
dell' asta a C.
1 piega a valle e ruotate

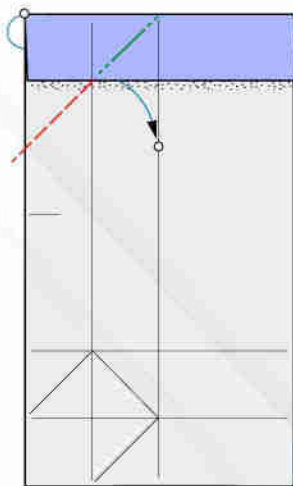

8

1 piega rovescia
interna

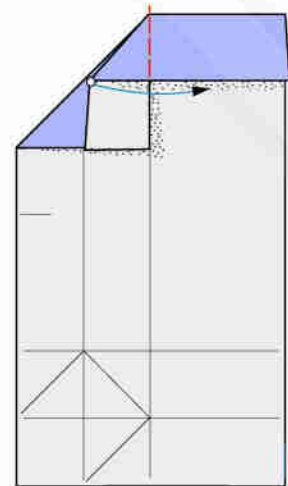

9

1 piega a valle e ruotate

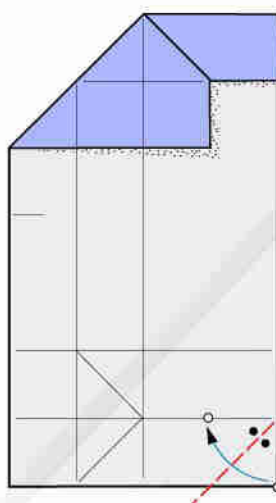

10

1 piega a valle e ruotate

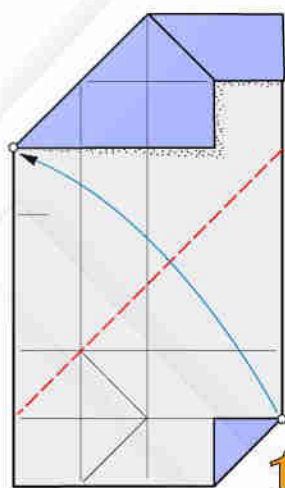

11

1 piega a valle e ruotate

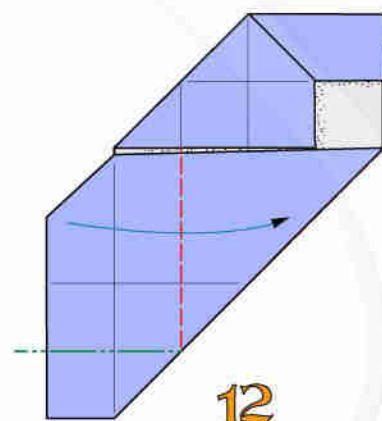

12

Ruotate ripiegando a
valle ed a monte

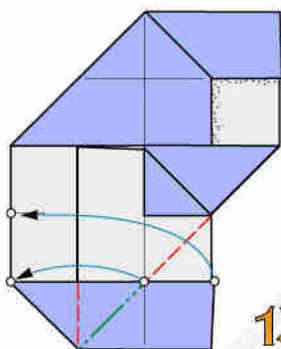

13

1 piega a valle e ruotate ripiegando

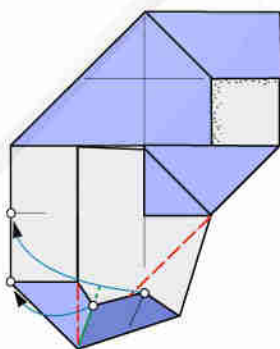

14

1 piega rovescia interna

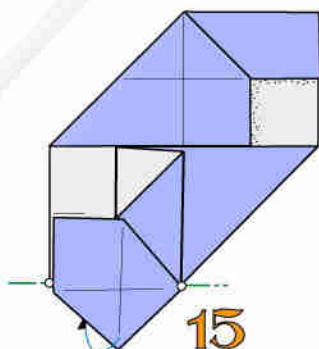

15

1 piega a monte e ruotate

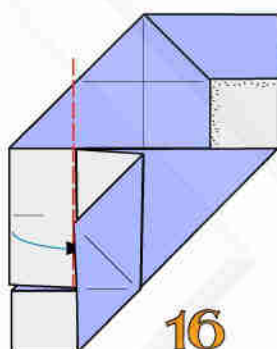

16

1 piega a valle e ruotate intascando

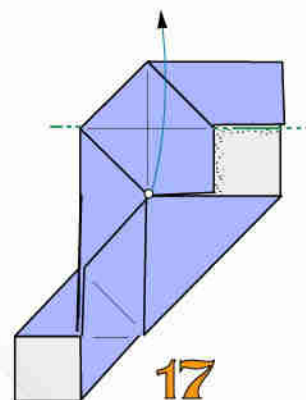

17

1 piega a monte e ruotate estraendo

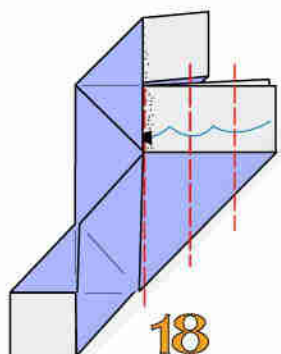

18

3 pieghe a valle in successione e ruotate intascando

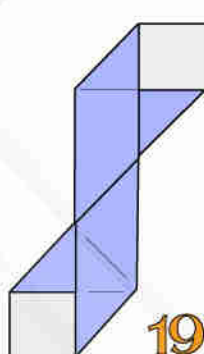

19

Asta ad S sinistra ultimata.

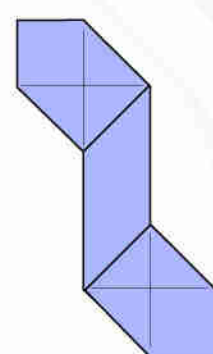

Asta ad S

destra

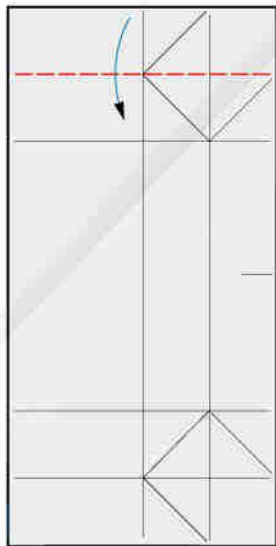

7

Partite dalla fig. n. 6
dell' asta a C.
1 piega a valle e ruotate

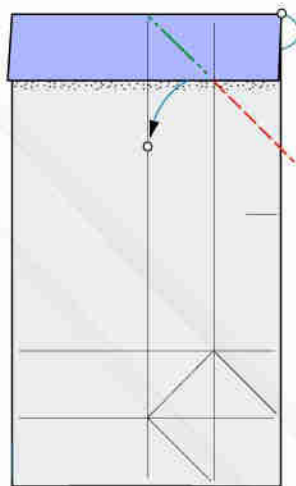

8

1 piega rovescia
interna

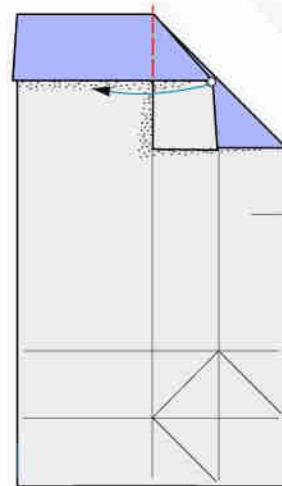

9

1 piega a valle e ruotate

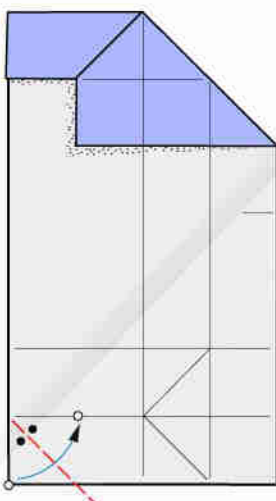

10

1 piega a valle e ruotate

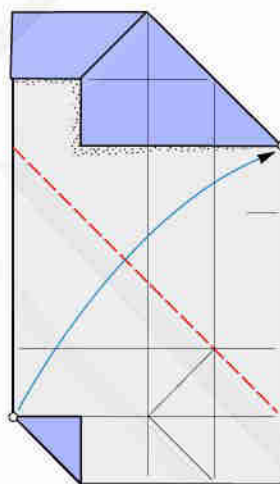

11

1 piega a valle e ruotate

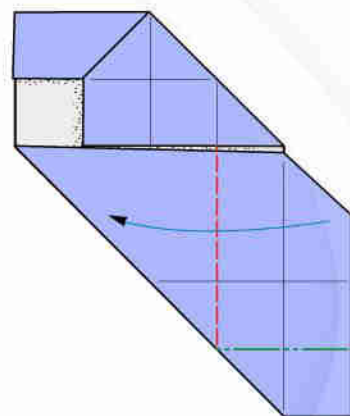

12

Ruotate ripiegando a
valle ed a monte

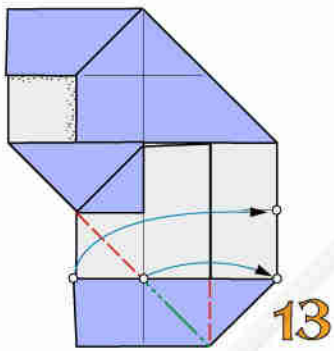

13
1 piega a valle e ruotate ripiegando

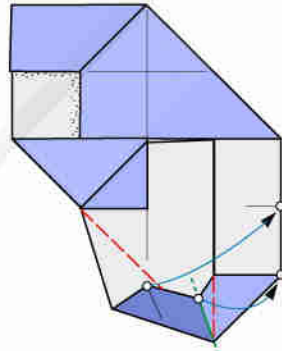

14
1 piega rovescia interna

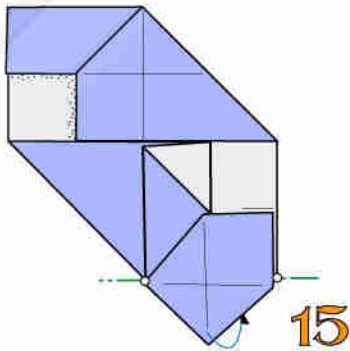

15
1 piega a monte e ruotate

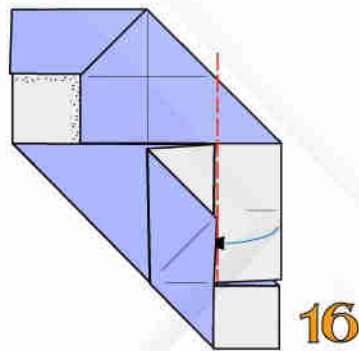

16
1 piega a valle e ruotate intascando

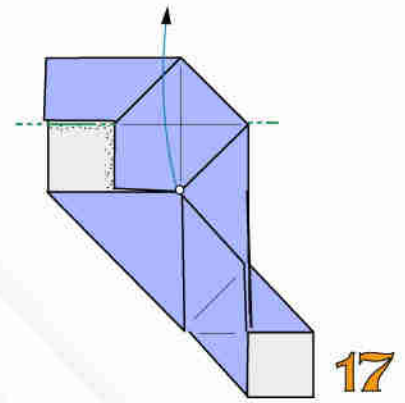

17
1 piega a monte e ruotate estraendo

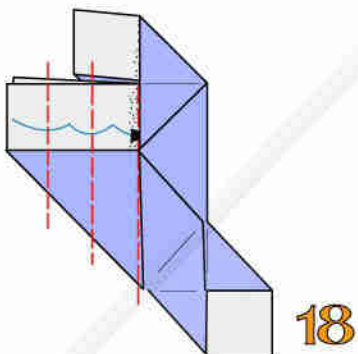

18
3 pieghe a valle in successione e ruotate intascando

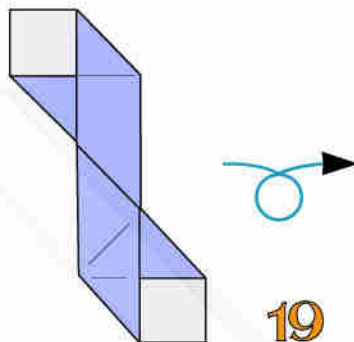

19
Asta ad S sinistra ultimata.

Gomito a 90°

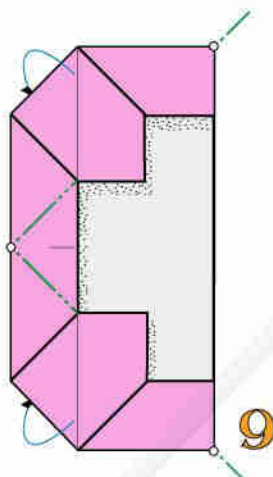

Partite dalla fig. n. 8 di "Asta a C".
2 pieghe a monte e ruotate

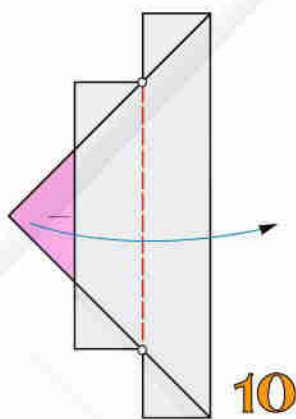

1 piega a valle e ruotate

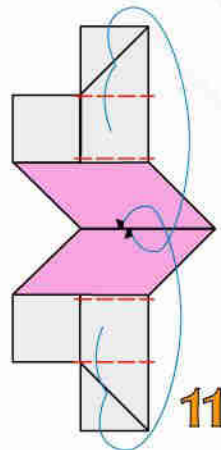

4 pieghe a valle ed intascate le appendici al centro

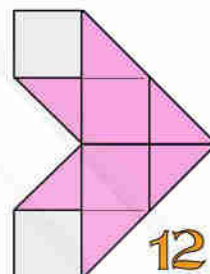

Gomito a 90° ultimato

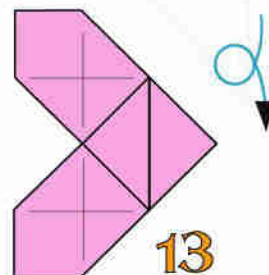

Gomito a 90°

smussato

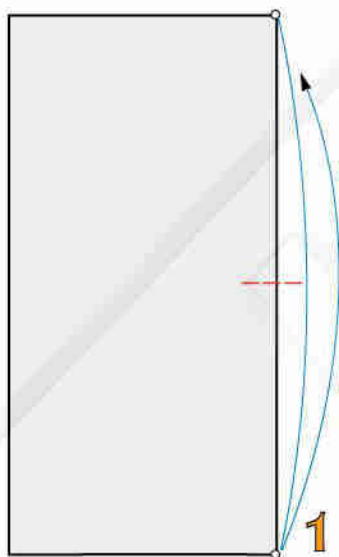

1 piccola piega a valle

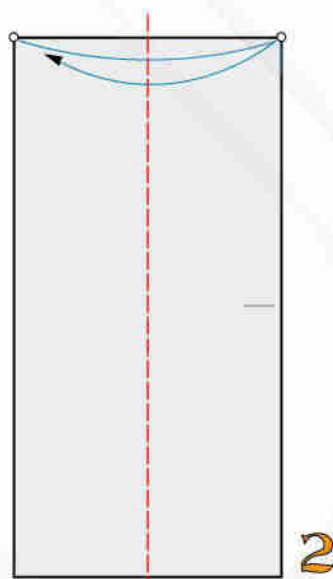

1 piega a valle

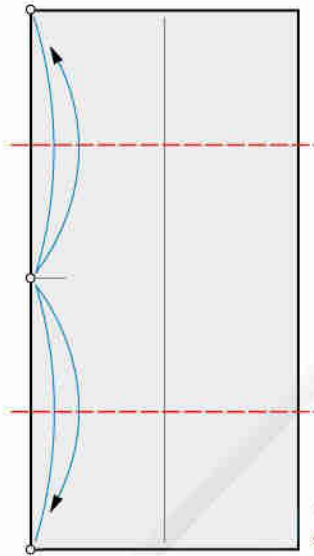

3

2 pieghe a valle

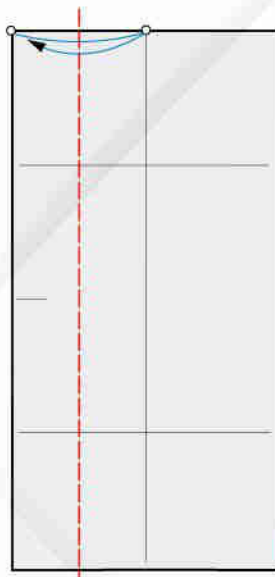

4

1 piega a valle

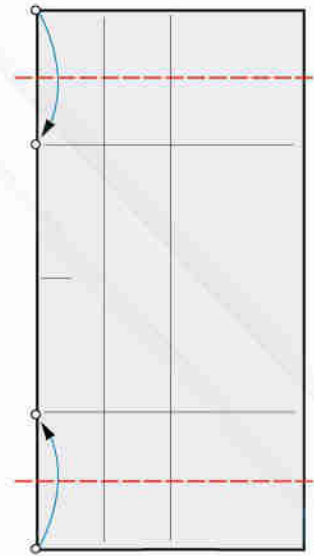

5

2 pieghe a valle e ruotate



6

4 pieghe a valle

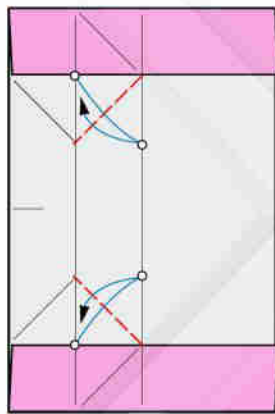

7

2 pieghe a valle

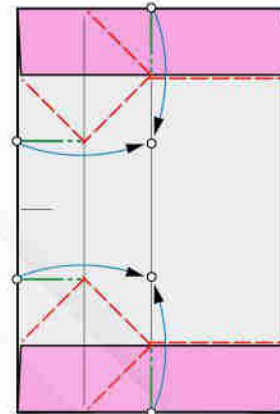

8

2 pieghe a monte e ruotate ripiegando a valle

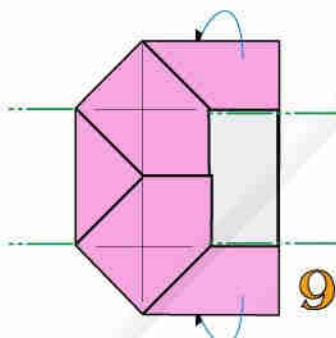

9

4 pieghe a monte e ruotate

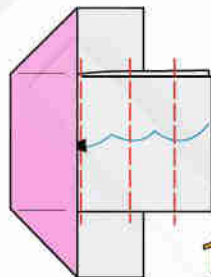

10

3 pieghe a valle in successione e ruotate

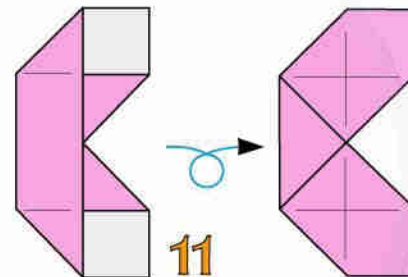

11

Gomito a 90° smussato ultimato

Gomitolo a croce

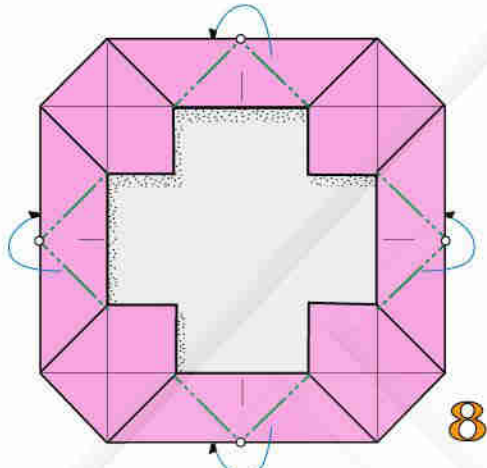

Partite dalla fig. n. 7 di "Piastra".
4 pieghe a monte e ruotate

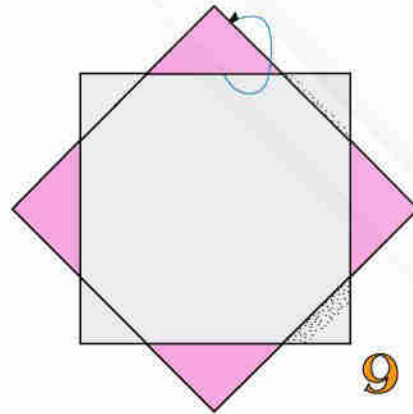

Rovesciate il triangolo indicato

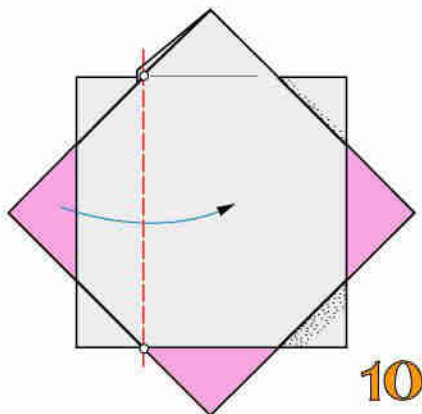

1 piega a valle e ruotate

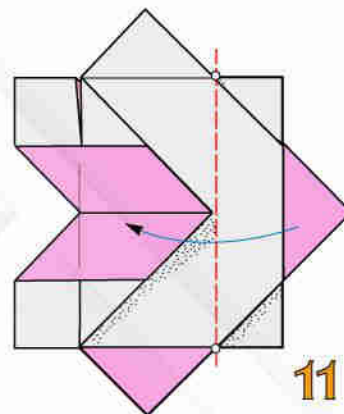

1 piega a valle e ruotate

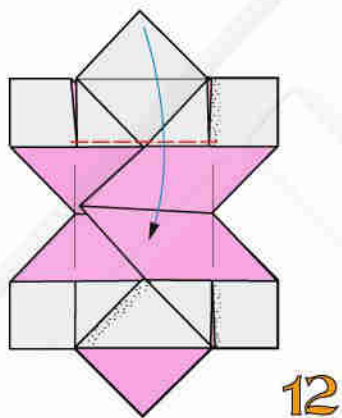

1 piega a valle e ruotate

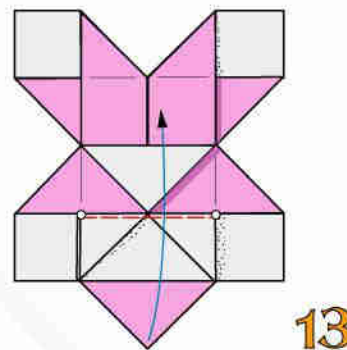

1 piega a valle e ruotate

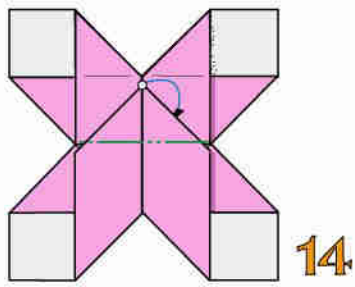

1 piega a monte e
intascate bloccando.

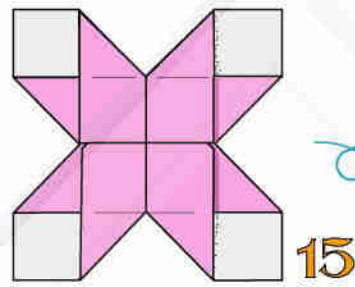

Gomito a croce ultimato

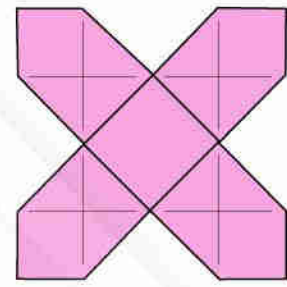

Gomito a T

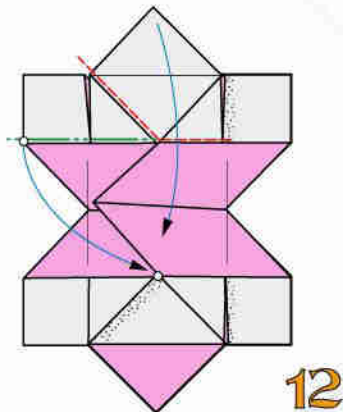

Partite dalla fig. n. 11 di "gomito a croce".
Ruotate ripiegando a valle ed a monte

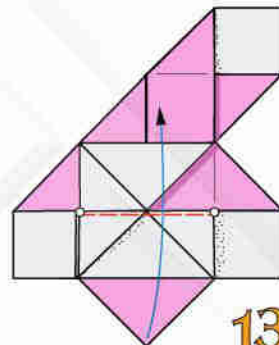

Una piega a valle e ruotate

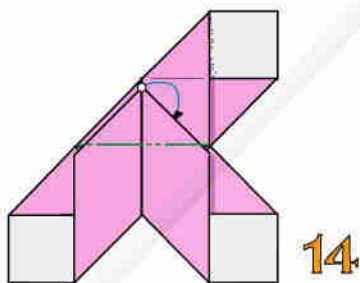

1 piega a monte e
intascate bloccando.

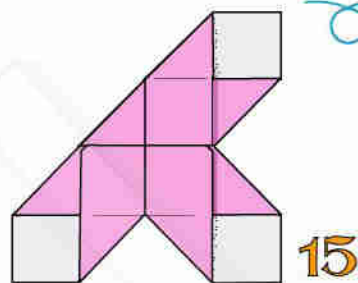

Gomito a T ultimato

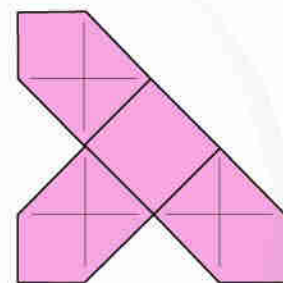

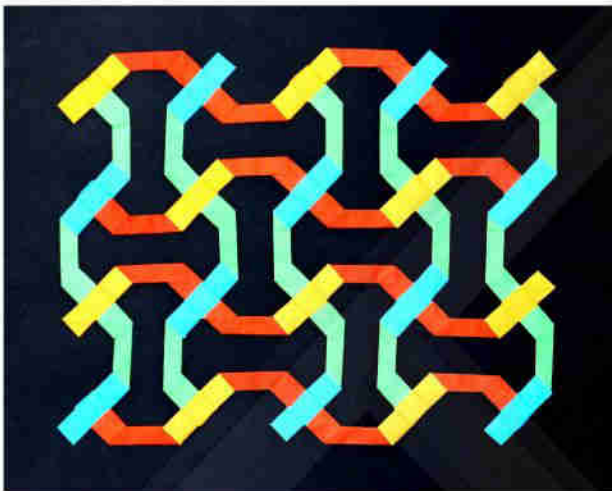

Tassellazione realizzata con moduli:
 Asta a C
 Asta a croce
 Asta a T

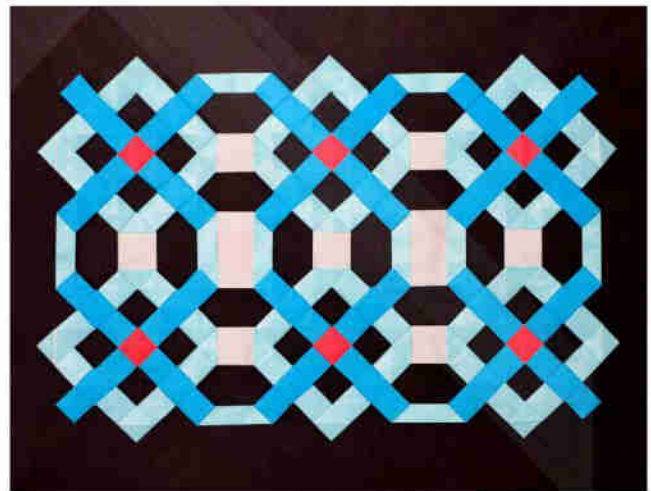

Tassellazione realizzata con moduli:
 Piastra
 Semipiastra
 Asta a croce
 Gomito a 90°

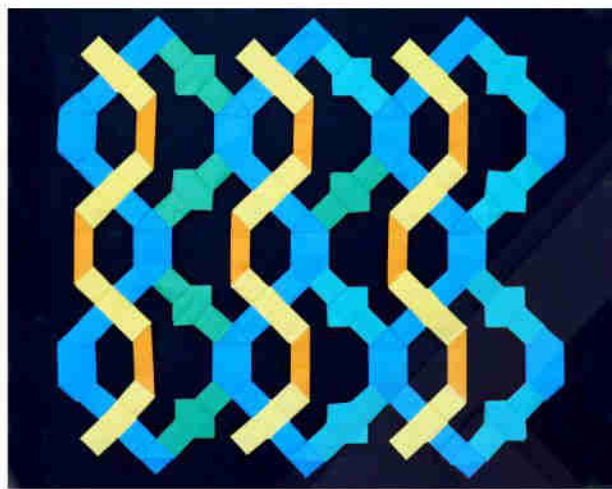

Tassellazione realizzata con moduli:
 Semipiastra
 Asta a croce
 Asta a C
 Asta 3&5
 Gomito a 90°

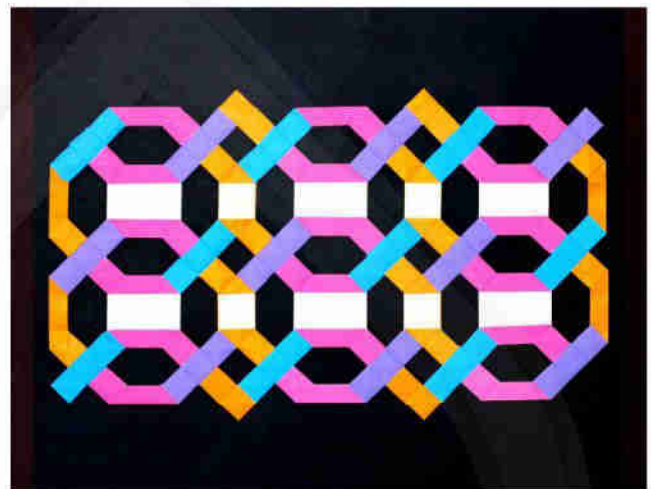

Tassellazione realizzata con moduli:
 Piastra
 Semipiastra
 Asta a croce
 Asta a T
 Asta a C
 Gomito a 90°

ESEMPI DI COSTRUZIONI TRIDIMENSIONALI



Modello realizzato con moduli:
 Piastra (foglio bicolore)
 Semipiastra (foglio bicolore)
 Asta a croce
 Asta a T
 Asta a C
 Gomito 90°



Modello realizzato con moduli:
 Asta a C
 Asta a croce
 Asta a T

ESEMPI DI CATENE



Modello realizzato
 con moduli:
 Gomito 90°



Modello realizzato
 con moduli:
 Gomito 90°
 Asta a C



Modello realizzato
 con moduli:
 Semipiastra
 Asta a C; Gomito 90°



Modello 3D
 realizzato con
 moduli:
 Asta a C
 Gomito a 90°

Gomito 45°

Modulo di difficile costruzione necessario per la realizzazione di progetti complessi di pizzi o gioielli.

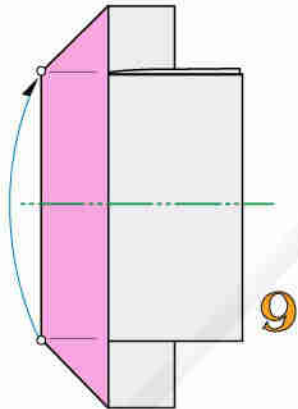

9

Partite dalla fig. n. 8 di "Asta a C".
1 piega a monte e ruotate

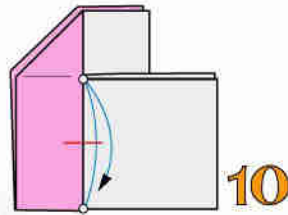

10

1 piccola piega a valle solo sulla sup. in vista

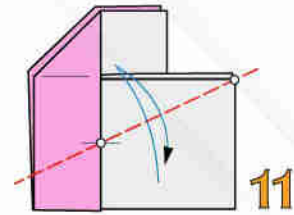

11

1 piega a valle solo sulla sup. in vista

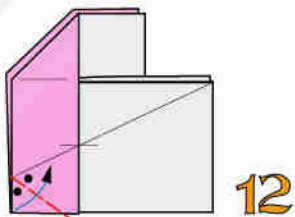

12

1 piega bisettrice a valle e ruotate

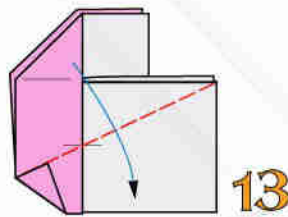

13

Ruotate ripiegando a valle

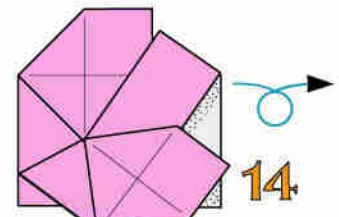

14

Ribaltate

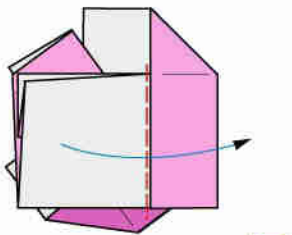

15

1 piega a valle e ruotate

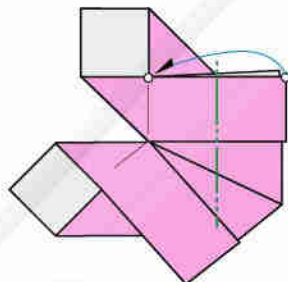

16

1 piega a monte e ruotate

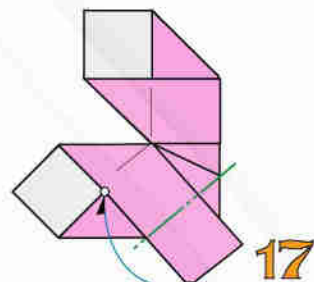

17

1 piega a monte e ruotate

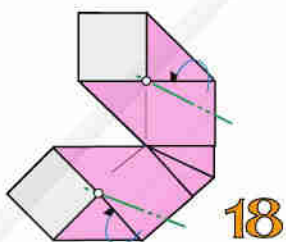

18

2 pieghe a monte e ruotate

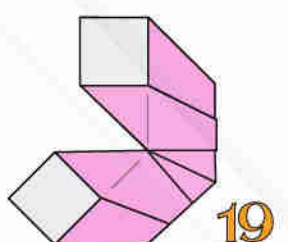

19

Gomito 45° ultimato

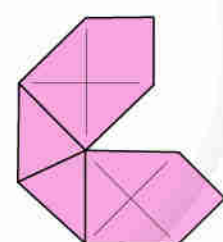

Gomito 135°

Anche questo è un modulo di difficile costruzione utile per la realizzazione di progetti complessi di pizzi o gioielli. Si tratta di un modulo asimmetrico, del quale esistono la versione destra e la sinistra.

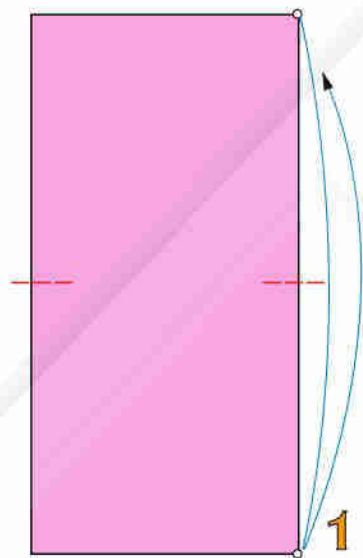

2 piccole pieghe a valle

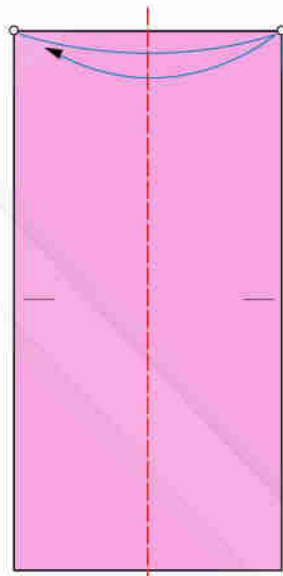

1 piega a valle

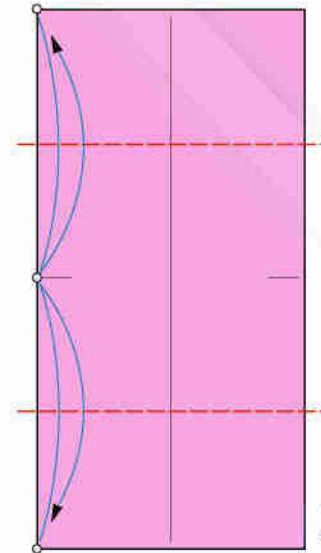

2 pieghe a valle

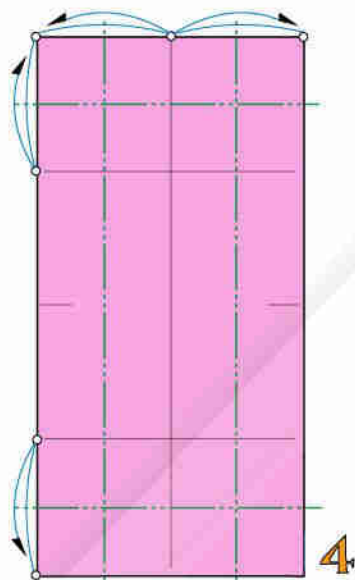

4 pieghe a monte

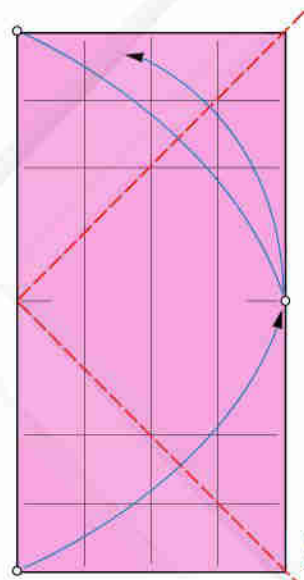

2 pieghe a valle e ruotate il vertice inferiore

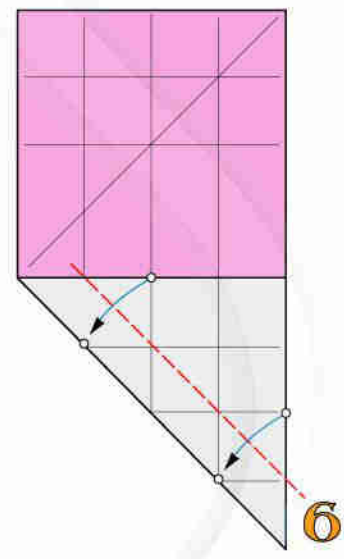

1 piega a valle e ruotate

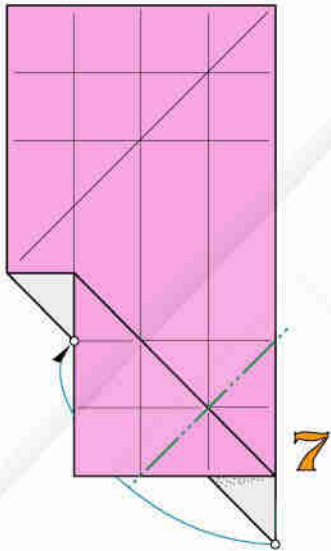

1 piega a monte e ruotate

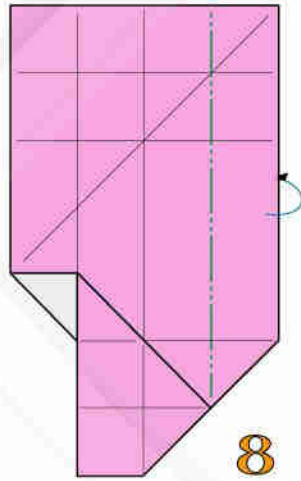

Ripiegando a monte ruotate

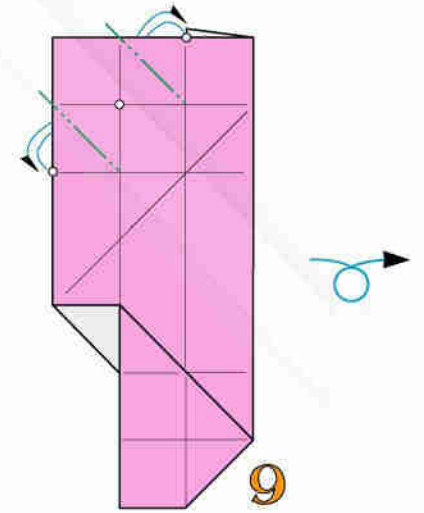

2 pieghe a monte e ribaltate

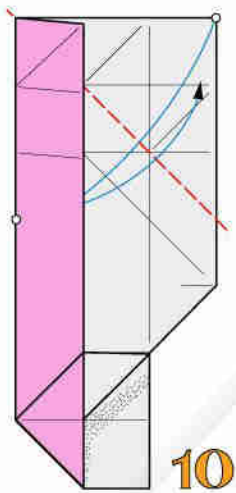

1 piega a valle

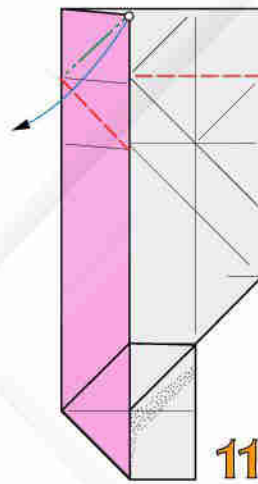

1 piega a valle e ruotate ripiegando a valle ed a monte

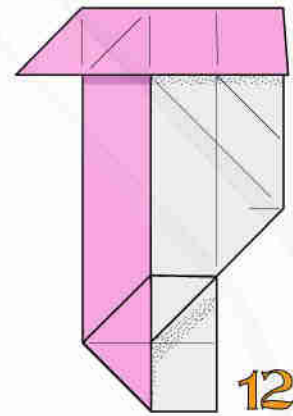

Ribaltate

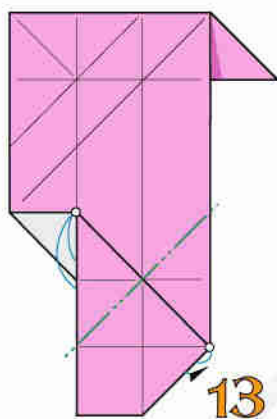

1 piega a monte

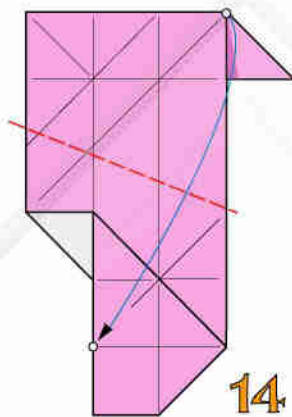

1 piega a valle e ruotate

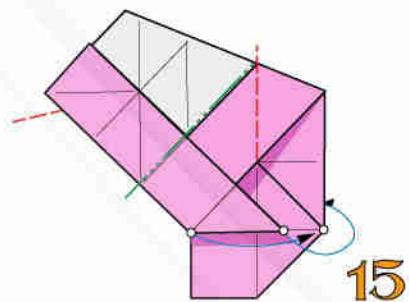

2 pieghe a valle, 1 a monte ed effettuate una rotazione

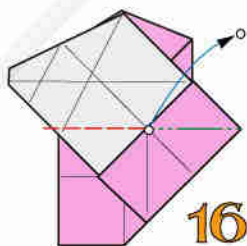

1 piega a valle, 1 a monte ed effettuate una rotazione

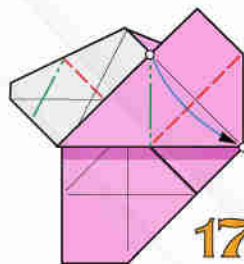

1 piega a valle, ed effettuate una rotazione ripiegando a valle ed a monte

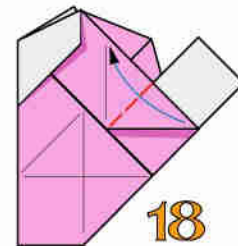

1 piega a valle e ruotate

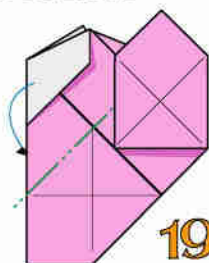

1 piega a monte, ruotate e ribaltate

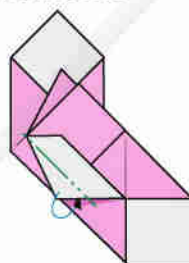

1 piega a monte e ruotate

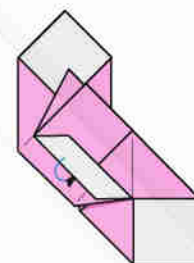

Intascate nel trapezio sottostante

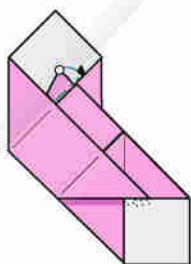

1 piega a valle e ruotate

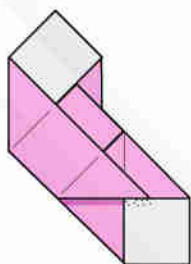

Gomito 135° ultimato

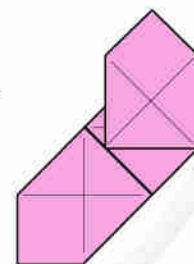

Gomito 180°

Questo è un modulo ricavabile con un procedimento costruttivo insolito ma non difficile, indispensabile in molte occasioni,

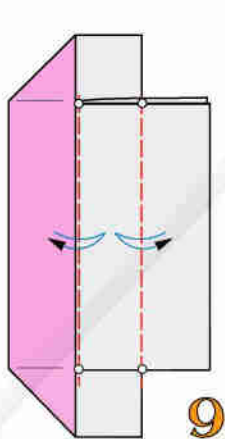

9

Partite dalla fig. n. 8 di "Asta a C".
2 pieghe a valle

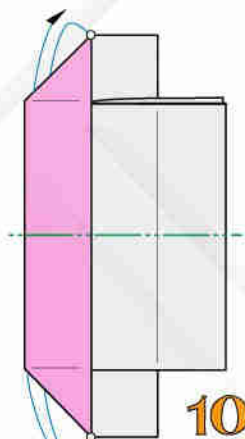

10

Una piega a monte

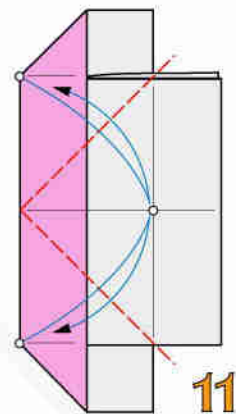

11

2 pieghe a valle

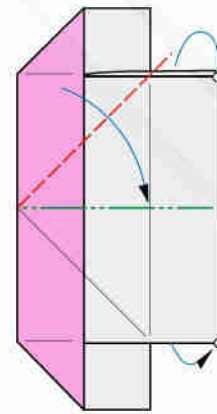

12

Ruotate ripiegando a valle ed a monte

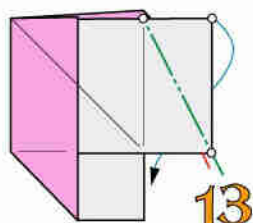

13

Una piega rovescia interna

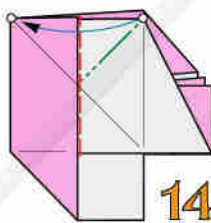

14

Una piega a valle, una a monte e ruotate

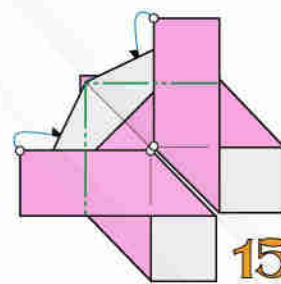

15

Due pieghe a monte e ruotate all'interno

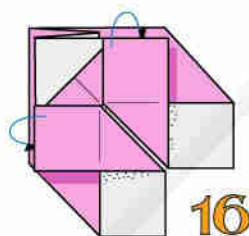

16

Inserite i 2 bordi indicati all'interno delle 2 tasche trapezoidali sottostanti

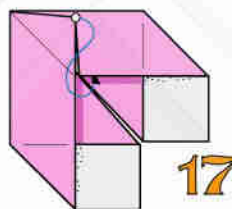

17

Inserite il vertice indicato all'interno della tasca sottostante

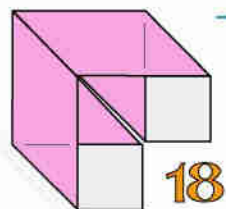

18

Gomito 180° ultimato

A B C D E F G H I L M N O
P Q R S T U V Z Y X W J
1 2 3 4 5 6 7 8 9 0

Per la realizzazione di lettere e numeri adoperate foglietti monocolori di differenti colori.
 Per la realizzazione di originali cornici, nastri e pizzi sono consigliabili sormonti ed intrecci

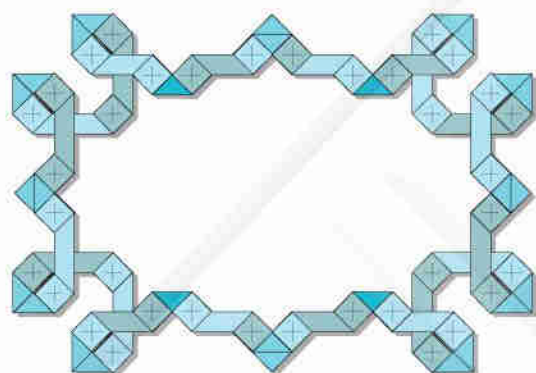

Cornice realizzata con aste C,S e gomiti 90°, 180°

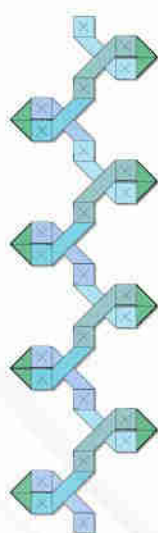

Pizzo realizzato con aste C e gomiti a 180°

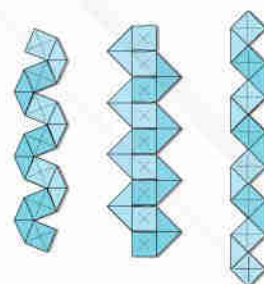

Nastri realizzati con gomiti 45°, 180°, 90°

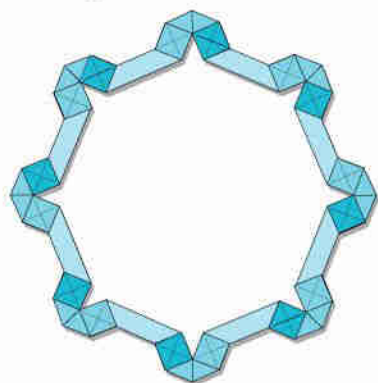

Cornice realizzata con aste C e gomiti 45°

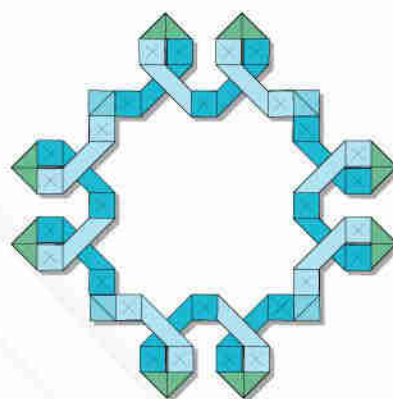

Cornice realizzata con aste C e gomiti 90°, 180°

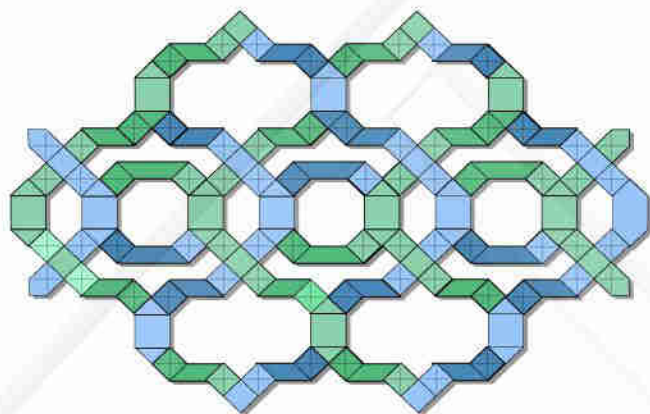

Pizzo realizzato con semipiastre, aste S, gomiti a croce e 90°

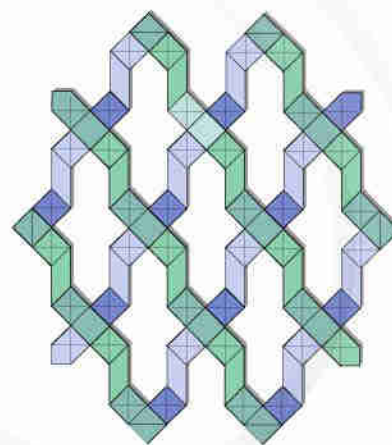

Pizzo realizzato con aste S, gomiti a croce e 90°

Ciondoli Orecchini Spille

Meccanorigami è il sistema costruttivo ideale per la costruzione di gioielli origami.

Dopo aver montato il gioiello con foglietti di stagnola o carta metallizzata, con modellazione piatta o bombata, si fissa con colla istantanea una spilletta dotata di una piattina.

Successivamente lo si immerge 2-3 volte in liquido cristallizzante bicomponente che lo rende indistruttibile.

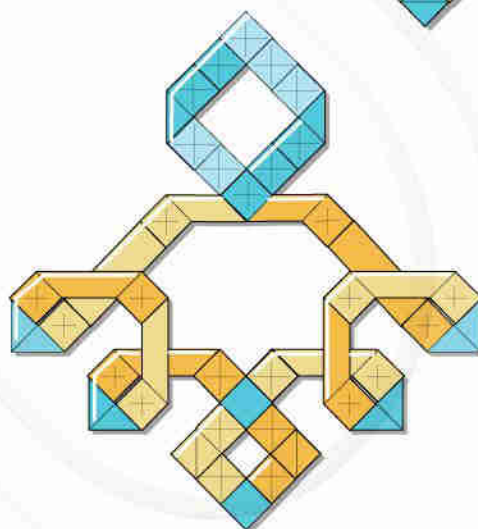
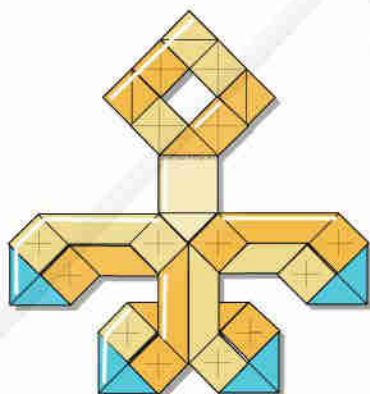
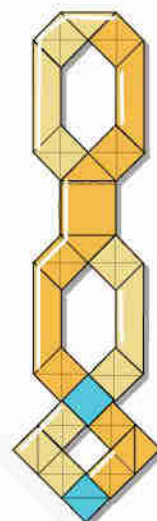
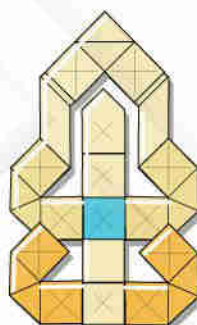
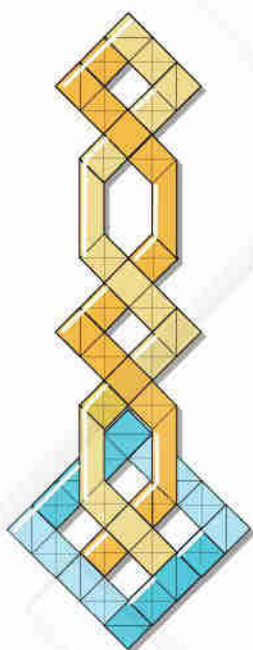
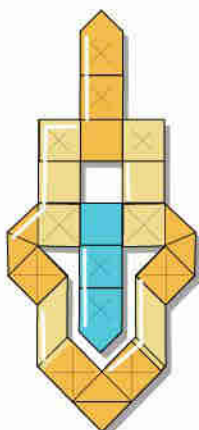
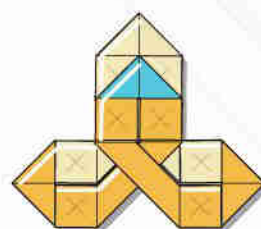
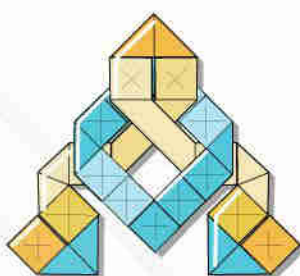
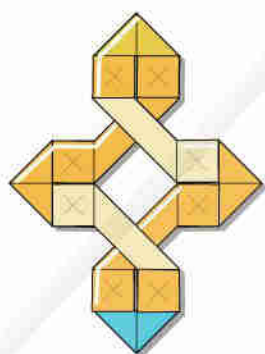

PUBBLICAZIONI DI FRANCO PAVARIN

Aerei , jet ed astronavi di carta volanti	IL CASTELLO	1986
Origami animati	“	1987
Origami maschere animate	”	1988
Decorazioni modulari con origami modulati	“	1989
Origami motoscafi navi barche e velieri	”	1990
Origami scatole e contenitori	“	1990
Pieghe forme e colori	”	1994
Aerei e navi di carta	FABBRI	1996
Fold and fly Paper airplanes	STERLING PUBLISHING	1998
Manuale rapido di aerei di carta volanti	FABBRI	2000
Aerei di carta 17 modelli volanti inediti	IL CASTELLO	2001
Aviones voladores	TUTOR S.A.	2003
17 modelos ineditos de aviones voladores	“	2004
Naves voladoras	”	2006
Quaderni Quadrato magico n.20 e 48	CDO	
Maschere, elmi e copricapi	web	2010
Maschere trasformabili	web	2011
21 nuovi aerei origami volanti	web	2014
Maschere origami 3D volume 1	web	2014
Maschere origami 3D volume 2	web	2015
Legorigami 1 -Q.Quadrato Magico n.56		2015

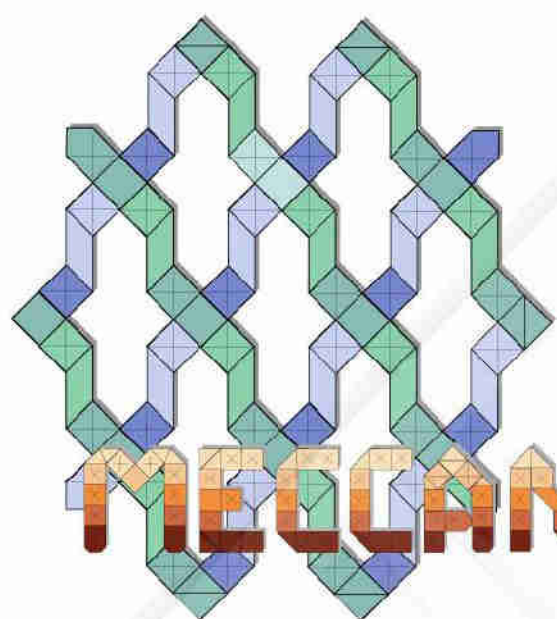

MEGACANORIGAMI

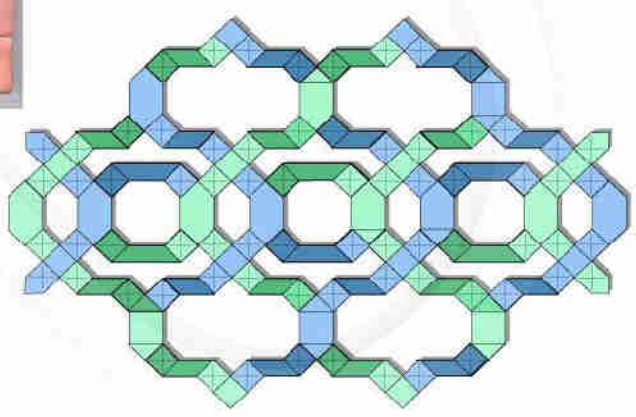

Franco Pavarin

www.aereiemaschereorigami.altervista.org