

● OSA TOLA

● Creador y diagramas: *Marc Vigo*

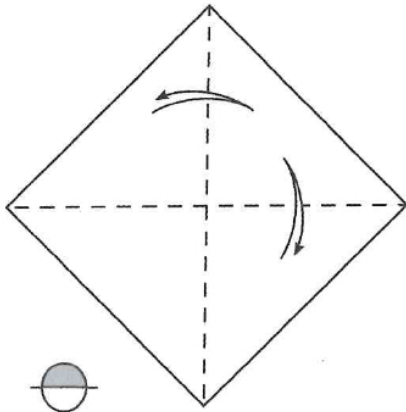

1. Valley fold/unfold two diagonals.

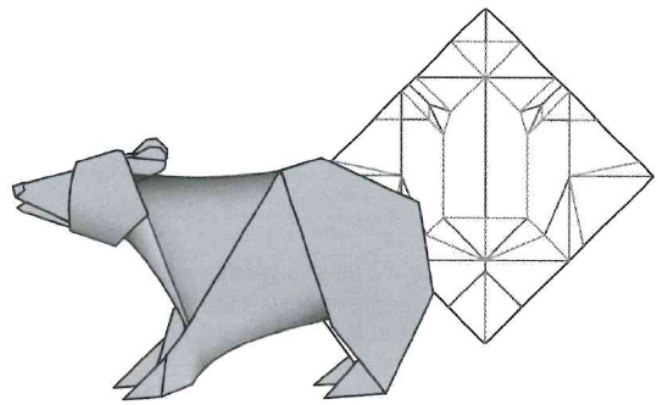
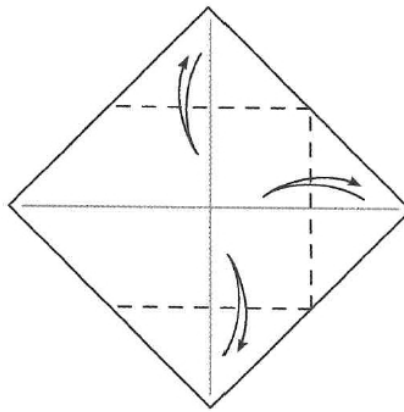

2. Blintz fold/unfold three points to the center.

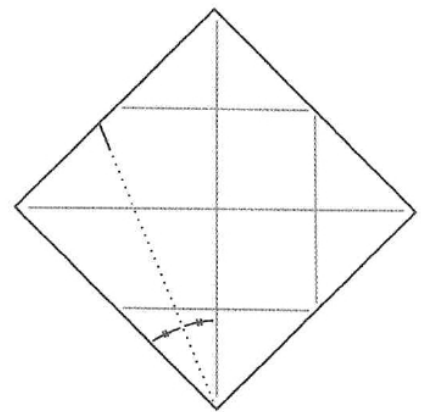

3. Pinch using a bisector.

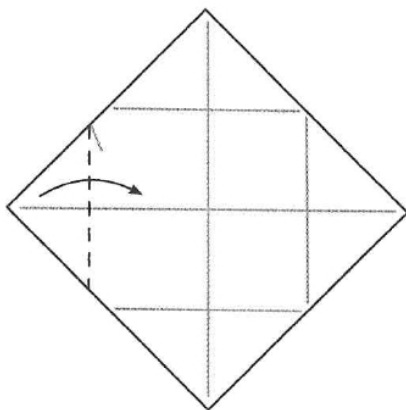

4. Valley fold through the pinch.

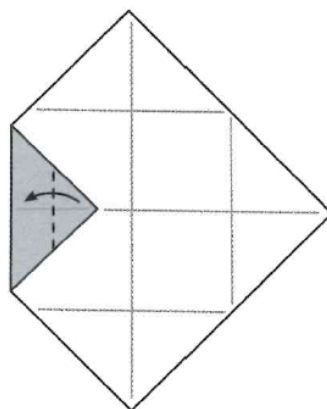

5. Fold triangle in half.

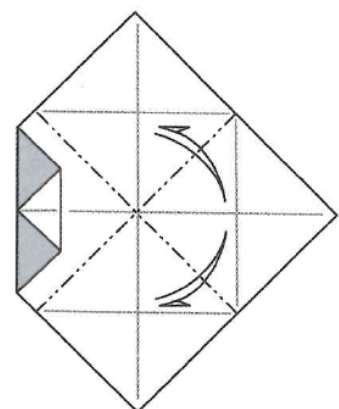

6. Mountain fold/unfold paper in halves.

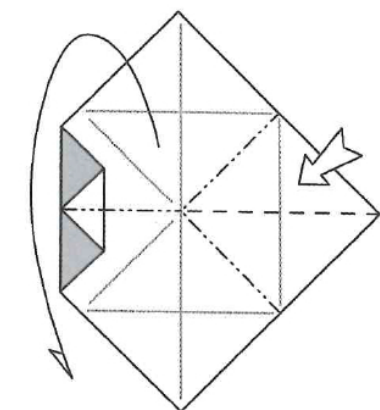

7. Collapse with a rabbit ear.

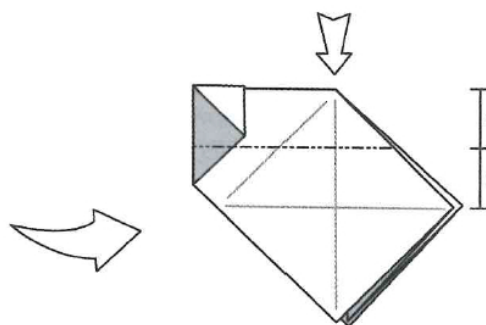

8. Open sink.

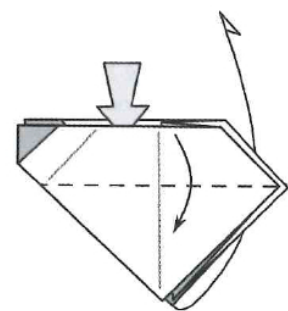

9. Open and squash. Raise flap on the back.

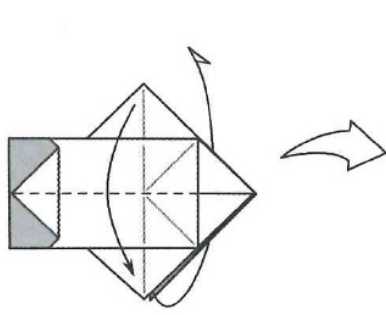

10. Valley fold in half and raise lower point.

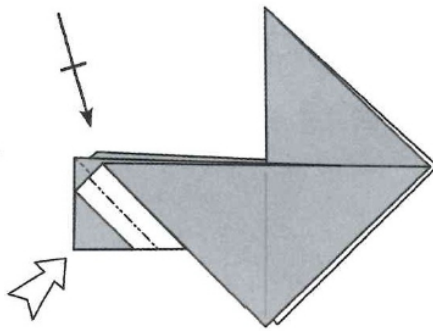

11. Reverse fold. Repeat behind.

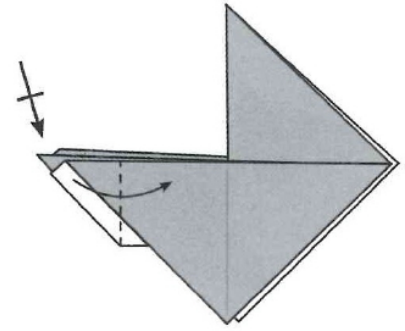

12. Book fold to the left. Repeat behind.

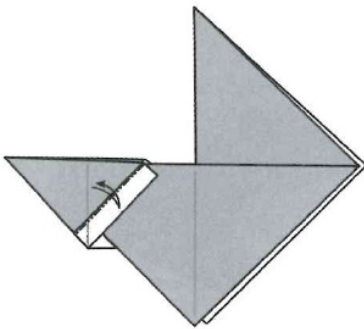

13. Mountain fold/unfold along color change.

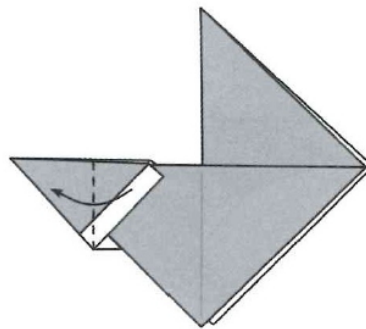

14. Book fold back to the right.

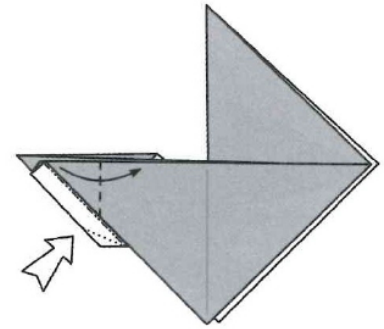

15. Open sink the white part using previous creases and book fold to the left.

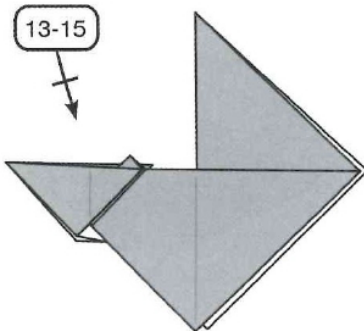

16. Repeat steps 13-15 on the back.

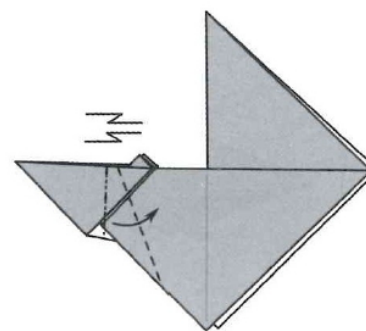

17. Crimp. No references. The angles are critical for a nice looking head.

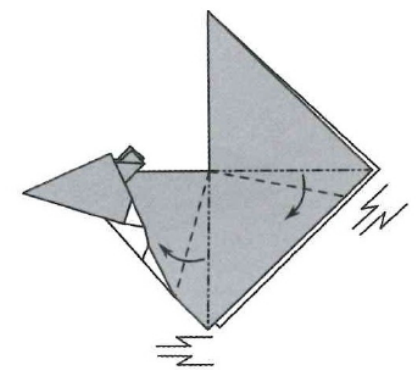

18. Crimp to form fore and back legs.

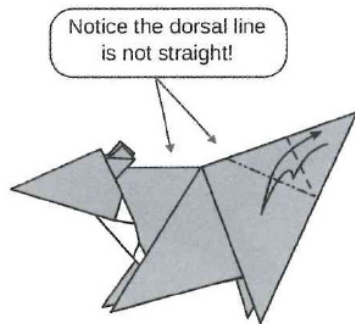

19. Pre-pleat at the back, then unfold.

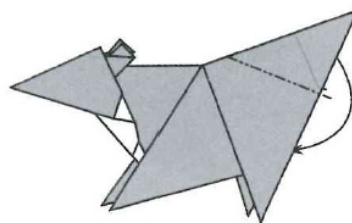

20. Reverse fold inside.

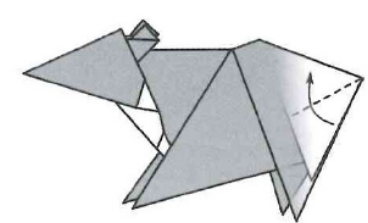

21. Valley fold inside flap to lock the butt.

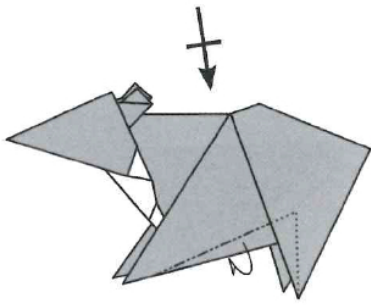

22. Swivel fold on the belly.

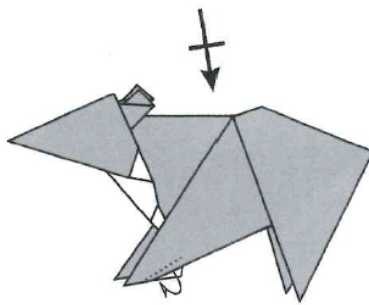

23. Valley fold to hide this small part.

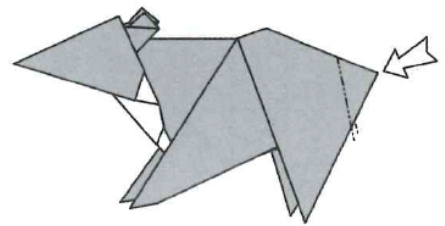

24. Reverse fold.

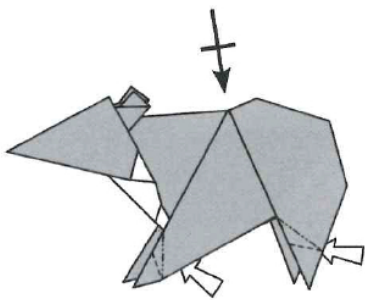

25. Crimp fore and back legs.

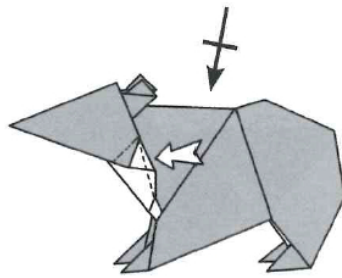

26. Swivel fold.

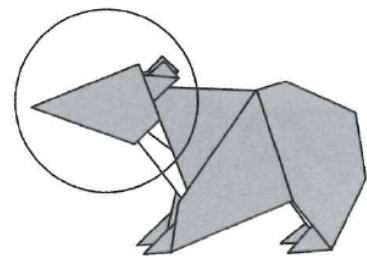

27. Focus on the head.

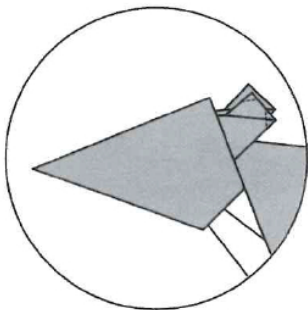

28. Round the ears.

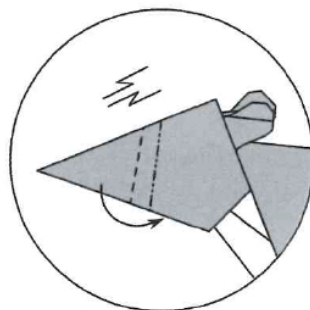

29. Crimp to form the nozzle.

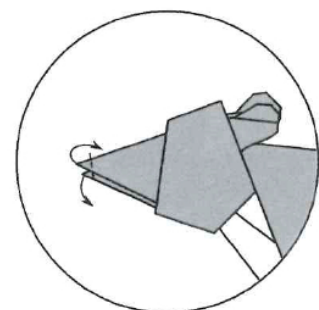

30. Outside reverse fold the tip of the nozzle. Open the lower jaw.

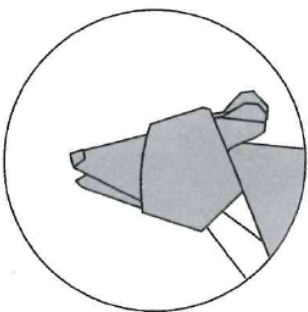

31. Model the head at your taste.

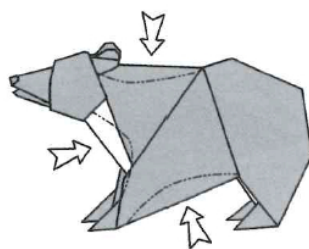

32. Give some volume to the body with curved folds.

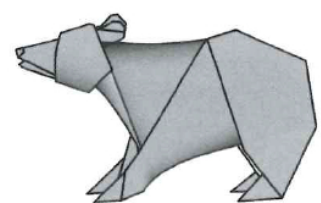

33. Finished bear.