

26

Collapse as shown.

30

Squash and form a petal fold.

35

Repeat steps 26 to 34.

25

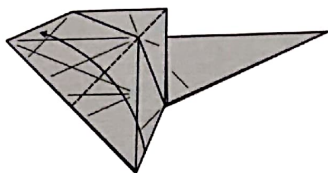

26

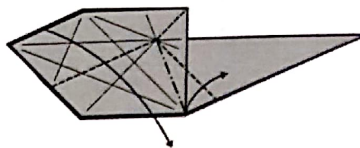

27

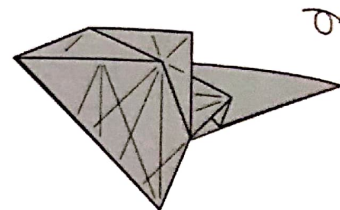

28

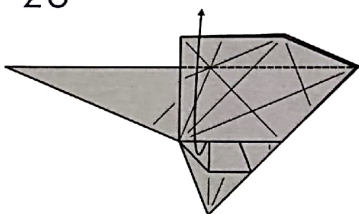

29

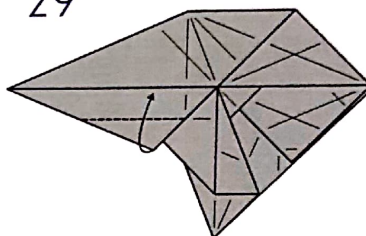

30

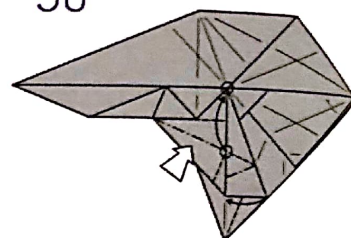

31

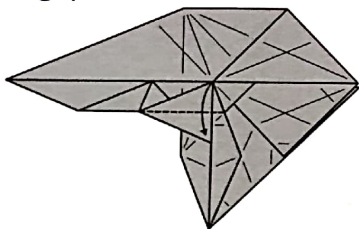

32

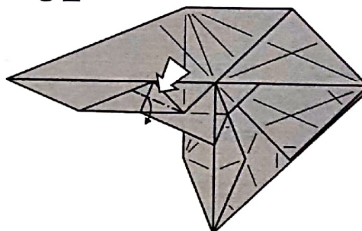

33

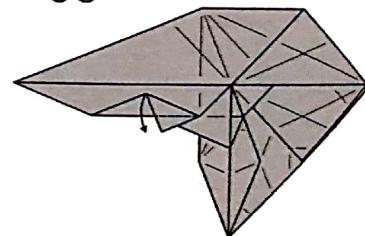

34

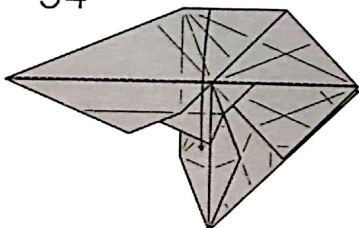

35

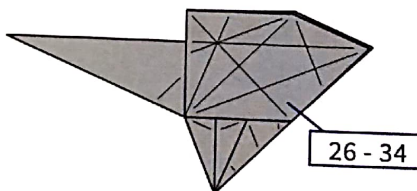

36

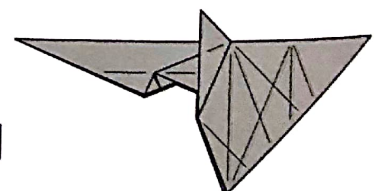

37
Fold and unfold.
Use reference
point.

38
Pleat inside.

41
Fold out the
corner of the
flap.

42
Inside reverse
fold.

43
Inside reverse
fold.

44
Inside reverse
fold.

45
Valley fold.

46
Mountain fold.
Repeat behind.

47
Crimp.

48
Mountain fold
inside. Repeat
behind.

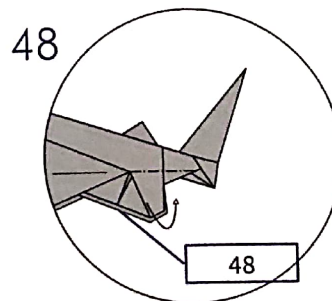
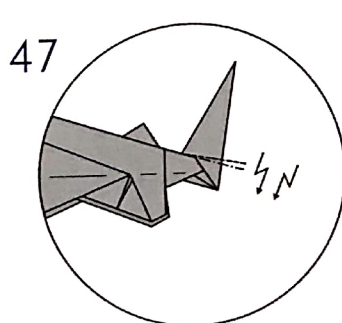
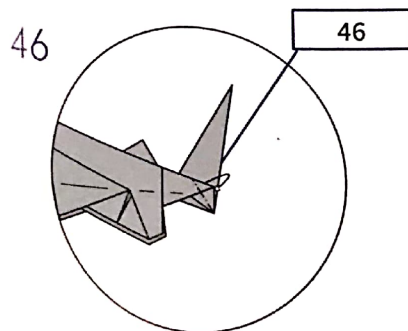
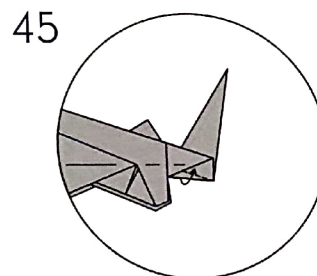
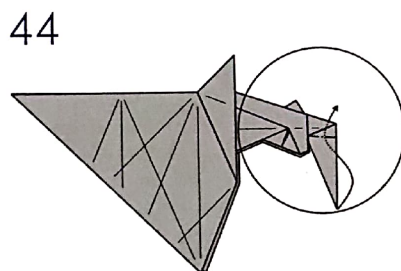
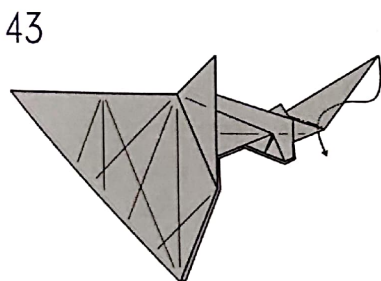
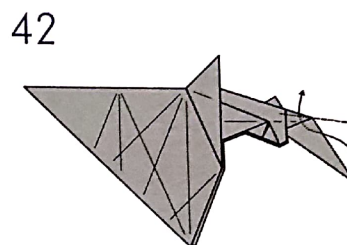
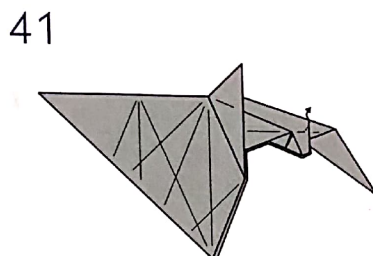
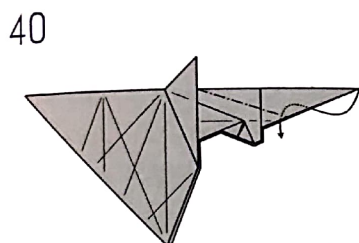
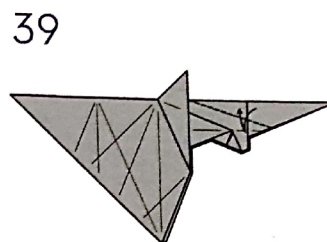
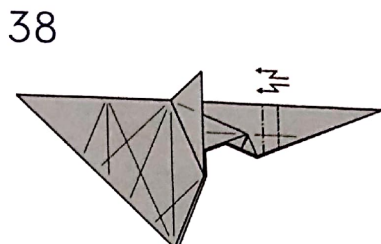
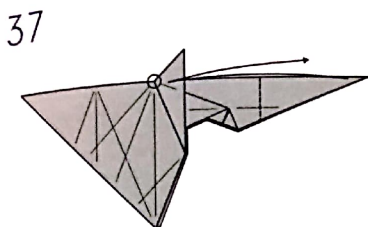

73

Crimp.

74

Crimp.

75

Fold the fin up
at an angle.
Repeat behind.

76

Fold and unfold.

77

Inside reverse
fold.

78

Valley fold the
flap inside.

79

Inside reverse
fold.

80

Shape.

81

Bull shark
completed.

